

13

Differential Calculus I: Fundamentals

Assessment statements

6.1 Informal ideas of limit, continuity and convergence.

Definition of derivative from first principles: $f'(x) = \lim_{h \rightarrow 0} \frac{f(x+h) - f(x)}{h}$.

Derivative interpreted as gradient function and as rate of change.

Find equations of tangents and normals.

Identifying increasing and decreasing functions.

The second derivative.

6.2 Derivative of x^n .

6.3 Local maximum and minimum points.

Points of inflexion with zero and non-zero gradients.

Graphical behaviour of functions including the relationship between the graphs of f , f' and f'' .

6.6 Kinematic problems involving displacement, s , velocity, v , and acceleration, a .
(See also Chapter 15.)

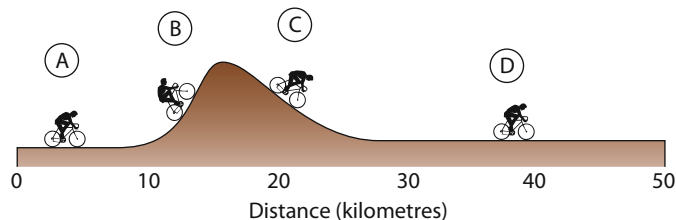
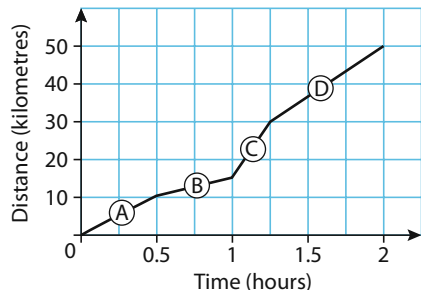

Introduction

Calculus is the branch of mathematics that was developed to analyze and model change – such as velocity and acceleration. We can also apply it to study change in the context of slope, area, volume and a wide range of other real-life phenomena. Although mathematical techniques that you have studied previously deal with many of these concepts, the ability to model change was restricted. For example, consider the curve in Figure 13.1. This shows the motion of an object by indicating the distance (y metres) travelled after a certain amount of time (t seconds). Pre-calculus mathematics will only allow us to compute the **average velocity** between two different times (Figure 13.2). With calculus – specifically, techniques of differential calculus – we will be able to find the velocity of the object at a particular instant, known as its **instantaneous velocity** (Figure 13.3). The starting point for our study of calculus is the idea of a limit.

A bicycle ride over a hill: The graph above left shows distance (km) versus time (hrs) for a 50-kilometre bicycle ride that included going up and then down a steep hill. There are four time intervals labelled A, B, C and D. During which interval is the bicyclist's speed the least? the greatest? During which two intervals is the bicyclist's speed about the same? How does the shape of the distance-time graph give information about the speed of the bicyclist during a certain interval? or at a particular moment (instant) during the ride?

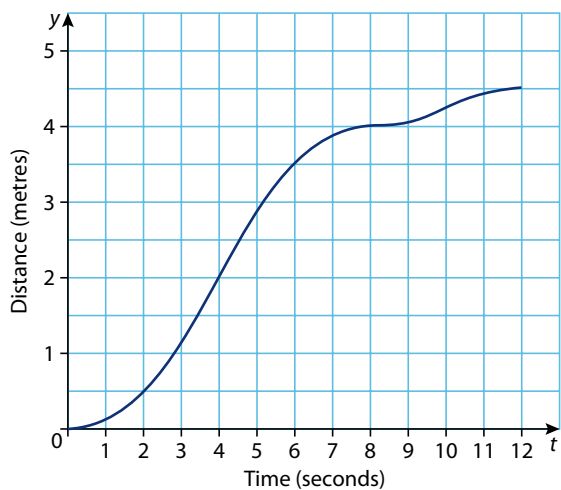

Figure 13.1 Distance–time graph for an object’s motion.

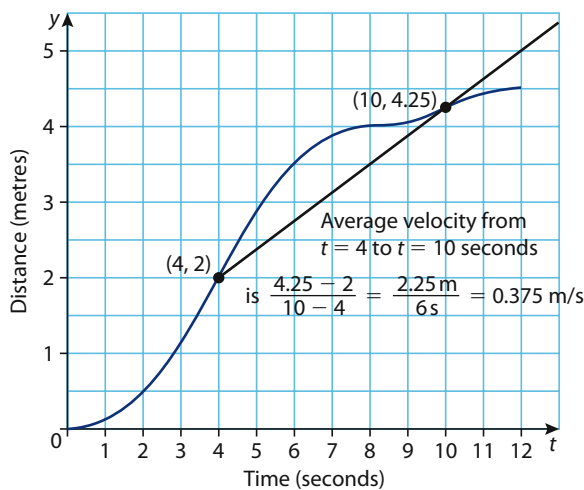

Figure 13.2 Computing average velocity from a distance–time graph.

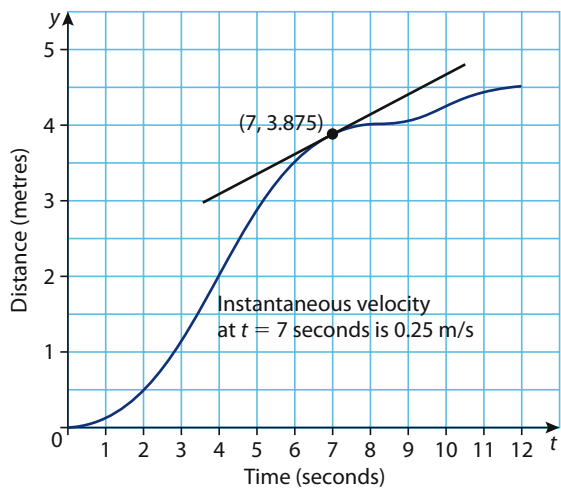

Figure 13.3 Instantaneous velocity from a distance–time graph.

13.1 Limits of functions

A **limit** is one of the ideas that distinguish calculus from algebra, geometry and trigonometry. The notion of a limit is a fundamental concept of calculus. Limits are not new to us. We often use the idea of a ‘limit’ in many non-mathematical situations. Mathematically speaking, we have encountered limits on at least two occasions previously in this book – finding the sum of an infinite geometric series (Section 4.4) and computing the irrational number e (Section 5.3).

Recall from Section 4.4 that we established that if the sequence of partial sums for an infinite series **converges** to a finite number L we say that the infinite series has a ‘sum’ of L . Further on in that section, we used limits to algebraically confirm that the infinite series $2 + 1 + \frac{1}{2} + \frac{1}{4} + \frac{1}{8} + \dots$ has a sum of 4. As part of the algebra for this, we reasoned that as the value of n increases in the positive direction without bound (i.e. $n \rightarrow +\infty$) the expression $\left(\frac{1}{2}\right)^n$ converges to zero – in other words, the **limit** of $\left(\frac{1}{2}\right)^n$ as n goes to positive infinity is zero. We express this result more efficiently using limit notation, as we did in Chapter 4, by writing $\lim_{n \rightarrow \infty} \left(\frac{1}{2}\right)^n = 0$.

It is beyond the requirements of this course to establish a precise formal definition of a limit, but a closer look at justifying this limit and a couple of others can lead us to a useful informal definition.

Example 1

Evaluate $\lim_{n \rightarrow \infty} \left(\frac{1}{2}\right)^n$ by using your GDC to analyze the behaviour of the function $f(x) = \left(\frac{1}{2}\right)^x$ for large positive values of x .

Solution

```
Plot1 Plot2 Plot3
\Y1=(1/2)^X
\Y2=
\Y3=
\Y4=
\Y5=
\Y6=
\Y7=
```

```
WINDOW
Xmin=-1
Xmax=8
Xscl=1
Ymin=.1
Ymax=1
Yscl=1
Xres=1
```

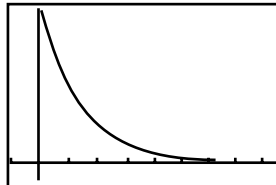

```
TABLE SETUP
TblStart=0
ΔTbl=1
Indpnt: Auto Ask
Depend: Auto Ask
```

X	Y1
0	1
1	.5
2	.25
3	.125
4	.0625
5	.03125
6	.01563

X=0

X	Y1
7	.00781
8	.00391
9	.00195
10	9.8E-4
11	4.9E-4
12	2.4E-4
13	1.2E-4

Y1=1.22070313E-4

The GDC screen images show the graph and table of values for $y = \left(\frac{1}{2}\right)^x$.

Clearly, the larger the value of x , the closer that y gets to zero. Although there is no value of x that will produce a value of y equal to zero, we can get as close to zero as we wish. For example, if we wish to produce a value of y within 0.001 of zero, then we could choose $x = 10$ and $y = \left(\frac{1}{2}\right)^{10} = \frac{1}{1024} \approx 0.00097656$; and if we want a result within 0.000001 of zero, then we could choose $x = 24$ and $y = \left(\frac{1}{2}\right)^{24} = \frac{1}{16777216} \approx 0.00000059605$; and so on. Therefore, we can conclude that $\lim_{n \rightarrow \infty} \left(\frac{1}{2}\right)^n = 0$.

In calculus we are interested in limits of functions of real numbers. Although many of the limits of functions that we will encounter can only be approached and not actually reached (as in Example 1), this is not always the case. For example, if asked to evaluate the limit of the function $f(x) = \frac{x}{2} - 1$ as x approaches 6, we simply need to evaluate the function for $x = 6$. Since $f(6) = 2$, then $\lim_{x \rightarrow 6} \left(\frac{x}{2} - 1\right) = 2$.

However, it is more common that we are unable to evaluate the limit of $f(x)$ as x approaches some number c because $f(c)$ does not exist.

Example 2

Find the following two limits using your GDC to analyze the behaviour of the relevant function.

a) $\lim_{x \rightarrow 0} \frac{\sin x}{x}$

b) $\lim_{x \rightarrow 0} \frac{\cos x - 1}{x}$



The line $y = c$ is a **horizontal asymptote** of the graph of a function $y = f(x)$ if either $\lim_{x \rightarrow \infty} f(x) = c$ or $\lim_{x \rightarrow -\infty} f(x) = c$. For example, the line $y = 0$ (x -axis) is a horizontal asymptote of the graph of $y = \left(\frac{1}{2}\right)^x$ because $\lim_{x \rightarrow \infty} \left(\frac{1}{2}\right)^x = 0$.

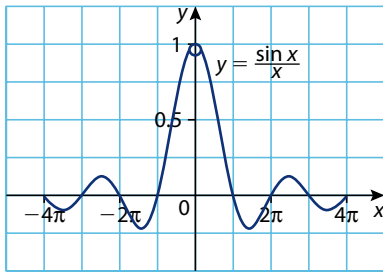

```
Plot1 Plot2 Plot3
\Y1= sin(X)/X
\Y2=
\Y3=
\Y4=
\Y5=
\Y6=
\Y7=
```

```
Y1 (-.05)
.9995833854
Y1 (.05)
.9995833854
1-Ans
4.166145864E-4
```

```
Y1 (-.002)
.9999993333
Y1 (.002)
.9999993333
1-Ans
6.66666655E-7
```

```
Plot1 Plot2 Plot3
\Y1= (cos(X)-1)/X
\Y2=
\Y3=
\Y4=
\Y5=
\Y6=
```

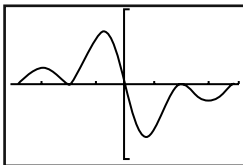

X	Y1
-.03	.015
-.02	.01
-.01	.005
0	ERROR
.01	-.005
.02	-.01
.03	-.015

X=-.03

Solution

- a) We are not able to evaluate this limit by direct substitution because when $x = 0$, $\frac{\sin x}{x} = \frac{0}{0}$ and is therefore undefined. Let's use our GDC again to analyze the behaviour of the function $f(x) = \frac{\sin x}{x}$ as x approaches zero from the right side and the left side.

Although there is no point on the graph of $y = \frac{\sin x}{x}$ corresponding to $x = 0$, it is clear from the graph that as x approaches zero (from either direction) the value of $\frac{\sin x}{x}$ converges to one. We can get the value of $\frac{\sin x}{x}$ arbitrarily close to 1 depending on our choice of x .

If we want $\frac{\sin x}{x}$ to be within 0.001 of 1, we choose $x = 0.05$ giving $\frac{\sin 0.05}{0.05} \approx 0.999583$ and $1 - 0.999583 = 0.000417 < 0.001$; and if

we want $\frac{\sin x}{x}$ to be within 0.000001 of 1, then we choose $x = 0.002$ giving $\frac{\sin 0.002}{0.002} \approx 0.999993333$ and $1 - 0.999993333$

$= 0.000006667 < 0.000001$; and so on.

Therefore, $\lim_{x \rightarrow 0} \frac{\sin x}{x} = 1$.

- b) As with $y = \frac{\sin x}{x}$, substituting $x = 0$ into the function $y = \frac{\cos x - 1}{x}$ produces the meaningless fraction $\frac{0}{0}$. The graph of $y = \frac{\cos x - 1}{x}$ (GDC images right) reveals that the function values approach 0 as x goes to 0. A table produced on a GDC also shows that the function values approach zero from both directions.

Therefore, $\lim_{x \rightarrow 0} \frac{\cos x - 1}{x} = 0$.

These two limits are confirmed analytically in the next section.



The analysis and result for Example 2 illustrates why it is preferred (and often necessary) that in calculus the argument of a trigonometric function be in radian measure rather than degrees. The limit of $\frac{\sin x}{x}$ as x goes to ∞ is not equal to 1 if x is in degrees. With your GDC in radian mode, duplicate the graph of $y = \frac{\sin x}{x}$ shown in the solution for Example 2. Now change the window dimensions on your GDC to $X_{\min} = -720$ and $X_{\max} = 720$ (equivalent to -4π and 4π) and graph $y = \frac{\sin x}{x}$ in degree mode. Explain why no graph appears.

i It is interesting to note that if you ask your GDC to evaluate the function $y = \frac{\sin x}{x}$ for a sufficiently small value of x it will give a result of exactly 1. The function is undefined for $x = 0$ and can never give a result of exactly 1, so obviously the calculator is making an error. Due to memory restrictions the calculator has rounded off the result to 1. The GDC image below shows that for $x = 0.00001$ the result has been rounded to 1 when the actual value is $0.99999999998\bar{3}$ (digit 3 repeating). Even the Google calculator (see image below) gives an incorrect result.

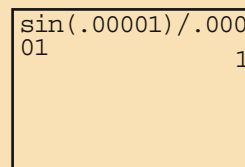
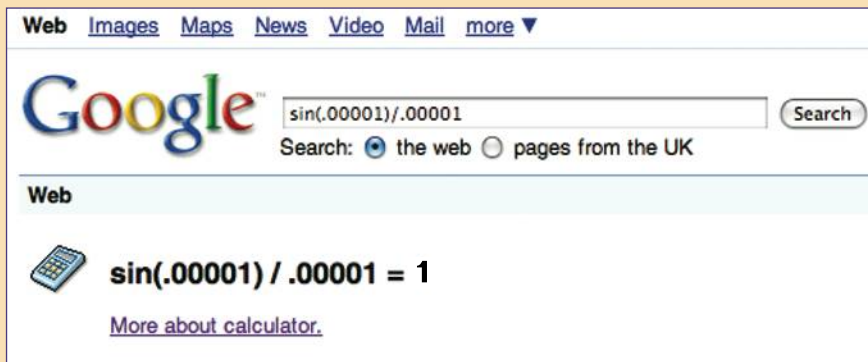

Functions do not necessarily converge to a finite value at every point – it's possible for a limit not to exist.

Example 3

Find $\lim_{x \rightarrow 0} \frac{1}{x^2}$, if it exists.

Solution

As x approaches zero, the value of $\frac{1}{x^2}$ becomes increasingly large in the positive direction. The graph of the function (left) seems to indicate that we can make the values of $y = \frac{1}{x^2}$ arbitrarily large by choosing x close enough to zero. Therefore, the values of $y = \frac{1}{x^2}$ do not approach a finite number, so $\lim_{x \rightarrow 0} \frac{1}{x^2}$ does not exist.

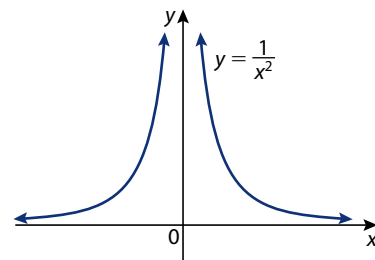

Although we can describe the behaviour of the function $y = \frac{1}{x^2}$ by writing $\lim_{x \rightarrow 0} \frac{1}{x^2} = \infty$, this does not mean that we consider ∞ to represent a number – it does not. This notation is simply a convenient way to indicate in what manner the limit does not exist.

Limit of a function

If $f(x)$ becomes arbitrarily close to a unique finite number L as x approaches c from either side, then the **limit** of $f(x)$ as x approaches c is L . The notation for indicating this is $\lim_{x \rightarrow c} f(x) = L$.

When a function $f(x)$ becomes *arbitrarily close* to a finite number L , we say that $f(x)$ **converges** to L .

i The line $x = c$ is a **vertical asymptote** of the graph of a function $y = f(x)$ if either $\lim_{x \rightarrow c} f(x) = \infty$ or $\lim_{x \rightarrow c} f(x) = -\infty$. For example, the line $x = 0$ (y -axis) is a vertical asymptote of the graph of $y = \frac{1}{x^2}$ because $\lim_{x \rightarrow 0} \frac{1}{x^2} = \infty$.

Often when trying to determine the limit of a quotient by direct substitution, we may get a meaningless fraction such as $\frac{0}{0}$ or $\frac{\infty}{\infty}$. Such an expression is called an **indeterminate form** because we cannot use it to determine the desired limit. When confronted with an indeterminate form we need to perform some algebraic manipulation to the quotient to get it into a form so that the limit can be evaluated by direct substitution and/or applying known limits.



For our purposes in this course, it is also important to be able to apply some basic algebraic manipulation in order to evaluate the limits of some functions algebraically, rather than by conjecturing from a graph or table.

The following five properties of limits are also useful.

Properties of limits

Let a and b be real numbers, and let f and g be functions with the following limits.

$$\lim_{x \rightarrow a} f(x) = L \text{ and } \lim_{x \rightarrow a} g(x) = K$$

- 1 Constant: $\lim_{x \rightarrow a} b = b$
- 2 Scalar multiple: $\lim_{x \rightarrow a} [b \cdot f(x)] = b \cdot L$
- 3 Sum or difference: $\lim_{x \rightarrow a} [f(x) \pm g(x)] = L \pm K$
- 4 Product: $\lim_{x \rightarrow a} [f(x) \cdot g(x)] = L \cdot K$
- 5 Quotient: $\lim_{x \rightarrow a} \left[\frac{f(x)}{g(x)} \right] = \frac{L}{K} \quad K \neq 0$

Example 4

Evaluate each limit algebraically.

a) $\lim_{x \rightarrow \infty} \frac{5x - 3}{x}$

b) $\lim_{p \rightarrow 0} (3x^2 - 4px + p^2)$

c) $\lim_{h \rightarrow 0} \frac{[(x + h)^2 - 6] - (x^2 - 6)}{h}$

d) $\lim_{x \rightarrow \infty} \frac{3x^2 + 5x - 1}{2x^2 + 1}$

Solution

$$\begin{aligned} \text{a) } \lim_{x \rightarrow \infty} \frac{5x - 3}{x} &= \lim_{x \rightarrow \infty} \left(\frac{5x}{x} - \frac{3}{x} \right) \\ &= \lim_{x \rightarrow \infty} 5 - \lim_{x \rightarrow \infty} \frac{3}{x} \\ &= 5 - 0 = 5 \end{aligned}$$

Split the fraction into two terms and ...

... evaluate the limit of each term separately.

$$\text{Therefore, } \lim_{x \rightarrow \infty} \frac{5x - 3}{x} = 5.$$

$$\begin{aligned} \text{b) } \lim_{p \rightarrow 0} (3x^2 - 4px + p^2) &= \lim_{p \rightarrow 0} 3x^2 - \lim_{p \rightarrow 0} 4px + \lim_{p \rightarrow 0} p^2 \\ &= 3x^2 - 0 + 0 = 3x^2 \end{aligned}$$

Evaluate the limit of each term separately.

$$\text{Therefore, } \lim_{p \rightarrow 0} (3x^2 - 4px + p^2) = 3x^2.$$

$$\begin{aligned} \text{c) } \lim_{h \rightarrow 0} \frac{[(x + h)^2 - 6] - (x^2 - 6)}{h} &= \lim_{h \rightarrow 0} \frac{x^2 + 2xh + h^2 - 6 - x^2 + 6}{h} \\ &= \lim_{h \rightarrow 0} \frac{2xh + h^2}{h} \\ &= \lim_{h \rightarrow 0} \frac{h(2x + h)}{h} \\ &= \lim_{h \rightarrow 0} 2x + \lim_{h \rightarrow 0} h \\ &= 2x + 0 = 2x \end{aligned}$$

$$\text{Therefore, } \lim_{h \rightarrow 0} \frac{[(x + h)^2 - 6] - (x^2 - 6)}{h} = 2x.$$

$$\begin{aligned}
 \text{d) } \lim_{x \rightarrow \infty} \frac{3x^2 + 5x - 1}{2x^2 + 1} & \\
 = \lim_{x \rightarrow \infty} \frac{\frac{3x^2}{x^2} + \frac{5x}{x^2} - \frac{1}{x^2}}{\frac{2x^2}{x^2} + \frac{1}{x^2}} & \\
 = \lim_{x \rightarrow \infty} \frac{3 + \frac{5}{x} - \frac{1}{x^2}}{2 + \frac{1}{x^2}} & \\
 = \frac{\lim_{x \rightarrow \infty} 3 + \lim_{x \rightarrow \infty} \frac{5}{x} - \lim_{x \rightarrow \infty} \frac{1}{x^2}}{\lim_{x \rightarrow \infty} 2 + \lim_{x \rightarrow \infty} \frac{1}{x^2}} & \\
 = \frac{3 + 0 - 0}{2 + 0} &
 \end{aligned}$$

Dividing numerator and denominator by largest power of x , i.e. x^2 .

Applying $\lim_{x \rightarrow a} \left[\frac{f(x)}{g(x)} \right] = \frac{L}{K}$
and $\lim_{x \rightarrow a} [f(x) \pm g(x)] = L \pm K$.

Therefore, $\lim_{x \rightarrow \infty} \frac{3x^2 + 5x - 1}{2x^2 + 1} = \frac{3}{2}$.

The limits in parts b) and c) of Example 4 show that in some cases the limit of a function is itself a function.



Connect the limit in Example 4 part d) with the end behaviour of rational functions covered in Section 3.4. Since $\lim_{x \rightarrow \infty} \frac{3x^2 + 5x - 1}{2x^2 + 1} = \frac{3}{2}$, the rational function $y = \frac{3x^2 + 5x - 1}{2x^2 + 1}$ will have a horizontal asymptote of $y = \frac{3}{2}$. In other words, as $x \rightarrow \infty$ or $x \rightarrow -\infty$ the function will approach the value of $y = \frac{3}{2}$ as illustrated in the graph shown.

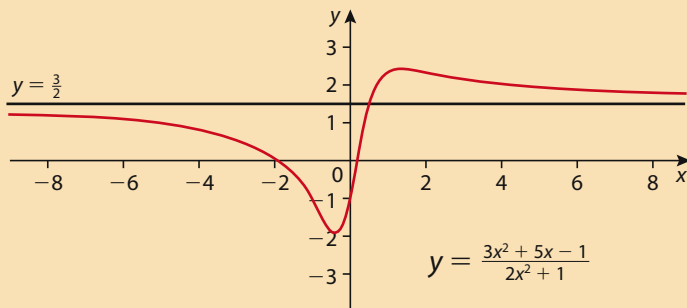

In this section we evaluated limits by guessing and checking with the help of our GDC. This process led us to conclude that $\lim_{x \rightarrow 0} \frac{\sin x}{x} = 1$ and $\lim_{x \rightarrow 0} \cos \frac{x-1}{x} = 0$.

It was reasonable to take this approach since it is not possible to perform algebraic manipulations on these expressions as we did with the expressions in Example 4. However, if possible we should always try to use analytic methods to evaluate a limit as illustrated in the next example.

Example 5

- a) Estimate the value of $\lim_{x \rightarrow 0} \frac{\sqrt{x^2 + 4} - 2}{x^2}$ by evaluating the function $f(x) = \frac{\sqrt{x^2 + 4} - 2}{x^2}$ for $x = \pm 0.5, \pm 0.01, \pm 0.0001, \pm 0.000005, \pm 0.000001$.

- b) Using algebra and properties of limits, evaluate $\lim_{x \rightarrow 0} \frac{\sqrt{x^2 + 4} - 2}{x^2}$.
- c) Comment on the two results.

Solution

- a) A GDC that displays results to an accuracy of ten significant figures gives the following results.

x	$f(x) = \frac{\sqrt{x^2 + 4} - 2}{x^2}$
± 0.5	0.2462112512
± 0.01	0.249998438
± 0.0001	0.25
± 0.000005	0.248
± 0.000003	0.2444444444
± 0.000001	0

The GDC results in the table seem unusual. Initially as x approaches zero from either direction the function values appear to be approaching $\frac{1}{4}$, but then as the function is evaluated for values even closer to zero, the function values continue to decrease to zero.

Is $\lim_{x \rightarrow 0} \frac{\sqrt{x^2 + 4} - 2}{x^2}$ equal to $\frac{1}{4}$ or 0?

If we trust our GDC, we may be tempted to conclude that $\lim_{x \rightarrow 0} \frac{\sqrt{x^2 + 4} - 2}{x^2} = 0$.

- b) We cannot immediately apply the limit property for quotients,

$$\lim_{x \rightarrow a} \left[\frac{f(x)}{g(x)} \right] = \frac{L}{K} \text{ because we obtain the indeterminate form } \frac{0}{0}.$$

We need to use the algebraic technique of multiplying numerator and denominator by the conjugate of the expression in the numerator. This will 'rationalize' the numerator – and may lead to an equivalent expression for which we can apply the quotient property for limits.

$$\begin{aligned} \lim_{x \rightarrow 0} \frac{\sqrt{x^2 + 4} - 2}{x^2} &= \lim_{x \rightarrow 0} \frac{\sqrt{x^2 + 4} - 2}{x^2} \cdot \frac{\sqrt{x^2 + 4} + 2}{\sqrt{x^2 + 4} + 2} \\ &= \lim_{x \rightarrow 0} \frac{(\sqrt{x^2 + 4})^2 - 2^2}{x^2(\sqrt{x^2 + 4} + 2)} \\ &= \lim_{x \rightarrow 0} \frac{x^2 + 4 - 4}{x^2(\sqrt{x^2 + 4} + 2)} \\ &= \lim_{x \rightarrow 0} \frac{\cancel{x^2}}{x^2(\sqrt{x^2 + 4} + 2)} \\ &= \lim_{x \rightarrow 0} \frac{1}{\sqrt{x^2 + 4} + 2} \\ &= \frac{\lim_{x \rightarrow 0} 1}{\lim_{x \rightarrow 0} \sqrt{x^2 + 4} + 2} = \frac{1}{\sqrt{4} + 2} = \frac{1}{4} \end{aligned}$$

Therefore, $\lim_{x \rightarrow 0} \frac{\sqrt{x^2 + 4} - 2}{x^2} = \frac{1}{4}$.

- c) Because of memory limitations a GDC will sometimes give a false value. Because $\sqrt{x^2 + 4}$ is very close to 2 when x is very small, a GDC will eventually consider $\sqrt{x^2 + 4}$ to be equal to 2.000 000 00 ... (to as many digits as the GDC is capable of computing) when x is sufficiently small. Your GDC is a very powerful tool, but like any tool it does have its limitations.

Exercise 13.1

In questions 1–4, evaluate each limit algebraically and then confirm your result by means of a table or graph on your GDC.

$$1 \quad \lim_{n \rightarrow \infty} \frac{1 + 4n}{n} \qquad 2 \quad \lim_{h \rightarrow 0} (3x^2 + 2hx + h^2)$$

$$3 \quad \lim_{d \rightarrow 0} \frac{(x + d)^2 - x^2}{d} \qquad 4 \quad \lim_{x \rightarrow 3} \frac{x^2 - 9}{x - 3}$$

In questions 5–7, investigate the limit of the expression (if it exists) as $x \rightarrow \infty$ by evaluating the expression for the following values of x : 10, 50, 100, 1000, 10000 and 1 000 000. Hence, make a conjecture for the value of each limit.

$$5 \quad \lim_{x \rightarrow \infty} \frac{3x + 2}{x^2 - 3} \qquad 6 \quad \lim_{x \rightarrow \infty} \frac{5x - 6}{2x + 5} \qquad 7 \quad \lim_{x \rightarrow \infty} \frac{3x^2 + 2}{x - 3}$$

In questions 8–13, find the limit, if it exists.

$$8 \quad \lim_{x \rightarrow 4} \frac{x - 4}{x^2 - 16} \qquad 9 \quad \lim_{x \rightarrow 1} \frac{x^2 + x - 2}{x^2 - 1}$$

$$10 \quad \lim_{x \rightarrow 0} \frac{\sqrt{2 + x} - \sqrt{2}}{x} \quad \bullet \text{ Hint: multiply numerator and denominator by conjugate of numerator}$$

$$11 \quad \lim_{x \rightarrow \infty} \frac{x^3 - 1}{4x^3 - 3x + 1}$$

$$12 \quad \lim_{x \rightarrow 0} \frac{\tan x}{x} \quad \bullet \text{ Hint: rewrite } \tan x \text{ as } \frac{\sin x}{\cos x} \text{ and apply property } \lim_{x \rightarrow 0} [f(x) \cdot g(x)] = L \cdot K$$

$$13 \quad \lim_{\theta \rightarrow 0} \frac{\sin 3\theta}{\theta} \quad \bullet \text{ Hint: rewrite } \frac{\sin 3\theta}{\theta} \text{ as } \left(3 \frac{\sin 3\theta}{3\theta}\right) \text{ and apply } \lim_{x \rightarrow 0} \frac{\sin x}{x} = 1$$

- 14 Use the graphing or table capabilities of your GDC to investigate the values of the expression $\left(1 + \frac{1}{c}\right)^c$ as c increases without bound (i.e. $c \rightarrow \infty$). Explain the significance of the result.
- 15 If it is known that the line $y = 3$ is a horizontal asymptote for the function $f(x)$, state the value of each of the following two limits: $\lim_{x \rightarrow \infty} f(x)$ and $\lim_{x \rightarrow -\infty} f(x)$.
- 16 If it is known that the line $x = a$ is a vertical asymptote for the function $g(x)$ and $g(x) > 0$, what conclusion can be made about $\lim_{x \rightarrow a} g(x)$?
- 17 State the equations of all horizontal and vertical asymptotes for the following functions. Confirm using your GDC.

$$a) f(x) = \frac{3x - 1}{1 + x} \qquad b) g(x) = \frac{1}{(x - 2)^2} \qquad c) g(x) = \frac{1}{x - a} + b$$

$$d) R(x) = \frac{2x^2 - 3}{x^2 - 9} \qquad e) d(x) = \frac{5 - 3x}{x^2 - 5x} \qquad f) p(x) = \frac{x^2 - 4}{x - 4}$$

For questions 18 and 19, a) use your GDC to estimate the limit, and b) use analytic methods to evaluate the limit.

$$18 \lim_{x \rightarrow 2} \frac{\sqrt{x^2 + 5} - 3}{x^2 - 2x}$$

$$19 \lim_{x \rightarrow +\infty} \frac{4x - 1}{\sqrt{x^2 + 2}}$$

$$20 \text{ Show that } \lim_{h \rightarrow 0} \frac{\sqrt{x+h} - \sqrt{x}}{h} = \frac{1}{2\sqrt{x}}.$$

$$21 \text{ Show that } \lim_{h \rightarrow 0} \frac{\frac{1}{x+h} - \frac{1}{x}}{h} = -\frac{1}{x^2}.$$

13.2 The derivative of a function: definition and basic rules

Tangent lines and the slope (gradient) of a curve

In Section 1.6, we reviewed linear equations in two variables. And, later in Section 2.1, we established that any non-vertical line represents a function for which we typically assign the variables x and y for values in the domain and range of the function, respectively. Any linear function can be written in the form $y = mx + c$. This is the slope-intercept form for a linear equation, where m is the slope (or gradient) of the graph and c is the y -coordinate of the point at which the graph intersects the y -axis (i.e. the y -intercept). The value of the slope m , defined as $m = \frac{y_2 - y_1}{x_2 - x_1} = \frac{\text{vertical change}}{\text{horizontal change}}$, will be the same for any pair of points, (x_1, y_1) and (x_2, y_2) , on the line. An essential characteristic of the graph of a linear function is that it has a constant slope. This is not true for the graphs of non-linear functions.

Consider a person walking up the side of a pitched roof as shown in Figure 13.4. At *any* point along the line segment PQ the person is experiencing a slope of $\frac{3}{4}$. Now consider someone walking up the curve shown in Figure 13.5, which passes through the three points A , B and C . As the person walks along the curve from A to C , he/she will experience a steadily increasing slope. The slope is continually changing from one point to the next along the curve. Therefore, it is incorrect to say that a non-linear function, whose graph is a curve, has *a* slope – it has *infinitely many* slopes. We need a means to determine the slope of a non-linear function *at a specific point* on its graph.

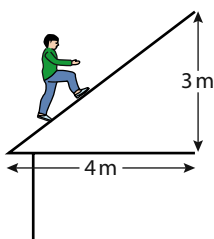
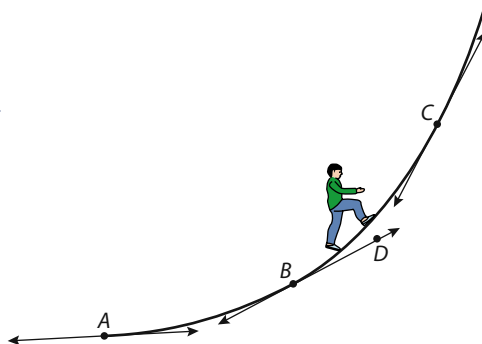

Figure 13.4 Slope of a straight line.

Figure 13.5 Slope of a curve.



Imagine if the slope of the curve in Figure 13.5 stopped increasing (remained constant) after point B . From that point on, a person walking up the curve would move along a line with a slope equal to the slope of the curve at point B . This line – containing point D in the diagram – only ‘touches’

the curve once at B . Line (BD) is **tangent** to the curve at point B . Therefore, finding the slope of the line that is tangent to a curve at a certain point will give us the slope of the curve at that point.

Finding the slope of a curve at a point – or better – finding a rule (function) that gives us the slope at any point on the curve is very useful information in many applications. The slope of a line, or of a curve at a point, is a measure of how fast variable y is changing as variable x changes. **The slope represents the rate of change of y with respect to x .** To find the slope of a tangent line, we first need to clarify what it means to say that a line is tangent to a curve at a point. Then we can establish a method to find the tangent line at a point.

The three graphs in Figure 13.6 show different configurations of tangent lines. A tangent line may cross or intersect the graph at one or more points.

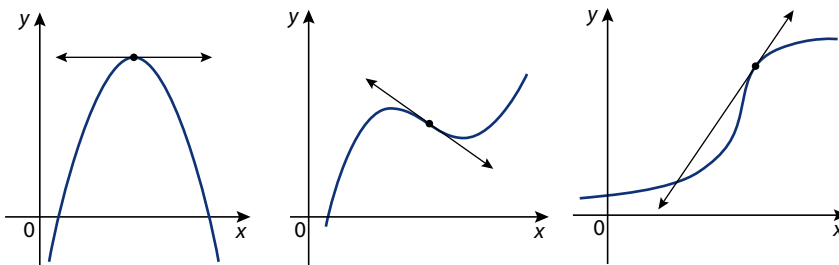

For many functions, the graph has a tangent at *every* point. Informally, a function is said to be *smooth* if it has this property. Any linear function is certainly smooth, since the tangent at each point coincides with the original graph. However, some graphs are not smooth at every point. Consider the point $(0, 0)$ on the graph of the function $y = |x|$ (Figure 13.7). Zooming in on $(0, 0)$ will always produce a V-shape rather than smoothing out to appear more and more linear. Therefore, there is no tangent to the graph at this point.



The slope (gradient) of a curve at a point is the slope of the line that is tangent to the curve at that point.

• **Hint:** The word ‘curve’ can often mean the same as ‘function’, even if the function is linear.

Figure 13.6 Different configurations of lines tangent to a curve.

Figure 13.7 $y = |x|$

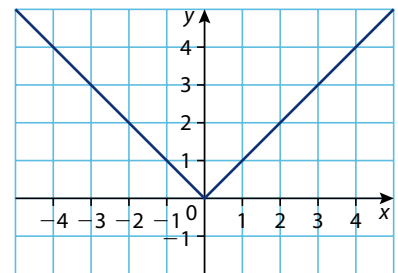
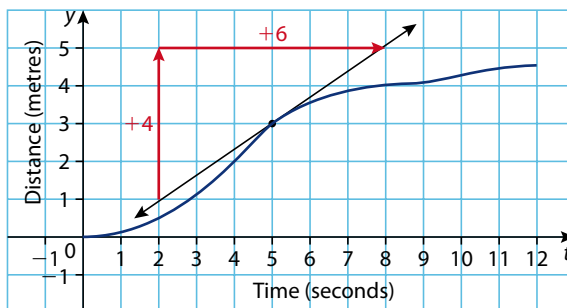

Figure 13.8 Estimating the slope of a tangent line.



One way to find the tangent line of a graph at a particular point is to make a visual estimate. Figure 13.8 reproduces the time-distance graph for an object’s motion from the previous section (Figure 13.1). The slope at any point (t, y) on the curve will give us the rate of change of the distance y with respect to time t , in other words the object’s **instantaneous velocity** at time t . In the figure, an estimate of the line tangent to the curve at $(5, 3)$ has been drawn. Reading from the graph, the slope appears to be $\frac{4}{6} = \frac{2}{3}$. Or,

in other words, the object has a velocity of approximately 0.667 m/s at the instant when $t = 5$ seconds.

A more precise method of finding tangent lines makes use of a secant line and a limit process. Suppose that f is any smooth function, so the tangent to its graph exists at all points. A **secant line** (or chord) is drawn through the point for which we are trying to find a tangent to f and a second point on the graph of f , as shown in Figure 13.9a. If P is the point of tangency with coordinates $(x, f(x))$, choose a point Q to be horizontally some h units away. Hence, the coordinates of point Q are $(x + h, f(x + h))$. Then the slope of

the secant line (PQ) is $m_{\text{sec}} = \frac{f(x + h) - f(x)}{(x + h) - x} = \frac{f(x + h) - f(x)}{h}$.

The right side of this equation is often referred to as a **difference quotient**. The numerator is the change in y , and the denominator h is the change in x . The limit process of achieving better and better approximations for the slope of the tangent at P consists of finding the slope of the secant (PQ) as Q moves ever closer to P , as shown in the graphs in Figure 13.9b and Figure 13.9c. In doing so, the value of h will approach zero.

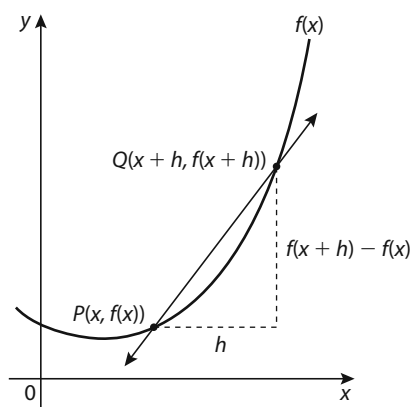

Figure 13.9a

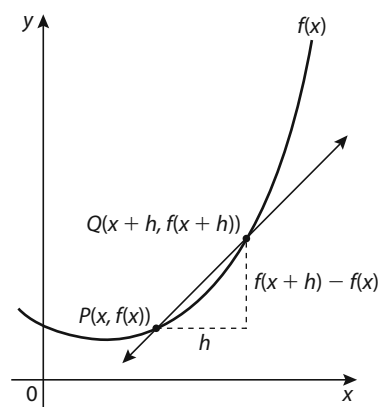

Figure 13.9b

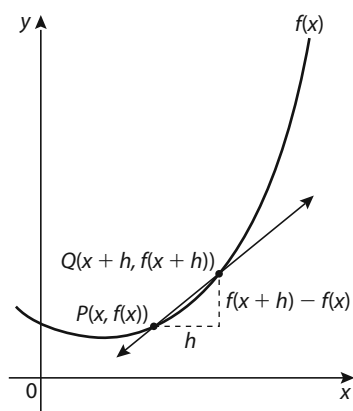

Figure 13.9c As h tends to zero, the secant line becomes a better approximation of the tangent line.

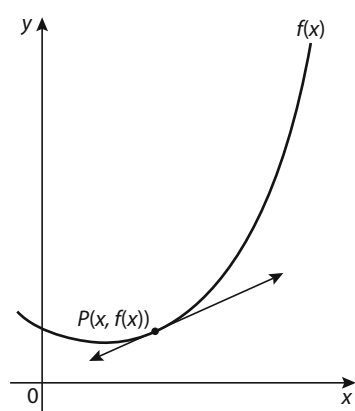

Figure 13.9d Tangent to f at point P .

By evaluating a limit of the slope of the secant lines as h approaches zero, we can find the exact slope of the tangent line at $P(x, f(x))$.

The slope (gradient) of a curve at a point

The slope of the curve $y = f(x)$ at the point $(x, f(x))$ is equal to the slope of its tangent line at $(x, f(x))$, and is given by

$$m_{\text{tan}} = \lim_{h \rightarrow 0} m_{\text{sec}} = \lim_{h \rightarrow 0} \frac{f(x+h) - f(x)}{h}$$

provided that this limit exists.

Let's apply the definition of the slope of a curve at a point to find a rule, or function, for the slope of all of the tangent lines to a curve.

Example 6

Find a rule for the slopes of the tangent lines to the graph of $f(x) = x^2 + 1$. Use this rule to find the exact slope of the curve at the point where $x = 0$ and at the point where $x = 1$.

Solution

Let $(x, f(x))$ represent any point on the graph of f . By definition, the slope of the tangent line at $(x, f(x))$ is:

$$\begin{aligned} m &= \lim_{h \rightarrow 0} \frac{f(x+h) - f(x)}{h} = \lim_{h \rightarrow 0} \frac{[(x+h)^2 + 1] - [x^2 + 1]}{h} \\ &= \lim_{h \rightarrow 0} \frac{[x^2 + 2xh + h^2 + 1] - [x^2 + 1]}{h} \\ &= \lim_{h \rightarrow 0} \frac{x^2 - x^2 + 2xh + h^2 + 1 - 1}{h} \\ &= \lim_{h \rightarrow 0} \frac{h(2x + h)}{h} \\ &= \lim_{h \rightarrow 0} (2x + h) \\ &= 2x \end{aligned}$$

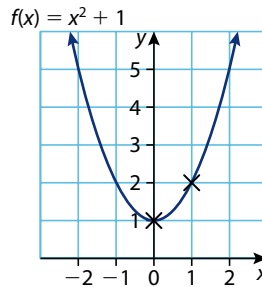

Therefore, the slope at any point $(x, f(x))$ on the graph of f is $2x$.

At the point where $x = 0$, the slope is $2(0) = 0$. This makes visual sense because the point $(0, 1)$ is the vertex of the parabola $y = x^2 + 1$, and we expect that the tangent at this point is a horizontal line with a slope of zero. At the point where $x = 1$, the slope is $2(1) = 2$. This also makes visual sense because moving along the curve from $(0, 1)$ to $(1, 2)$ the slope is steadily increasing.

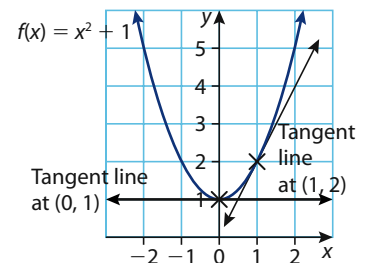

i The word 'secant', as applied to a line, comes from the Latin word *secare*, meaning to cut. The word 'tangent' comes from the Latin verb *tangere*, meaning to touch.

In Example 6, from the function $f(x) = x^2 + 1$ we used the limit process to derive another function with the rule $2x$. With this derived function we can compute the slope (gradient) of the graph of $f(x)$ at a point from simply inputting the x -coordinate of the point. This *derived* function is called the **derivative** of f at x . It is given the notation $f'(x)$, which is commonly read as 'f prime of x ', or simply, 'the derivative of f of x '.

The derivative and differentiation

- The **derivative**, $f'(x)$, at a point x in the domain of f is the slope (gradient) of the graph of f at $(x, f(x))$, and is given by

$$f'(x) = \lim_{h \rightarrow 0} \frac{f(x+h) - f(x)}{h}$$

provided that this limit exists.

- If the derivative exists at each point of the domain of f , we say that f is **smooth**.
- The process of finding the derivative, $f'(x)$, is called **differentiation**.
- If $y = f(x)$, then $f'(x)$ is a formula for the instantaneous **rate of change** of y with respect to x .

If finding the derivative of a function indicated with the function notation $f(x)$, then – as shown already – the derivative is usually denoted as $f'(x)$. However, there are two other notations with which you should be familiar. Commonly, if a function is given as y in terms of x , then the derivative is denoted as y' , read as 'y

prime.' The notation $\frac{dy}{dx}$ is also often used to indicate a derivative, and is read as 'the derivative of y with respect to x '. Note: $\frac{dy}{dx}$ is not a fraction. If, for example, $y = x^2 + 1$, the derivative can be denoted by writing $\frac{d}{dx}(x^2 + 1) = 2x$. This is read as 'the derivative of $x^2 + 1$ with respect to x is $2x$ '.



Differentiating from first principles

Depending on the particular purpose that you have in differentiating a function, you can consider the derivative as giving the slope of the graph of the function *or* the rate of change of the dependent variable (commonly y) with respect to the independent variable (commonly x). Both interpretations are useful and widely applied.

Using the limit definition directly to find the derivative of a function (as we did in Example 6) is often called 'differentiating from first principles'.

Example 7

Differentiating from first principles, find the derivative of $f(x) = x^3$.

Solution

$$\begin{aligned} f'(x) &= \lim_{h \rightarrow 0} \frac{f(x+h) - f(x)}{h} = \lim_{h \rightarrow 0} \frac{(x+h)^3 - x^3}{h} \\ &= \lim_{h \rightarrow 0} \frac{(x+h)(x+h)^2 - x^3}{h} \\ &= \lim_{h \rightarrow 0} \frac{(x+h)(x^2 + 2hx + h^2) - x^3}{h} \\ &= \lim_{h \rightarrow 0} \frac{x^3 + 3hx^2 + 3h^2x + h^3 - x^3}{h} \\ &= \lim_{h \rightarrow 0} \frac{h(3x^2 + 3hx + h^2)}{h} \\ &= \lim_{h \rightarrow 0} (3x^2 + 3hx + h^2) \\ &= 3x^2 \end{aligned}$$

Therefore, the derivative of $f(x) = x^3$ is $f'(x) = 3x^2$.

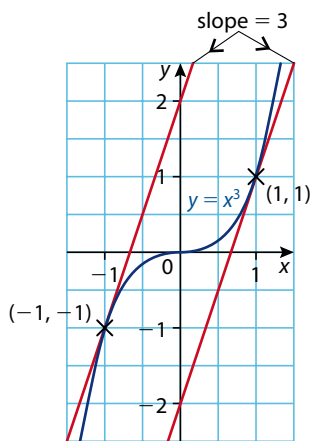

Figure 13.10 Two tangents to $y = x^3$ that are parallel.

As in Example 6, the result for Example 7 is a function that gives us the slope at any point on the graph of $y = x^3$. For example, the points $(1, 1)$ and $(-1, -1)$ both lie on $y = x^3$, and the slopes at these points are respectively $f'(1) = 3(1)^2 = 3$ and $f'(-1) = 3(-1)^2 = 3$. Hence, the tangents at these points will be parallel, as shown in Figure 13.10.

Let's examine the relationship between the slopes of tangents to the curve $f(x) = x^2 + 1$ (Example 6) and slopes of tangents to $g(x) = x^2$. Recall that we found the derivative of $f(x)$ to be $f'(x) = 2x$. It appears from the graphs of f and g , in Figure 13.11, that the slopes of tangents at points with the same x -coordinate are equal. For example, the tangent to g at the point $(1, 2)$ looks parallel to the tangent to f at $(1, 1)$, as shown in Figure 13.11. This implies that the derivatives of the two functions are equal. Rather than confirming this conjecture by finding the derivative of $g(x) = x^2$ by first principles (i.e. using the limit definition), let's use the graphical and computing power of our GDC. Any GDC model is capable of computing the slope of a curve at a point – either on the GDC's 'home' screen, or its graphing screen. The screen images below show computing derivative values for $y = x^2$ on the 'home' screen.

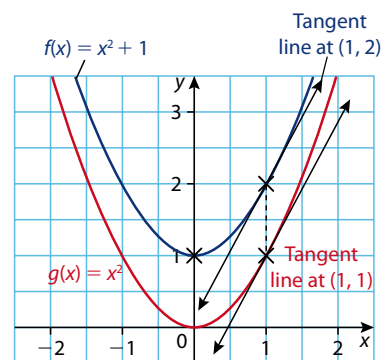

Figure 13.11

This command finds the value of the derivative of $y = x^2$ in terms of x , at the point $x = 1$.



The exact command name and syntax for computing the value of a derivative at a point may vary from one GDC model to another.

```
MATH NUM CPX PRB
1: ▸Frac
2: ▸Dec
3: 3
4: 3√(
5: x√
6: fMin(
7: fMax(
```

```
MATH NUM CPX PRB
4: 3√(
5: x√
6: fMin(
7: fMax(
8: nDeriv(
9: fnInt(
0: Solver...
```

```
nDeriv(X^2,X,1) 2
```

```
nDeriv(X^2,X,1) 2
nDeriv(X^2,X,2) 4
nDeriv(X^2,X,3) 6
```

```
6
nDeriv(X^2,X,-1) -2
nDeriv(X^2,X,17) 34
nDeriv(X^2,X,-9) -18
```

Our GDC results confirm our conjecture that the derivative of $g(x) = x^2$ is $g'(x) = 2x$.

Example 8

From first principles, find:

- a) y' given $y = 3x^2 + 2x$ b) $\frac{dy}{dx}$ given $y = \frac{1}{x}$

Solution

We will apply the definition of the derivative, $f'(x) = \lim_{h \rightarrow 0} \frac{f(x+h) - f(x)}{h}$, in both a) and b).

$$\begin{aligned} \text{a) } y' &= \lim_{h \rightarrow 0} \frac{[3(x+h)^2 + 2(x+h)] - (3x^2 + 2x)}{h} \\ &= \lim_{h \rightarrow 0} \frac{(3x^2 + 6hx + 3h^2 + 2x + 2h) - (3x^2 + 2x)}{h} \\ &= \lim_{h \rightarrow 0} \frac{6hx + 3h^2 + 2h}{h} \\ &= \lim_{h \rightarrow 0} (6x + 3h + 2) \Rightarrow y' = 6x + 2 \end{aligned}$$

$$\begin{aligned}
 \text{b) } \frac{dy}{dx} &= \frac{d}{dx} \left(\frac{1}{x} \right) = \lim_{h \rightarrow 0} \frac{\frac{1}{x+h} - \frac{1}{x}}{h} \\
 &= \lim_{h \rightarrow 0} \frac{\frac{x}{x(x+h)} - \frac{x+h}{x(x+h)}}{h} \\
 &= \lim_{h \rightarrow 0} \left(\frac{\frac{-h}{x(x+h)}}{\frac{h}{1}} \right) \\
 &= \lim_{h \rightarrow 0} \left(\frac{-h}{x(x+h)} \cdot \frac{1}{h} \right) \\
 &= \lim_{h \rightarrow 0} \left(\frac{-1}{x^2 + hx} \right) \Rightarrow \frac{d}{dx} \left(\frac{1}{x} \right) = -\frac{1}{x^2} \text{ or } \frac{d}{dx} (x^{-1}) = -x^{-2}
 \end{aligned}$$

Basic differentiation rules

We have now established the following results:

- If $f(x) = x^2$, then $f'(x) = 2x$.
- If $f(x) = x^2 + 1$, then $f'(x) = 2x$.
- If $f(x) = 3x^2 + 2x$, then $f'(x) = 6x + 2$.
- If $f(x) = x^3$, then $f'(x) = 3x^2$.
- If $f(x) = x^{-1}$, then $f'(x) = -x^{-2}$.

In addition, we know that if $f(x) = x$, then $f'(x) = 1$, since the line $y = x$ has a constant slope equal to 1; and that if $f(x) = 1$, then $f'(x) = 0$ because the line $y = 1$ is horizontal and thus has a constant slope equal to 0.

Furthermore, the graph of any function $f(x) = c$, where c is a constant, is a horizontal line, confirming that if $f(x) = c$, $c \in \mathbb{R}$, then $f'(x) = 0$. In other words, the derivative of a constant is zero. This leads to our first basic rule of differentiation.

The constant rule

The derivative of a constant function is zero. That is, given c is a real number, and if $f(x) = c$, then $f'(x) = 0$.

These following results:

$$\begin{aligned}
 f(x) = x^{-1} &\Rightarrow f'(x) = -x^{-2} \\
 f(x) = x^0 = 1 &\Rightarrow f'(x) = 0 \\
 f(x) = x^1 = x &\Rightarrow f'(x) = 1 \\
 f(x) = x^2 &\Rightarrow f'(x) = 2x \\
 f(x) = x^3 &\Rightarrow f'(x) = 3x^2
 \end{aligned}$$

can be summarized in the single statement:

$$\text{if } f(x) = x^n \text{ then } f'(x) = nx^{n-1} \text{ for } n = -1, 0, 1, 2, 3$$

In fact, this statement is true not just for these values but for *any* value of n that is a rational number ($n \in \mathbb{Q}$). This leads to our second basic rule of differentiation.

The derivative of x^n

Given n is a rational number, and if $f(x) = x^n$, then $f'(x) = nx^{n-1}$.

Functions of the form $f(x) = x^n$ are called **power functions**, so the differentiation rule

$\frac{d}{dx}(x^n) = nx^{n-1}$ gives the rule for differentiating power functions – and is often referred to as the **power rule**.

Recall from Chapter 4 the binomial theorem for positive integers

$$(a + b)^n = \sum_{r=0}^n \binom{n}{r} a^{n-r} b^r.$$

Applying this to the limit definition of the derivative gives,

$$\begin{aligned} \frac{d}{dx}(x^n) &= \lim_{h \rightarrow 0} \frac{(x+h)^n - x^n}{h} \\ &= \lim_{h \rightarrow 0} \frac{\left(\binom{n}{0} x^n + \binom{n}{1} x^{n-1} h + \binom{n}{2} x^{n-2} h^2 + \dots + \binom{n}{n-1} x h^{n-1} + \binom{n}{n} h^n \right) - x^n}{h} \\ &= \lim_{h \rightarrow 0} \frac{\left(x^n + n x^{n-1} h + \frac{1}{2} n(n-1) x^{n-2} h^2 + \dots + n x h^{n-1} + h^n \right) - x^n}{h} \\ &= \lim_{h \rightarrow 0} n x^{n-1} + \lim_{h \rightarrow 0} \frac{1}{2} n(n-1) x^{n-2} h + \dots + \lim_{h \rightarrow 0} n x h^{n-2} + \lim_{h \rightarrow 0} h^{n-1} \\ &= n x^{n-1} + 0 + \dots + 0 + 0 \\ &= n x^{n-1} \end{aligned}$$

Therefore, $\frac{d}{dx}(x^n) = n x^{n-1}$.

Another basic rule of differentiation is suggested by our result that the derivative of $f(x) = x^2 + 1$ is $f'(x) = 2x$. The derivative of a sum of a number of terms is obtained by differentiating each term separately – i.e. differentiating ‘term-by-term’. That is,

$$\frac{d}{dx}(x^2 + 1) = \frac{d}{dx}(x^2) + \frac{d}{dx}(1) = 2x + 0 = 2x.$$

The sum and difference rule

If $f(x) = g(x) \pm h(x)$ then $f'(x) = g'(x) \pm h'(x)$.

The sum rule for derivatives can help us give a very convincing justification of our first differentiation rule: the constant rule. The fact that the derivative of a constant must be zero can be verified by considering the transformation of the graph of a function (Section 2.4). The graph of the function $f(x) + c$, where $c \in \mathbb{R}$, is a vertical translation by c units of the graph of $f(x)$. As Figure 13.12 illustrates, when the graph of a function is translated vertically its shape is preserved. Hence, the slope of the tangent line to the graph of $f(x) + c$ will be the same as that for $f(x)$ at a particular value of x . This means that the derivatives for the two functions must be equal. That is,

$$\begin{aligned} \frac{d}{dx}[f(x) + c] &= \frac{d}{dx}[f(x)] \\ \frac{d}{dx}[f(x)] + \frac{d}{dx}(c) &= \frac{d}{dx}[f(x)] \end{aligned}$$

This is only true if $\frac{d}{dx}(c) = 0$.

Figure 13.12 Translating the graph of a function vertically does not alter the slope of the tangent line at a particular value of x . Hence the derivatives of the two functions are equal.

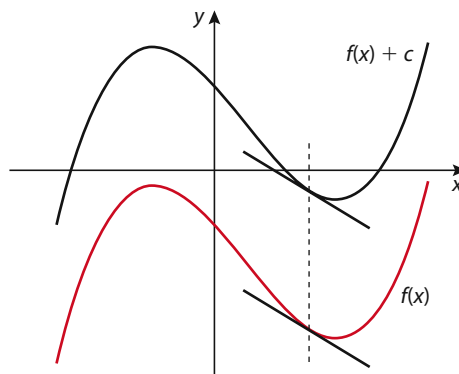

A fourth basic rule of differentiation is illustrated by our result that the derivative of $f(x) = 3x^2 + 2x$ is $f'(x) = 6x + 2$. Using the sum rule, $f'(x) = \frac{d}{dx}(3x^2 + 2x) = \frac{d}{dx}(3x^2) + \frac{d}{dx}(2x) = 6x + 2$. The fact that $\frac{d}{dx}(3x^2) = 6x$ suggests that $3 \cdot \frac{d}{dx}(x^2) = 3 \cdot 2x = 6x$. In other words, the derivative of a function being multiplied by a constant is equal to the constant multiplying the derivative of the function.

The constant multiple rule

If $f(x) = c \cdot g(x)$ then $f'(x) = c \cdot g'(x)$.

As mentioned before, and as you have seen, there are different notations used for indicating a derivative or differentiation. These can be traced back to the fact that calculus was first developed by Isaac Newton (1642–1727) and Gottfried Leibniz (1646–1716) independently of each other – and hence introduced different symbols for methods of calculus. The ‘prime’ notations y' and $f'(x)$ come from notations that Newton used for derivatives. The $\frac{dy}{dx}$ notation is similar to that used by Leibniz for indicating differentiation. Each has its advantages and disadvantages. For example, it is often easier to write our four basic rules of differentiation using Leibniz notation as shown below.

Constant rule: $\frac{d}{dx}(c) = 0, c \in \mathbb{R}$

Power rule: $\frac{d}{dx}(x^n) = nx^{n-1}, n \in \mathbb{Q}$

Sum and difference rule: $\frac{d}{dx}[g(x) + h(x)] = \frac{d}{dx}[g(x)] + \frac{d}{dx}[h(x)]$

Constant multiple rule: $\frac{d}{dx}[c \cdot f(x)] = c \cdot \frac{d}{dx}[f(x)], c \in \mathbb{R}$

Example 9

For each function: (i) find the derivative using the basic differentiation rules; (ii) find the slope of the graph of the function at the indicated points; and (iii) use your GDC to confirm your answer for (ii).

Function

a) $f(x) = x^3 + 2x^2 - 15x - 13$

b) $f(x) = (2x - 7)^2$

c) $f(x) = 3\sqrt{x} - 6$

d) $f(x) = \frac{x^4}{4} - \frac{3x^3}{2} - 2x^2 + \frac{15x}{2} + \frac{3}{4}$

Points

$(-3, 23), (3, -13)$

$(2, 9), (\frac{7}{2}, 0)$

$(4, 0), (9, 3)$

$(5, -43), (0, 0)$

Solution

$$\begin{aligned} \text{a) (i) } \frac{d}{dx}(x^3 + 2x^2 - 15x - 13) &= \frac{d}{dx}(x^3) + 2 \cdot \frac{d}{dx}(x^2) - 15 \cdot \frac{d}{dx}(x) - \frac{d}{dx}(13) \\ &= 3x^2 + 2(2x) - 15(1) - 0 \\ &= 3x^2 + 4x - 15 \end{aligned}$$

Therefore, the derivative of $f(x) = x^3 + 2x^2 - 15x - 13$ is
 $f'(x) = 3x^2 + 4x - 15$.

(ii) Slope of curve at $(-3, 23)$ is $f'(-3) = 3(-3)^2 + 4(-3) - 15$
 $= 27 - 12 - 15 = 0$.

We should observe a horizontal tangent (slope = 0) to the curve at $(-3, 23)$.

Slope of curve at $(3, -13)$ is $f'(3) = 3(3)^2 + 4(3) - 15$
 $= 27 + 12 - 15 = 24$.

We should observe a very steep tangent (slope = 24) to the curve at $(3, -13)$.

(iii) Not only can we use the GDC to compute the value of the derivative at a particular value of x on the 'home' screen, but we can also do it on the graph screen.

```
Plot1 Plot2 Plot3
\Y1= X^3+2X^2-15X-13
\Y2=
\Y3=
\Y4=
\Y5=
\Y6=
```

```
WINDOW
Xmin=-6
Xmax=6
Xscl=1
Ymin=-40
Ymax=40
Yscl=5
Xres=1
```

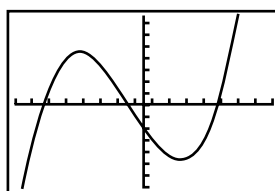

```
CALCULATE
1:value
2:zero
3:minimum
4:maximum
5:intersect
6:dy/dx
7:∫f(x)dx
```

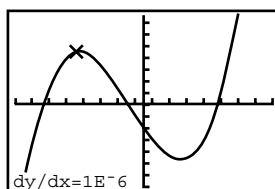
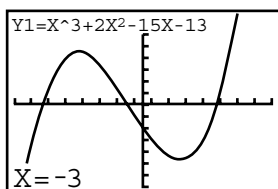

The GDC computes a slope of $1E^{-6}$ at the point $(-3, 23)$.

$$(1E^{-6} = 1 \times 10^{-6} = 0.000001)$$

Although the method the GDC uses is very accurate, sometimes there is a small amount of error in its calculation. This most commonly occurs when performing calculus computations (e.g. the value of the derivative at a point). $1E^{-6} = 0.000001$ is very close to zero which is the exact value of the derivative. Observe that the graph of $y = x^3 + 2x^2 - 15x - 13$ appears to have a 'turning point' at $(-3, 23)$, confirming that a line tangent to the curve at that point would be horizontal.

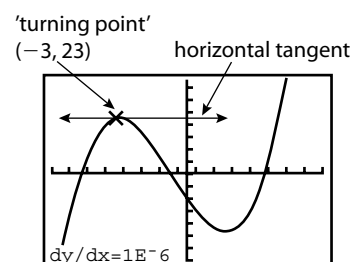

Let's check on our GDC that the slope of the curve is 24 at $(3, -13)$. Again, the GDC exhibits a small amount of error in its result.

Most GDCs are also capable of drawing a tangent at a point and displaying its equation as shown in the final screen image below.

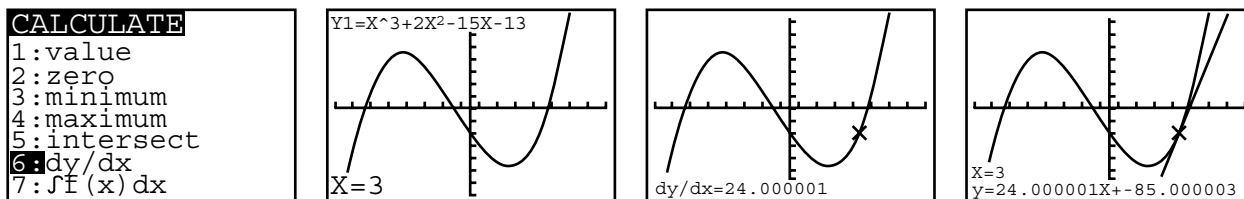

The equation of the tangent line at $(3, -13)$ is $y = 24x - 85$. We will look at finding the equations of tangent lines analytically in the last section of the chapter.

$$\begin{aligned} \text{b) (i) } \frac{d}{dx}[(2x - 7)^2] &= \frac{d}{dx}[(2x - 7)(2x - 7)] && \text{Differentiate term-by-term} \\ & && \text{after expanding.} \\ &= \frac{d}{dx}(4x^2 - 28x + 49) \\ &= 4 \frac{d}{dx}(x^2) - 28 \frac{d}{dx}(x) + \frac{d}{dx}(49) \\ &= 8x - 28 + 0 \end{aligned}$$

Therefore, the derivative of $f(x) = (2x - 7)^2$ is $f'(x) = 8x - 28$.

$$\text{(ii) Slope of curve at } (2, 9) \text{ is } f'(2) = 8(2) - 28 = -12.$$

$$\text{Slope of curve at } \left(\frac{7}{2}, 0\right) \text{ is } f'\left(\frac{7}{2}\right) = 8\left(\frac{7}{2}\right) - 28 = 0.$$

Thus, we should observe a horizontal tangent to the curve at $\left(\frac{7}{2}, 0\right)$.

(iii)

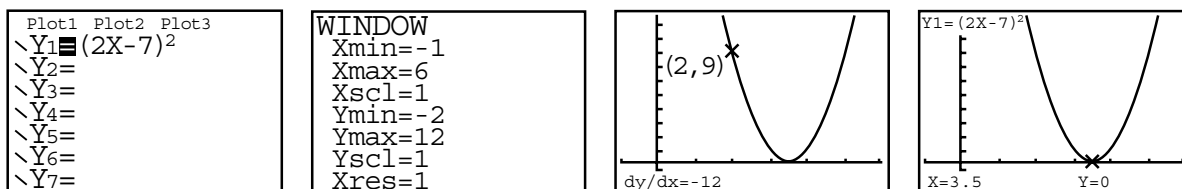

There's no error this time in the GDC's computation of the slope at $(2, 9)$. The vertex of the parabola is at $\left(\frac{7}{2}, 0\right)$, confirming that it has a horizontal tangent at that point.

$$\begin{aligned} \text{c) (i) } \frac{d}{dx}(3\sqrt{x} - 6) &= 3 \frac{d}{dx}(x^{\frac{1}{2}}) - \frac{d}{dx}(6) \\ &= 3\left(\frac{1}{2}x^{-\frac{1}{2}}\right) - 0 \\ &= \frac{3}{2x^{\frac{1}{2}}} \end{aligned}$$

Therefore, the derivative of $f(x) = 3\sqrt{x} - 6$ is $f'(x) = \frac{3}{2x^{\frac{1}{2}}}$ or $f'(x) = \frac{3}{2\sqrt{x}}$.

(ii) Slope of curve at (4, 0) is $f'(4) = \frac{3}{2\sqrt{4}} = \frac{3}{4}$.

Slope of curve at (9, 3) is $f'(9) = \frac{3}{2\sqrt{9}} = \frac{1}{2}$.

Thus, because the slope at $x = 9$ is less than that at $x = 4$, we should observe the graph of the equation becoming less steep as we move along the curve from $x = 4$ to $x = 9$.

(iii)

```
Plot1 Plot2 Plot3
\Y1=3√(X)-6
\Y2=
\Y3=
\Y4=
\Y5=
\Y6=
\Y7=
```

```
WINDOW
Xmin=-1
Xmax=10
Xscl=1
Ymin=-7
Ymax=4
Yscl=1
Xres=1
```

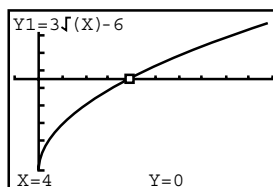

```
nDeriv(3√(X)-6,X
,4)
.750000006
nDeriv(3√(X)-6,X
,9)
.5000000009
```

The slope of the graph of $y = 3\sqrt{x} - 6$ appears to steadily decrease as x increases. Let's check the results for (ii) by evaluating the derivative at a point on the 'home' screen. The GDC confirms the slopes for the curve when $x = 4$ and $x = 9$, but again the GDC computations have incorporated a small amount of error.

d) (i)
$$\begin{aligned} \frac{d}{dx} \left(\frac{x^4}{4} - \frac{3x^3}{2} - 2x^2 + \frac{15x}{2} + \frac{3}{4} \right) \\ = \frac{1}{4} \frac{d}{dx} (x^4) - \frac{3}{2} \frac{d}{dx} (x^3) - 2 \frac{d}{dx} (x^2) + \frac{15}{2} \frac{d}{dx} (x) + \frac{d}{dx} \left(\frac{3}{4} \right) \\ = \frac{1}{4} (4x^3) - \frac{3}{2} (3x^2) - 2 \frac{d}{dx} (2x) + \frac{15}{2} (1) + 0 \\ = x^3 - \frac{9x^2}{2} - 4x + \frac{15}{2} \end{aligned}$$

Therefore, the derivative of $f(x) = \frac{x^4}{4} - \frac{3x^3}{2} - 2x^2 + \frac{15x}{2} + \frac{3}{4}$

is $f'(x) = x^3 - \frac{9x^2}{2} - 4x + \frac{15}{2}$.

(ii) Slope of curve at (5, -43) is $f'(5) = 5^3 - \frac{9(5)^2}{2} - 4(5) + \frac{15}{2} = 0$.

Thus, there should be a horizontal tangent to the curve at (5, -43).

Slope of curve at (0, 0) is $f'(0) = \frac{15}{2}$.

(iii) Your GDC is not capable of computing the derivative function – only the specific value of the derivative for a given value of x . However, we can have the GDC graph the values of the derivative over a given *interval* of x . We can then graph the derivative function found from differentiation rules (result from (i)) and see if the two graphs match.

```
Plot1 Plot2 Plot3
\Y1=X^4/4-(3X^3)/2-2X^2+15X/2+3/4
\Y2=
\Y3=
\Y4=
\Y5=
```

```
WINDOW
Xmin=-4
Xmax=8
Xscl=1
Ymin=-50
Ymax=50
Yscl=10
Xres=1
```

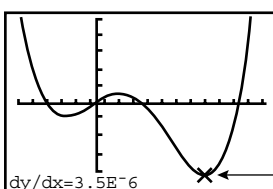

Horizontal tangent at (5, -43)

The command $\text{nDeriv}(Y_1, X, X)$ computes the value of the

derivative of function Y_1 in terms of x for all x .

Values of the derivative of $f(x)$ will be graphed as Y_2 , and the derivative function, $f'(x) = x^3 - \frac{9x^2}{2} - 4x + \frac{15}{2}$, determined by manual application of differentiation rules (part (i)), will be graphed as Y_3 . Note that the graph of Y_3 will be in bold style to distinguish it from Y_2 , and that the equation Y_1 has been turned 'off'.

```
Plot1 Plot2 Plot3
\Y1=X^4/4-(3X^3)/2-2X^2+15X/2+3/4
\Y2=nDeriv(Y1,X,X)
\Y3=X^3-(9X^2)/2-4X+15/2
```

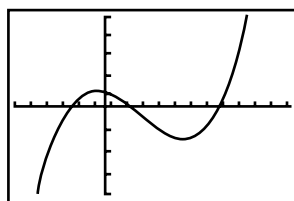

$$Y_2 = \text{nDeriv}(Y_1, X, X)$$

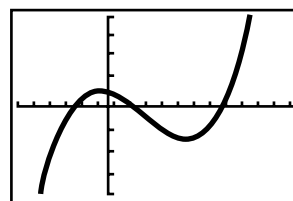

$$Y_3 = x^3 - \frac{9x^2}{2} - 4x + \frac{15}{2}$$

$$Y_1 = \frac{x^4}{4} - \frac{3x^3}{2} - 2x^2 + \frac{15x}{2} + \frac{3}{4}$$

Since the two graphs match, this confirms that the derivative found in part (i) using differentiation rules is correct.

Example 10

The curve $y = ax^3 + 7x^2 - 8x - 5$ has a turning point at the point where $x = -2$. Determine the value of a .

Solution

There must be a horizontal tangent, and a slope of zero, at the point where the graph has a turning point.

$$\begin{aligned} \frac{dy}{dx} &= \frac{d}{dx}(ax^3 + 7x^2 - 8x - 5) \\ &= a \frac{d}{dx}(x^3) + 7 \frac{d}{dx}(x^2) - 8 \frac{d}{dx}(x) + \frac{d}{dx}(-5) = 3ax^2 + 14x - 8 \end{aligned}$$

$$\begin{aligned} \frac{dy}{dx} &= 0 \text{ when } x = -2: 3a(-2)^2 + 14(-2) - 8 = 0 \\ &\Rightarrow 12a - 28 - 8 = 0 \Rightarrow 12a = 36 \Rightarrow a = 3 \end{aligned}$$

Recall that the derivative of a function is a formula for the **instantaneous rate of change** of the dependent variable (commonly y) with respect to the dependent variable (x). In other words, as illustrated earlier in this section, the slope of the tangent at a point gives the slope, or rate of change, of the curve at that point. The slope of a **secant line** (that crosses the curve at two points) gives the **average rate of change** between the two points.

Example 11

Boiling water is poured into a cup. The temperature of the water in degrees Celsius, C , after t minutes is given by $C = 19 + \frac{182}{t^{\frac{3}{2}}}$, for times $t \geq 1$ minute.

- Find the average rate of change of the temperature from $t = 2$ to $t = 6$.
- Find the rate of change of the temperature at the instant that $t = 4$.

Solution

a)

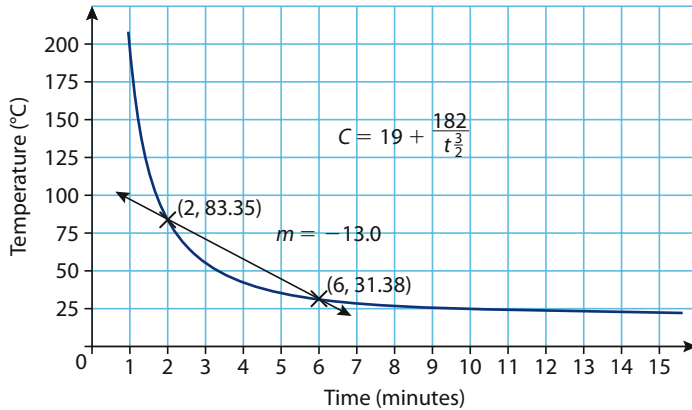

When $t = 2$, $C \approx 83.35^\circ$ and when $t = 6$, $C \approx 31.38^\circ$. The average rate of change from $t = 2$ to $t = 6$ is the slope of the line through the points $(2, 83.35)$ and $(6, 31.38)$.

$$\text{Average rate of change} = \frac{83.35 - 31.38}{2 - 6} = \frac{51.97}{-4} = -12.9925.$$

To an accuracy of 3 significant figures, the average rate of change from $t = 2$ to $t = 6$ is -13.0°C per minute. During that period of time the water is, on average, becoming 13 degrees cooler every minute.

- Let's compute the derivative $\frac{dC}{dt}$, i.e. the rate of change of degrees C with respect to time t , from which we can compute the rate the temperature is changing at the moment when $t = 4$.

$$\frac{dC}{dt} = \frac{d}{dt} \left(19 + \frac{182}{t^{\frac{3}{2}}} \right) = \frac{d}{dt} (19 + 182t^{-\frac{3}{2}}) = \frac{d}{dt} (19) + 182 \frac{d}{dt} (t^{-\frac{3}{2}})$$

$$= 0 + 182 \left(-\frac{3}{2} t^{-\frac{3}{2}-1} \right) = -273t^{-\frac{5}{2}}$$

$$\frac{dC}{dt} = -\frac{273}{t^{\frac{5}{2}}} = -\frac{273}{\sqrt{t^5}}$$

At $t = 4$:

$$\frac{dC}{dt} = -\frac{273}{\sqrt{4^5}} = -\frac{273}{32} \approx -8.53$$

Therefore, the temperature's instantaneous rate of change at $t = 4$ minutes is -8.53°C per minute.

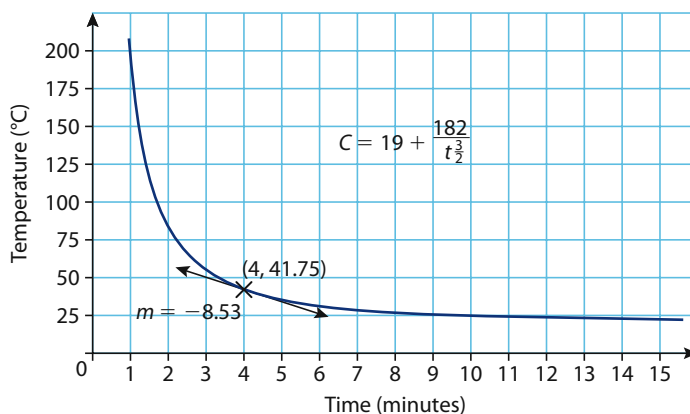

Differentiating $\sin x$ and $\cos x$ using limit definition for derivative

To add to our growing list of differentiation rules, we will now determine the derivatives for the sine and cosine functions. The results will help us determine the derivatives for the other trigonometric functions in Chapter 15.

The rigorous analytical method (applying limit definition of derivative) for finding these two derivatives requires two limit results that we found by decidedly non-rigorous methods in Example 2 in the previous section; namely that $\lim_{x \rightarrow 0} \frac{\sin x}{x} = 1$ and $\lim_{x \rightarrow 0} \frac{\cos x - 1}{x} = 0$. We conjectured the value of these limits after exploring the behaviour of the expressions on our GDC. Example 5 illustrated that estimating limits by such informal methods is not foolproof. Hence, we will now put these two limit results on firmer ground through a more rigorous approach.

We first state, without proof, an important theorem in mathematics.

The squeeze theorem

If $g(x) \leq f(x) \leq h(x)$ for all $x \neq c$ in some interval about c , and

$$\lim_{x \rightarrow c} g(x) = \lim_{x \rightarrow c} h(x) = L,$$

then

$$\lim_{x \rightarrow c} f(x) = L.$$

Figure 13.13 Squeezing f between g and h forces the limiting value of f to be between the limiting values of g and h .

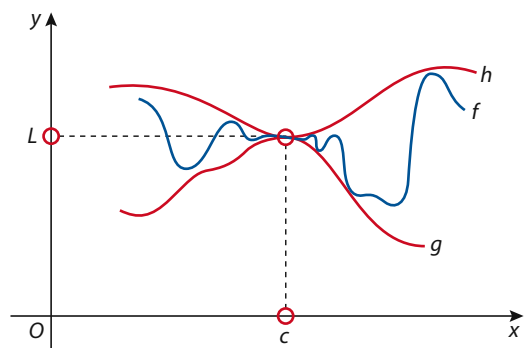

The theorem describes a function f whose values are 'squeezed' between the values of two other functions, g and h . If g and h have the same limit as $x \rightarrow c$, then f has the same limit, as suggested by Figure 13.13.

Consider a sector of a circle with centre O , central angle θ (in radian measure) and radius 1 (see Figure 13.14). Further consider right triangle AOC , sector AOB and triangle AOB . We know that point B has coordinates $(\cos \theta, \sin \theta)$ and point C has coordinates $(1, \tan \theta)$. From Section 7.1, we also know that the area of a sector with central angle θ is $\frac{1}{2}r^2\theta$. It is clear that the area of sector AOB must be between the area of $\triangle AOC$ and the area of $\triangle AOB$, that is, the sector is 'squeezed' between the two triangles (Figure 13.15).

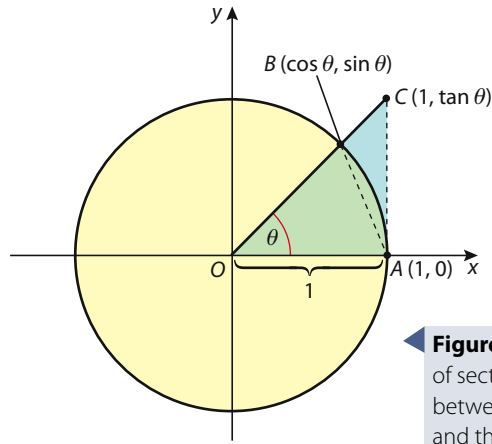

Figure 13.14 Area of sector AOB must be between the area of $\triangle AOC$ and the area of $\triangle AOB$.

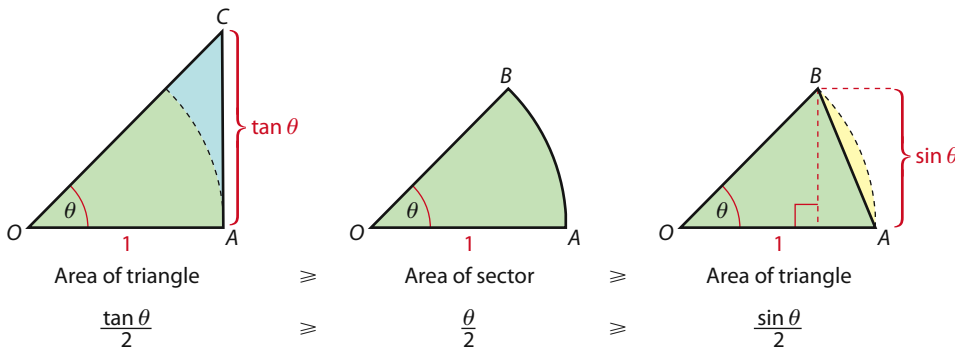

Figure 13.15 Area of sector AOB is squeezed between the two triangles.

Multiplying all the area expressions by $\frac{2}{\sin \theta}$ gives

$$\frac{1}{\cos \theta} \geq \frac{\theta}{\sin \theta} \geq 1.$$

Given the fact that if $\frac{a}{b} > \frac{c}{d}$ then $\frac{b}{a} < \frac{d}{c}$, we can write the reciprocals of the three expressions and reverse the inequality signs. This gives

$$\cos \theta \leq \frac{\sin \theta}{\theta} \leq 1.$$

It follows that

$$\lim_{\theta \rightarrow 0} \cos \theta \leq \lim_{\theta \rightarrow 0} \frac{\sin \theta}{\theta} \leq \lim_{\theta \rightarrow 0} 1.$$

From direct substitution, $\lim_{\theta \rightarrow 0} \cos \theta = 1$. Thus,

$$1 \leq \lim_{\theta \rightarrow 0} \frac{\sin \theta}{\theta} \leq 1.$$

We can now apply the squeeze theorem and conclude that $\lim_{\theta \rightarrow 0} \frac{\sin \theta}{\theta} = 1$.

Furthermore, because $\cos(-\theta) = \cos \theta$ and $\frac{\sin(-\theta)}{-\theta} = \frac{\sin(\theta)}{\theta}$, we can also conclude that this limit is true for all non-zero values of θ in the interval $-\frac{\pi}{2} < \theta < \frac{\pi}{2}$.

The above result, $\lim_{x \rightarrow 0} \frac{\sin x}{x} = 1$, can be used to algebraically deduce that $\lim_{x \rightarrow 0} \frac{\cos x - 1}{x} = 0$. This is saved for you to do in Exercise 13.2, question 26.

Example 12

Differentiate from first principles:

a) $f(x) = \sin x$ b) $f(x) = \cos x$

Solution

For both of the derivatives we will need to make use of a compound angle identity and the limit results $\lim_{x \rightarrow 0} \frac{\sin x}{x} = 1$ and $\lim_{x \rightarrow 0} \frac{\cos x - 1}{x} = 0$.

a) We start by substituting into the limit definition for the derivative.

$$f'(x) = \lim_{h \rightarrow 0} \frac{f(x+h) - f(x)}{h} = \lim_{h \rightarrow 0} \frac{\sin(x+h) - \sin x}{h}$$

Applying $\sin(A+B) = \sin A \cos B + \cos A \sin B$.
$$= \lim_{h \rightarrow 0} \frac{\sin x \cos h + \cos x \sin h - \sin x}{h}$$

Splitting argument into two fractions.
$$= \lim_{h \rightarrow 0} \left[\frac{\sin x \cos h - \sin x}{h} + \frac{\cos x \sin h}{h} \right]$$

Factorizing common factors in each fraction.
$$= \lim_{h \rightarrow 0} \left[\sin x \left(\frac{\cos h - 1}{h} \right) + \cos x \left(\frac{\sin h}{h} \right) \right]$$

Applying $\lim_{x \rightarrow a} [f(x) \cdot g(x)] = L \cdot K$.
$$= \lim_{h \rightarrow 0} \sin x \cdot \lim_{h \rightarrow 0} \left(\frac{\cos h - 1}{h} \right) + \lim_{h \rightarrow 0} \cos x \cdot \lim_{h \rightarrow 0} \left(\frac{\sin h}{h} \right)$$

Applying $\lim_{x \rightarrow 0} \frac{\sin x}{x} = 1$ and $\lim_{x \rightarrow 0} \frac{\cos x - 1}{x} = 0$.
$$= \sin x \cdot 0 + \cos x \cdot 1$$

$$= \cos x$$

Thus, if $f(x) = \sin x$ then $f'(x) = \cos x$, or using Leibniz notation

$$\frac{d}{dx}(\sin x) = \cos x.$$

b) Again, we start by substituting into the limit definition for the derivative.

$$f'(x) = \lim_{h \rightarrow 0} \frac{f(x+h) - f(x)}{h} = \lim_{h \rightarrow 0} \frac{\cos(x+h) - \cos x}{h}$$

Applying $\cos(A+B) = \cos A \cos B - \sin A \sin B$.
$$= \lim_{h \rightarrow 0} \frac{\cos x \cos h - \sin x \sin h - \cos x}{h}$$

Splitting argument into two fractions.
$$= \lim_{h \rightarrow 0} \left[\frac{\cos x \cos h - \cos x}{h} - \frac{\sin x \sin h}{h} \right]$$

Factorizing common factors in each fraction.
$$= \lim_{h \rightarrow 0} \left[\cos x \left(\frac{\cos h - 1}{h} \right) - \sin x \left(\frac{\sin h}{h} \right) \right]$$

Applying $\lim_{x \rightarrow a} [f(x) \cdot g(x)] = L \cdot K$.
$$= \lim_{h \rightarrow 0} \cos x \cdot \lim_{h \rightarrow 0} \left(\frac{\cos h - 1}{h} \right) - \lim_{h \rightarrow 0} \sin x \cdot \lim_{h \rightarrow 0} \left(\frac{\sin h}{h} \right)$$

Applying $\lim_{x \rightarrow 0} \frac{\sin x}{x} = 1$ and $\lim_{x \rightarrow 0} \frac{\cos x - 1}{x} = 0$.
$$= \cos x \cdot 0 - \sin x \cdot 1$$

$$= -\sin x$$

Thus, if $f(x) = \cos x$ then $f'(x) = -\sin x$, or using Leibniz notation

$$\frac{d}{dx}(\cos x) = -\sin x.$$

We will confirm these two results graphically at the start of Chapter 15.

Exercise 13.2

In questions 1–4, find the derivative of the function by applying the limit definition

$$f'(x) = \lim_{h \rightarrow 0} \frac{f(x+h) - f(x)}{h}.$$

1 $f(x) = 1 - x^2$

2 $g(x) = x^3 + 2$

3 $h(x) = \sqrt{x}$

4 $r(x) = \frac{1}{x^2}$

5 Using your results from questions 1–4, find the slope of the graph of each function in 1–4 at the point where $x = 1$. Sketch each function and draw a line tangent to the graph at $x = 1$.

In questions 6–12, a) find the derivative of the function, and b) compute the slope of the graph of the function at the indicated point. Use a GDC to confirm your results.

6 $y = 3x^2 - 4x$ point (0, 0)

7 $y = 1 - 6x - x^2$ point (-3, 10)

8 $y = \frac{2}{x^3}$ point (-1, 2)

9 $y = x^5 - x^3 - x$ point (1, -1)

10 $y = (x+2)(x-6)$ point (2, -16)

11 $y = 2x + \frac{1}{x} - \frac{3}{x^3}$ point (1, 0)

12 $y = \frac{x^3 + 1}{x^2}$ point (-1, 0)

13 The slope of the curve $y = x^2 + ax + b$ at the point (2, -4) is -1. Find the value of a and the value of b .

In questions 14–17, find the coordinates of any points on the graph of the function where the slope is equal to the given value.

14 $y = x^2 + 3x$ slope = 3

15 $y = x^3$ slope = 12

16 $y = x^2 - 5x + 1$ slope = 0

17 $y = x^2 - 3x$ slope = -1

18 Use the graph of f to answer each of the following questions.

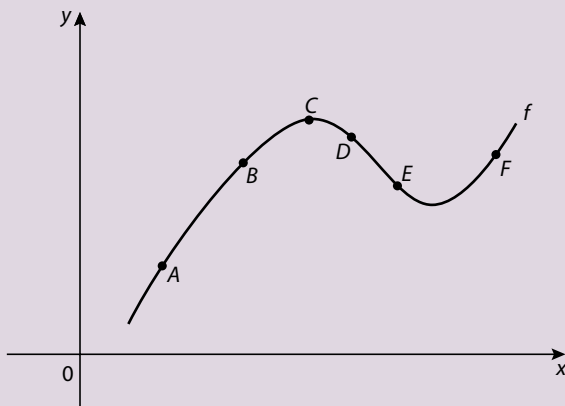

- a) Between which two consecutive points is the average rate of change of the function greatest?
- b) At what points is the instantaneous rate of change of f positive, negative and zero?
- c) For which two pairs of points is the average rate of change approximately equal?
- 19** The slope of the curve $y = x^2 - 4x + 6$ at the point $(3, 3)$ is equal to the slope of the curve $y = 8x - 3x^2$ at (a, b) . Find the value of a and the value of b .
- 20** The graph of the equation $y = ax^3 - 2x^2 - x + 7$ has a slope of 3 at the point where $x = 2$. Find the value of a .
- 21** Find the coordinates of the point on the graph of $y = x^2 - x$ at which the tangent is parallel to the line $y = 5x$.
- 22** Let $f(x) = x^3 + 1$.
- a) Evaluate $\frac{f(2+h) - f(2)}{h}$ for $h = 0.1$.
- b) What number does $\frac{f(2+h) - f(2)}{h}$ approach as h approaches zero?
- 23** From first principles, find the derivative for the general quadratic function, $f(x) = ax^2 + bx + c$. Confirm your result by checking that it produces:
- (i) the derivative of x^2 when $a = 1, b = 0, c = 0$
- (ii) the derivative of $3x^2 - 4x + 2$ when $a = 3, b = -4, c = 2$.
- 24** A car is parked with the windows and doors closed for five hours. The temperature inside the car in degrees Celsius, C , is given by $C = 2\sqrt{t^3} + 17$ with t representing the number of hours since the car was first parked.
- a) Find the average rate of change of the temperature from $t = 1$ to $t = 4$.
- b) Find the function that gives the instantaneous rate of change of the temperature for any time $t, 0 < t < 5$.
- c) Find the time t at which the instantaneous rate of change of the temperature is equal to the average rate of change from $t = 1$ to $t = 4$.
- 25** A function f is even if $f(-x) = f(x)$ and a function g is odd if $g(-x) = -g(x)$.
- a) If the function h is even, prove that the derivative of h is odd. In other words, if $h(-x) = h(x)$, then, $h'(-x) = -h'(x)$.
- b) If the function p is odd, prove that the derivative of h is even. In other words, if $p(-x) = -p(x)$, then, $p'(-x) = p'(x)$.
- 26** Using algebraic manipulation and the proven result $\lim_{x \rightarrow 0} \frac{\sin x}{x} = 1$, prove that $\lim_{x \rightarrow 0} \frac{\cos x - 1}{x} = 0$.

In questions 27–30, find the indicated derivative by applying the limit definition of the derivative (i.e. by first principles). (See questions 20 and 21 in Exercise 13.1 for 27 and 28 below.)

27 $\frac{d}{dx}(\sqrt{x})$

28 $\frac{d}{dx}\left(\frac{1}{x}\right)$

29 $\frac{d}{dx}\left(\frac{2+x}{3-x}\right)$

30 $\frac{d}{dx}\left(\frac{1}{\sqrt{x+2}}\right)$

- 31** Prove the constant rule by first principles. That is, prove that given a constant $c, c \in \mathbb{R}, \frac{d}{dx}(c) = 0$.

13.3

Maxima and minima – first and second derivatives

The relationship between a function and its derivative

The derivative, written in Newton notation as $f'(x)$ or in Leibniz notation as $\frac{dy}{dx}$, is a function derived from a function f that gives the slope of the graph of f at any x in the function's domain (given that the curve is 'smooth' at the value of x). The derivative is a slope, or rate of change, function. Knowing the slope of a function at different values in its domain tells us about properties of the function and the shape of its graph.

In the previous section, we observed that if a graph 'turns' at a particular point (for example, at the vertex of a parabola), then it has a horizontal tangent (slope = 0) at the point. Hence, the derivative will equal zero at a 'turning point'. In Section 3.2, we found the vertex of the graph of a quadratic function by using the technique of completing the square to write its equation in vertex form. We can also find the vertex by means of differentiation. As we look at the graph of a parabola moving from left to right (i.e. domain values increasing), it either turns from going down to going up (decreasing to increasing), or from going up to going down (increasing to decreasing) (Figure 13.16).

Example 13

Using differentiation, find the vertex of the parabola with the equation $y = x^2 - 8x + 14$.

Solution

Find the value of x for which the derivative, $\frac{dy}{dx}$, is zero.

$$\frac{dy}{dx} = \frac{d}{dx}(x^2 - 8x + 14) = 2x - 8 = 0 \Rightarrow x = 4$$

Thus, the x -coordinate of the vertex is 4.

To find the y -coordinate of the vertex, we substitute $x = 4$ into the equation, giving $y = 4^2 - 8(4) + 14 = -2$. Therefore, the vertex has coordinates $(4, -2)$.

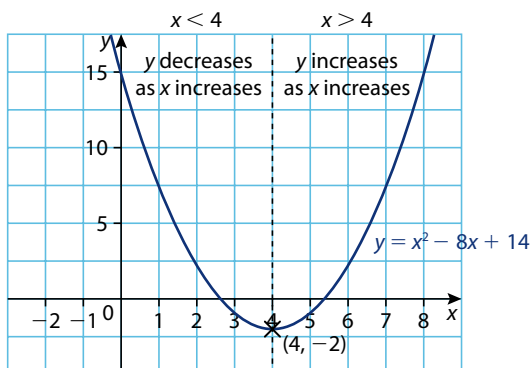

If the graph of a function is 'smooth' at a particular point, the function is considered to be *differentiable* at this point. In other words, a tangent line exists at this point. All functions that will be differentiated in this course will be differentiable at all values in the function's domain.

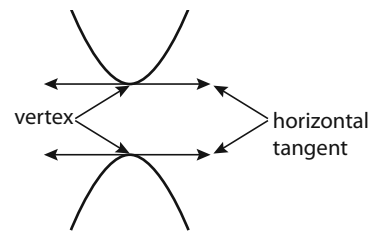

Figure 13.16

Figure 13.17 Slope changes from negative to positive as x increases.

We know that the parabola in Example 13 will ‘open up’ because the coefficient of the quadratic term, x^2 , is positive. The parabola has a negative slope (decreasing) to the left of the vertex and a positive slope (increasing) to the right of the vertex (Figure 13.17). As the values of x increase, the derivative of $y = x^2 - 8x + 14$ will change from negative to zero to positive, accordingly.

$$\frac{dy}{dx} = 2x - 8 \Rightarrow \frac{dy}{dx} < 0 \text{ for } x < 4 \text{ and } \frac{dy}{dx} = 0 \text{ for } x = 4 \text{ and } \frac{dy}{dx} > 0 \text{ for } x > 4$$

In other words, the function $f(x) = x^2 - 8x + 14$ is decreasing for all $x < 4$; it is neither decreasing nor increasing at $x = 4$; and it is increasing for all $x > 4$. A point at which a function is neither increasing nor decreasing (i.e. there is a horizontal tangent) is called a **stationary point**.

A convenient way to demonstrate where a function is increasing or decreasing and the location of any stationary points is with a **sign chart** for the function and its derivative, as shown in Figure 13.18 for $f(x) = x^2 - 8x + 14$. The derivative $f'(x) = 2x - 8$ is zero only at $x = 4$, thereby dividing the domain of f (i.e. \mathbb{R}) into two intervals: $x < 4$ and $x > 4$. $f'(x) = 2x - 8$ is a **continuous** function (i.e. no ‘gaps’ in the domain) so it is only necessary to test one point in each interval in order to determine the sign of all the values of the derivative in that interval. $f'(x)$ can only change sign at $x = 4$. For example, the fact that $f'(3) = 2(3) - 8 = -2 < 0$ means that $f'(x) < 0$ for all x when $x < 4$. Therefore, f is decreasing for all x in the open interval $(-\infty, 4)$.

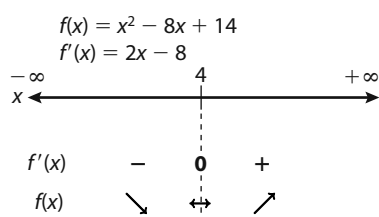

Figure 13.18 Sign chart for $f'(x)$ and $f(x)$.

Geometrically speaking, a function is **continuous** if there is no break in its graph; and a function is **differentiable** (i.e. a derivative exists) at any points where it is ‘smooth’.



Increasing and decreasing functions and stationary points

If $f'(x) > 0$ for $a < x < b$, then $f(x)$ is **increasing** on the interval $a < x < b$.

If $f'(x) < 0$ for $a < x < b$, then $f(x)$ is **decreasing** on the interval $a < x < b$.

If $f'(x) = 0$ for $a < x < b$, then $f(x)$ is **constant** on the interval $a < x < b$.

If $f'(x) = 0$ for a single value $x = c$ on some interval $a < c < b$, then $f(x)$ has a **stationary point** at $x = c$. The corresponding point $(c, f(c))$ on the graph of f is called a stationary point.

It is at stationary points, or endpoints of the domain if the domain is not all real numbers, where a function may have a maximum or minimum value. These points at which extreme values of a function *may* occur are often referred to as **critical points**. Whether a function is increasing or decreasing on either side of a stationary point will indicate whether the stationary point is a maximum, minimum or neither.

Example 14

Consider the function $f(x) = 2x^3 + 3x^2 - 12x - 4$, $x \in \mathbb{R}$.

- Find any stationary points of f .
- Using the derivative of f , classify any stationary points as a maximum or minimum.

Solution

$$\begin{aligned} \text{a) } f'(x) &= 6x^2 + 6x - 12 = 0 \Rightarrow 6(x^2 + x - 2) = 0 \\ &\Rightarrow 6(x + 2)(x - 1) = 0 \Rightarrow x = -2 \text{ or } x = 1 \end{aligned}$$

With a domain of all real numbers there are no domain endpoints that may be an extreme value. Thus, f has two critical points: one at $x = -2$ and the other at $x = 1$.

When $x = -2$: $y = 2(-2)^3 + 3(-2)^2 - 12(-2) - 4 = 16 \Rightarrow f$ has a stationary point at $(-2, 16)$.

When $x = 1$: $y = 2(1)^3 + 3(1)^2 - 12(1) - 4 = -11 \Rightarrow f$ has a stationary point at $(1, -11)$.

- b) Construct a sign chart for $f'(x)$ and $f(x)$ (left) to show where f is increasing or decreasing. The derivative $f'(x)$ has two zeros, at $x = -2$ and $x = 1$, thereby dividing the domain of f into three intervals that need to be tested. Since $f'(-3) = 6(-1)(-4) = 24 > 0$, then $f'(x) > 0$ for all $x < -2$. Likewise, since $f'(2) = 6(4)(1) = 24 > 0$, then $f'(x) > 0$ for all $x > 1$. Thus, f is increasing on the open intervals $(-\infty, -2)$ and $(1, \infty)$. Since $f'(0) = -12 < 0$, then $f'(x) < 0$ for all x such that $-2 < x < 1$. Thus, f is decreasing on the open interval $(-2, 1)$, i.e. $-2 < x < 1$. From this information, we can visualize for increasing values of x that the graph of f is going up for all $x < -2$, then turning down at $x = -2$, then going down for values of x from -2 to 1 , then turning up at $x = 1$, and then going up for all $x > 1$. The basic shape of the graph of f will look something like the rough sketch shown left. Clearly, the stationary point $(-2, 16)$ is a maximum and the stationary point $(1, -11)$ is a minimum.

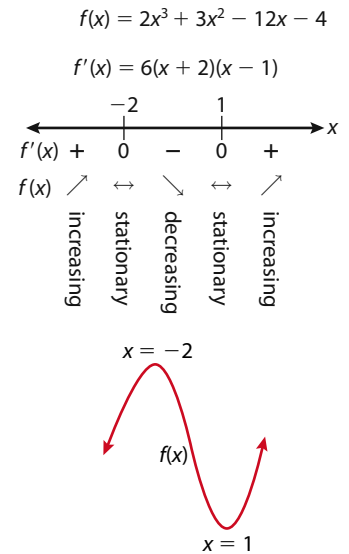

The graph of $f(x) = 2x^3 + 3x^2 - 12x - 4$ from Example 14 (Figure 13.19) visually confirms the results acquired from analyzing the derivative of f .

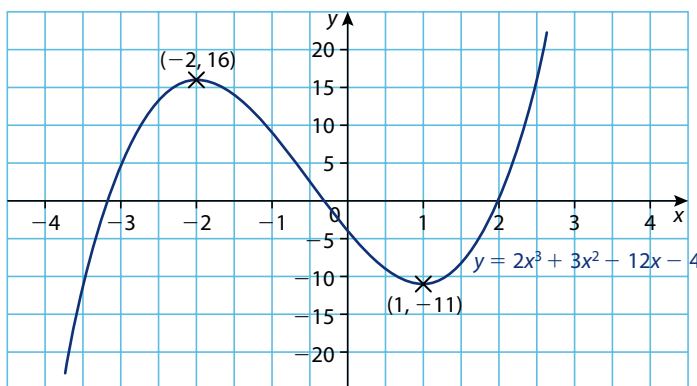

For Example 14, we can express the result for part b) most clearly by saying that $f(x)$ has a **relative maximum** value of 16 at $x = -2$, and $f(x)$ has a **relative minimum** value of -11 at $x = 1$. The reason that these *extreme* values are described as ‘relative’ (sometimes described as ‘local’) is because

Figure 3.19



The plural of ‘maximum’ is ‘maxima’, and the plural of ‘minimum’ is ‘minima’. Maxima and minima are collectively referred to as ‘extrema’ – the plural of ‘extremum’ (extreme value). Extrema of a function that do not occur at domain endpoints will be ‘turning points’ of the graph of the function.

they are a maximum or minimum for the function in the immediate vicinity of the point, but not for the entire domain of the function. A point that is a maximum/minimum for the entire domain is called an **absolute**, or **global, maximum/minimum**.

The first derivative test

From Example 14, we can see that a function f has a maximum at some $x = c$ if $f'(c) = 0$ and f is *increasing* immediately to the left of $x = c$ and *decreasing* immediately to the right of $x = c$. Similarly, f has a minimum at some $x = c$ if $f'(c) = 0$ and f is *decreasing* immediately to the left of $x = c$ and *increasing* immediately to the right of $x = c$. It is important to understand, however, that not all stationary points are either a maximum or minimum.

Example 15

For the function $f(x) = x^4 - 2x^3$, find all stationary points and describe them completely.

Solution

$$f'(x) = \frac{d}{dx}(x^4 - 2x^3) = 4x^3 - 6x^2 = 0 \Rightarrow 2x^2(2x - 3) = 0$$

$$\Rightarrow x = 0 \text{ or } x = \frac{3}{2}$$

The implied domain is all real numbers, so $x = 0$ and $x = \frac{3}{2}$ are the critical points of f .

When $x = 0$, $y = f(0) = 0$.

$$\text{When } x = \frac{3}{2}, y = f\left(\frac{3}{2}\right) = \left(\frac{3}{2}\right)^4 - 2\left(\frac{3}{2}\right)^3 = \frac{81}{16} - \frac{54}{8} = -\frac{27}{16}.$$

Therefore, f has stationary points at $(0, 0)$ and $\left(\frac{3}{2}, -\frac{27}{16}\right)$.

Because f has two stationary points, there are three intervals for which to test the sign of the derivative. We could use some form of a sign chart as shown previously, or we can use a more detailed table that summarizes the testing of the three intervals and the two critical points as shown below.

Interval/point	$x < 0$	$x = 0$	$0 < x < \frac{3}{2}$	$x = \frac{3}{2}$	$x > \frac{3}{2}$
Test value	$x = -1$		$x = 1$		$x = 2$
Sign of $f'(x)$	$f'(-1) = -10 < 0$	0	$f'(1) = -2 < 0$	0	$f'(2) = 8 > 0$
Conclusion	f decreasing ↘	none	f decreasing ↘	abs. min.	f increasing ↗

On either side of $x = 0$, f does not change from either decreasing to increasing or from increasing to decreasing. Although there is a horizontal tangent at $(0, 0)$, it is *not* an extreme value (turning point). The function steadily decreases as x approaches zero, then at $x = 0$ the function has a rate of change (slope) of zero for an instant and then continues on decreasing. As x approaches $\frac{3}{2}$, f is decreasing and then switches to increasing at $x = \frac{3}{2}$.

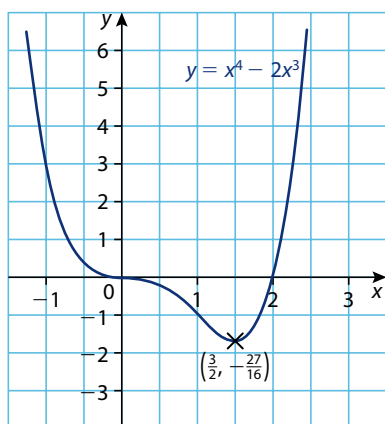

Therefore, the stationary point $(0, 0)$ is neither a maximum nor a minimum; and the stationary point $\left(\frac{3}{2}, -\frac{27}{16}\right)$ is an absolute minimum. Or, in other words, f has an absolute (global) minimum value of $-\frac{27}{16}$ at $x = \frac{3}{2}$.

The reason that an *absolute*, rather than a *relative*, minimum value occurs at $x = \frac{3}{2}$ is because for all $x < \frac{3}{2}$ the function f is either decreasing or constant (at $x = 0$) and for all $x > \frac{3}{2}$ f is increasing.

First derivative test for maxima and minima of a function

Suppose that $x = c$ is a critical point of a continuous and smooth function f . That is, $f'(c) = 0$ and $x = c$ is a stationary point or $x = c$ is an endpoint of the domain.

I. At a stationary point $x = c$:

1. If $f'(x)$ changes sign from positive to negative as x increases through $x = c$, then f has a relative maximum at $x = c$.

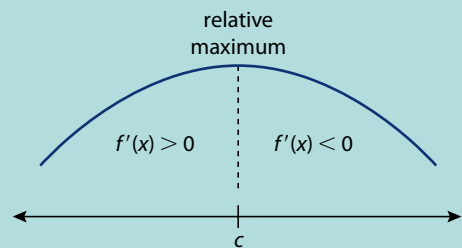

2. If $f'(x)$ changes sign from negative to positive as x increases through $x = c$, then f has a relative minimum at $x = c$.

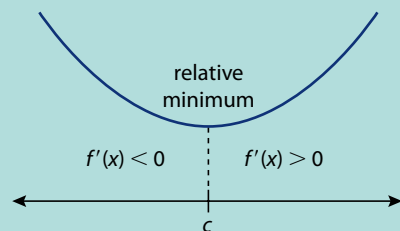

3. If $f'(x)$ does not change sign as x increases through $x = c$, then f has neither a relative maximum nor a relative minimum at $x = c$.

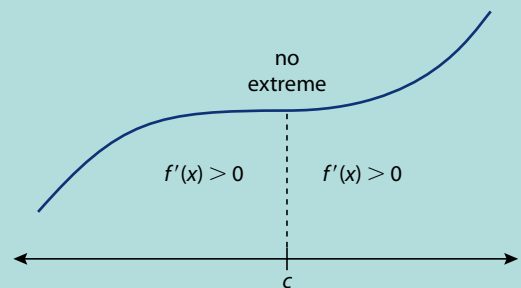

II. At a domain endpoint $x = c$:

If $x = c$ is an endpoint of the domain, then $x = c$ will be a relative maximum or minimum of f if the sign of $f'(x)$ is always positive or always negative for $x > c$ (at a left endpoint), or for $x < c$ (at a right endpoint), as illustrated below.

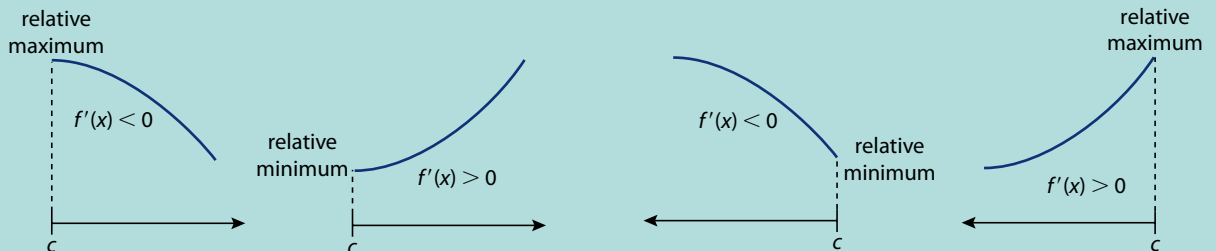

If it is possible to show that a relative maximum/minimum at $x = c$ is the greatest/least value for the entire domain of f , then it is classified as an absolute maximum/minimum.

Example 16

Apply the first derivative test to find any local extreme values for $f(x)$. Identify any absolute extrema.

$$f(x) = 4x^3 - 9x^2 - 120x + 25$$

Solution

$$f'(x) = \frac{d}{dx}(4x^3 - 9x^2 - 120x + 25) = 12x^2 - 18x - 120$$

$$\begin{aligned} f'(x) = 12x^2 - 18x - 120 = 0 &\Rightarrow 6(2x^2 - 3x - 20) = 0 \\ &\Rightarrow 6(2x + 5)(x - 4) = 0 \end{aligned}$$

Thus, f has stationary points at $x = -\frac{5}{2}$ and $x = 4$.

To classify the stationary point at $x = -\frac{5}{2}$, we need to choose test points on either side of $-\frac{5}{2}$, for example, $x = -3$ (left) and $x = 0$ (right). Then we have

$$f'(-3) = 6(-1)(-7) = 42 > 0$$

$$f'(0) = 6(5)(-4) = -120 < 0$$

So f has a relative maximum at $x = -\frac{5}{2}$.

$$f\left(-\frac{5}{2}\right) = 4\left(-\frac{5}{2}\right)^3 - 9\left(-\frac{5}{2}\right)^2 - 120\left(-\frac{5}{2}\right) + 25 = 206.25$$

Therefore, f has a relative maximum value of 206.25 at $x = -\frac{5}{2}$.

To classify the stationary point at $x = 4$, we need to choose test points on either side of 4, for example, $x = 0$ (left) and $x = 5$ (right). Then we have

$$f'(0) = -120 < 0$$

$$f'(5) = 6(15)(1) = 90 > 0$$

So f has a relative minimum at $x = 4$.

$$f(4) = 4(4)^3 - 9(4)^2 - 120(4) + 25 = -343$$

Therefore, f has a relative minimum value of -343 at $x = 4$.

Change in displacement and velocity

Consider the motion of an object such that we know its position s relative to a reference point or line as a function of time t given by $s(t)$. The **displacement** of the object over the time interval from t_1 to t_2 is:

$$\text{change in } s = \text{displacement} = s(t_2) - s(t_1)$$

The **average velocity** of the object over the time interval is:

$$v_{\text{avg}} = \frac{\text{displacement}}{\text{change in time}} = \frac{s(t_2) - s(t_1)}{t_2 - t_1}$$

The object's **instantaneous velocity** at a particular time, t , is the value of the derivative of the position function, s , with respect to time at t .

$$\text{velocity} = \frac{ds}{dt} = s'(t)$$

Example 17

A rocket is launched upwards into the air. Its vertical position, s metres, above the ground at t seconds is given by

$$s(t) = -5t^2 + 18t + 1.$$

- Find the average velocity over the time interval from $t = 1$ second to $t = 2$ seconds.
- Find the instantaneous velocity at $t = 1$ second.
- Find the maximum height reached by the rocket and the time at which this occurs.



Solution

$$\begin{aligned} \text{a) } v_{\text{avg}} &= \frac{s(2) - s(1)}{2 - 1} = \frac{[-5(2)^2 + 18(2) + 1] - [-5 + 18 + 1]}{1} \\ &= 3 \text{ metres per second (or } \text{m s}^{-1}\text{)} \end{aligned}$$

$$\text{b) } s'(t) = -10t + 18 \Rightarrow s'(1) = -10 + 18 = 8 \text{ m s}^{-1}$$

$$\text{c) } s'(t) = -10t + 18 = 0 \Rightarrow t = 1.8$$

Thus, s has a stationary point at $t = 1.8$. t must be positive and ranges from time of launch ($t = 0$) to when the rocket hits the ground, i.e. $h = 0$.

$$\begin{aligned} s(t) = -5t^2 + 18t + 1 = 0 &\Rightarrow t = \frac{-18 \pm \sqrt{18^2 - 4(-5)(1)}}{2(-5)} \\ &\Rightarrow t \approx \cancel{-0.5472} \text{ or } t \approx 3.655 \end{aligned}$$

So, the rocket hits the ground about 3.66 seconds after the time of launch. Hence, the domain for the position (s) and velocity (v) functions is $0 \leq t \leq 3.66$. Therefore, the function s has three critical points: $t = 0$, $t = 1.8$ and $t \approx 3.66$.

The maximum of the function, i.e. the maximum height, most likely occurs at the critical point $t = 1.8$. Let's confirm this.

Applying the first derivative test, we determine the sign of the derivative, $s'(t)$, for values on either side of $t = 1.8$, for example, $t = 0$ and $t = 2$. $s'(0) = 18 > 0$ and $s'(2) = -2 < 0$. Neither of the domain endpoints, $t = 0$ and $t \approx 3.66$, are at a maximum or minimum because the function is not constantly increasing or constantly decreasing before or after the endpoint. Since the function changes from increasing to decreasing at $t = 1.8$ and $s(1.8) = -5(1.8)^2 + 18(1.8) + 1 = 17.2$, then the rocket reaches a maximum height of 17.2 metres 1.8 seconds after it was launched.

The relationship between a function and its second derivative

You may have wondered why the strategy we are applying to locate and classify extrema for a function focuses on using the *first* derivative of the function. This implies that we are interested in using some other type of derivative, namely the *second* derivative. There is another useful test for the purpose of analyzing the stationary point of a function that makes use of the derivative of the derivative, i.e. the second derivative, of the function.

When we differentiate a function $y = f(x)$, we obtain the first derivative $f'(x)$ (also denoted as $\frac{dy}{dx}$). Often this is a function that can also be differentiated. The result of doing so is the derivative of $f'(x)$, which is denoted in Newton notation as $f''(x)$ or in Leibniz notation as $\frac{d^2y}{dx^2}$ and called the second derivative of f with respect to x . For example, if $f(x) = x^3$, then $f'(x) = 3x^2$ and $f''(x) = 6x$.

Second derivatives, like first derivatives, occur often in methods of applying calculus. In Example 17, the function $s(t)$ gave the position, in metres above the ground, of a projectile (toy rocket) where t , in seconds, is the time since the projectile was launched. The function $s'(t)$, the first derivative of the position function, then gives the rate of change of the object's position, i.e. its velocity, in metres per second (m s^{-1}). Differentiation of this function gives the rate of change of the object's velocity, i.e. its *acceleration*, measured in metres per second per second (m s^{-2}).

The graphs of the position, velocity and acceleration functions for Example 17 aligned vertically (Figure 13.20) nicely illustrate the relationships between a function, its first derivative and its second derivative. The slope of the graph of $s(t)$ is initially a large positive value (graph is steep), but steadily decreases until it is zero (horizontal tangent) at $t = 1.8$ and then continues to decrease, becoming a large negative value (again, steep, but in the other direction). This corresponds to the real-life situation in which the rocket is launched with a high initial velocity ($v(0) = 18 \text{ m s}^{-1}$) and then its velocity decreases steadily due to gravity. The rocket's velocity is zero for just an instant when it reaches its maximum height at $t = 1.8$ and then its velocity becomes more and more negative because it has changed direction and is moving back (negative direction) to the ground. The rate of change of the velocity, $v'(t)$, is constant and it is negative because the velocity is decreasing from positive values to zero to negative values. This is clear from the fact that the graph of the velocity function, $v(t)$, is a straight line with a negative slope. It follows then that the acceleration function – the rate of change of velocity – is a negative constant, $a = -10$ in this case, and its graph is a horizontal line.

In Example 17, it is not possible to have a negative function value for $s(t)$ because the rocket's position is always above, or at, ground level. In many motion problems in calculus, we consider a simplified version by limiting

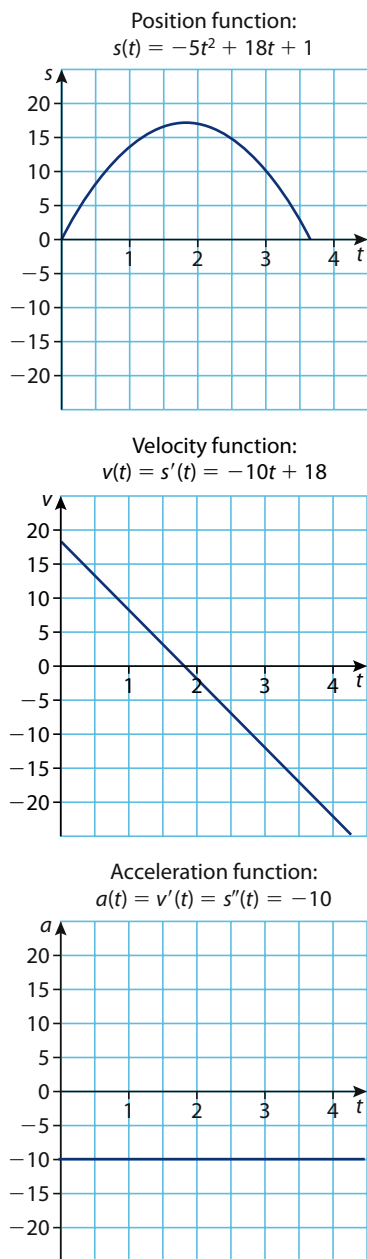

Figure 13.20 Position, velocity and acceleration functions for rocket.

an object's motion to a line with its position given as its **displacement** from a fixed point (usually the origin). At a position left of the fixed point, the object's displacement is negative, and at a position right of the fixed point, the displacement is positive. Velocity can also be positive or negative depending on the direction of travel (i.e. the sign of the rate of change of the object's displacement). Likewise, acceleration is positive if velocity is increasing (i.e. rate of change of velocity is positive) and negative if velocity is decreasing.

A common misconception is that acceleration is positive for motion in the positive direction (usually 'right' or 'up') and negative for motion in the negative direction (usually 'left' or 'down'). Acceleration indicates how velocity is changing. Even though an object may be moving in a positive direction (e.g. to the right) if it is slowing down, then its acceleration is acting in the opposite direction and would be negative. In Example 17, the rocket was always accelerating in the negative direction, -10 m s^{-2} , due to the force of gravity. Note: A more accurate value for the acceleration of a free-falling object due to gravity is -9.8 m s^{-2} .

Motion along a line

If an object moves in a straight line such that at time t its displacement (position) from a fixed point is $s(t)$, then the first derivative $s'(t)$, also written as $\frac{ds}{dt}$, gives the velocity $v(t)$ at time t .

The second derivative $s''(t)$, also written as $\frac{d^2s}{dt^2}$, is the first derivative of $v(t)$. Hence, the second derivative of the displacement, or position, function is a measure of the rate at which the velocity is changing, i.e. it represents the acceleration of the object, which we express as

$$a(t) = v'(t) = s''(t) \quad \text{or} \quad a(t) = \frac{dv}{dt} = \frac{d^2s}{dt^2}.$$

Example 18

An object moves along a straight line so that after t seconds its displacement from the origin is s metres. Given that $s(t) = -2t^3 + 6t^2$, answer the following:

- Find expressions for the (i) velocity and (ii) acceleration at time t seconds.
- Find the (i) initial velocity and (ii) initial acceleration of the object (i.e. at time when $t = 0$).
- Find the (i) maximum displacement and (ii) maximum velocity for the interval $0 \leq t \leq 3$.

Solution

$$\text{a) (i) } v(t) = \frac{ds}{dt} = \frac{d}{dt}(-2t^3 + 6t^2) = -6t^2 + 12t$$

$$\text{(ii) } a(t) = \frac{d^2s}{dt^2} = \frac{dv}{dt} = \frac{d}{dt}(-6t^2 + 12t) = -12t + 12$$

$$\text{b) (i) } v(0) = -6(0)^2 + 12(0) = 0 \quad \Rightarrow \quad \text{The object's initial velocity is } 0 \text{ m s}^{-1}.$$

$$\text{(ii) } a(0) = -12(0) + 12 = 12 \quad \Rightarrow \quad \text{The object's initial acceleration is } 12 \text{ m s}^{-2}.$$

It would be incorrect to graph a function and its first and/or second derivative on the same axes. For example, the position $s(t)$, velocity $v(t)$ and acceleration $a(t)$ functions graphed on separate axes in Figure 13.20 will have different units on each vertical axis: metres for $s(t)$, metres per second for $v(t)$ and metres per second per second for $a(t)$.

Displacement can be negative, positive or zero. **Distance** is the absolute value of displacement. **Velocity** can be negative, positive or zero. **Speed** is the absolute value of velocity.

- c) (i) To find the maximum displacement, we can apply the first derivative test to $s(t)$. Since the first derivative of displacement, $s(t)$, is velocity, $v(t)$, then the critical points of $s(t)$ are where the velocity is zero (stationary points) and domain endpoints.

$$\begin{aligned} s'(t) = v(t) = -6t^2 + 12t = 0 &\Rightarrow 6t(-t + 2) = 0 \\ &\Rightarrow v(t) = 0 \text{ when } t = 0 \text{ or } t = 2 \end{aligned}$$

For the interval $0 \leq t \leq 3$, the critical points to be tested for finding the maximum displacement are at $t = 0$, $t = 2$ and $t = 3$. Check whether the velocity is increasing or decreasing on either side of the stationary point at $t = 2$ by finding the sign of $v(t)$ for $t = 1$ and $t = 2.5$.

$$v(1) = -6(1)^2 + 12(1) = 6 \text{ and } v(2.5) = -6(2.5)^2 + 12(2.5) = -7.5$$

Hence, the displacement s is increasing for $0 < t < 2$ and decreasing for $2 < t < 3$. This indicates that the stationary point at $t = 2$ must be an absolute maximum for s in the interval $0 \leq t \leq 3$.

$$s(2) = -2(2)^3 + 6(2)^2 = 8$$

Therefore, the object has a maximum displacement of 8 metres at $t = 2$ seconds.

- (ii) To find the maximum velocity, we can apply the first derivative test to $v(t)$. The first derivative of $v(t)$ is acceleration $a(t)$, which is the *second* derivative of $s(t)$. Hence, where $s''(t) = 0$ (acceleration is zero) indicates critical points for $v(t)$, i.e. where velocity may change from increasing to decreasing, or vice versa.

$$\begin{aligned} s''(t) = a(t) = \frac{d}{dt}(-6t^2 + 12t) &= -12t + 12 \\ \Rightarrow 12(-t + 1) = 0 &\Rightarrow a(t) = 0 \text{ when } t = 1 \end{aligned}$$

For the interval $0 \leq t \leq 3$, the critical points to be tested for finding the maximum velocity are at $t = 0$, $t = 1$ and $t = 3$. Check whether the velocity is increasing or decreasing on either side of $t = 1$ by finding the sign of $a(t)$ for $t = 0.5$ and $t = 2$.

$$a(0.5) = -12(0.5) + 12 = 6 \text{ and } a(2) = -12(2) + 12 = -12$$

Hence, the velocity v is increasing for $0 < t < 1$ and decreasing for $1 < t < 3$. This indicates that the point at $t = 1$ must be an absolute maximum for v in the interval $0 \leq t \leq 3$.

$$v(1) = -6(1)^2 + 12(1) = 6$$

Therefore, the object has a maximum velocity of 6 metres per second at $t = 1$ second.

The second derivative of a function tells us how the first derivative of the function changes. From this we can use the second derivative, as we did the first derivative, to reveal information about the shape of the graph of a function. Note in Example 18 that the object's velocity changed from increasing to decreasing when the object's acceleration was zero at $t = 1$.

Let's examine graphically the significance of the point where acceleration is zero (i.e. velocity changing from increasing to decreasing) in connection to the displacement graph for Example 18. In other words, what can the second derivative of a function tell us about the shape of the function's graph?

Figure 13.21 shows the graphs of the displacement, velocity and acceleration functions for the motion of the object in Example 18. A dashed vertical line highlights the nature of the three graphs where $t = 1$. At this point, velocity has a maximum value and acceleration is zero. It is also where velocity changes from increasing to decreasing, which has a corresponding effect on the shape of the displacement function $s(t)$.

At the point where $t = 1$, the graph of $s(t)$ changes from curving 'upwards' (*concave up*) to curving 'downwards' (*concave down*) because its slope (corresponding to velocity) changes from increasing to decreasing. This can only occur when velocity (first derivative) has a maximum and hence where acceleration (second derivative) is zero. We can see from this illustration that for a general function $f(x)$, finding intervals where the first derivative $f'(x)$ is increasing (positive acceleration) or decreasing (negative acceleration) can be used to determine where the graph of $f(x)$ is curving upward or curving downward. A point at which a function's curvature (concavity) changes – as at $t = 1$ for the graph of $s(t)$ left – is called a **point of inflexion**.

Concavity and the second derivative

The graph of $f(x)$ is **concave up** where $f'(x)$ is increasing and **concave down** where $f'(x)$ is decreasing. It follows that:

- (i) if $f''(x) > 0$ for all x in some interval of the domain of f , the graph of f is concave up in the interval

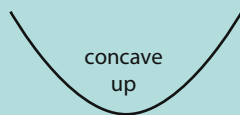

- (ii) if $f''(x) < 0$ for all x in some interval of the domain of f , the graph of f is concave down in the interval.

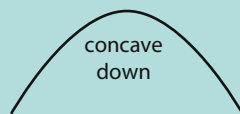

If $f(x)$ is a continuous function, its graph can only change concavity (up to down, or down to up) where $f''(x) = 0$. Hence, for a continuous function, an **inflexion point** may only occur where $f''(x) = 0$.

Note: Concavity is not defined for a line – it is neither concave up nor concave down.

Figure 13.21

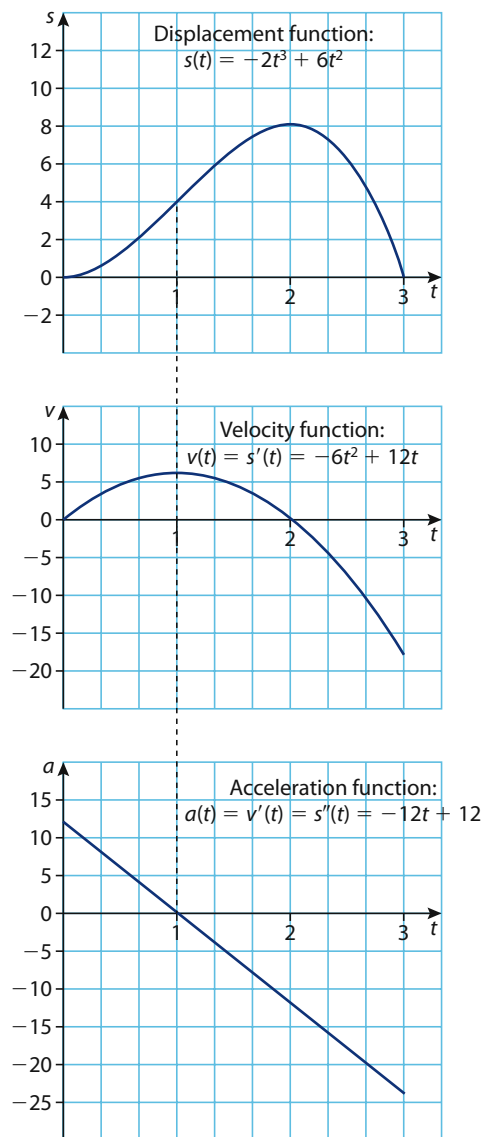

Example 19

Determine the intervals on which the graph of $y = x^4 - 4x^3$ is concave up or concave down and identify any inflexion points.

Solution

We first note that the function is continuous for its domain of all real numbers. To locate points of inflexion, we then find for what value(s) the second derivative is zero.

$$\begin{aligned}\frac{dy}{dx} &= \frac{d}{dx}(x^4 - 4x^3) = 4x^3 - 12x^2 \\ \Rightarrow \frac{d^2y}{dx^2} &= \frac{d}{dx}(4x^3 - 12x^2) = 12x^2 - 24x = 12x(x - 2)\end{aligned}$$

Setting $\frac{d^2y}{dx^2} = 0$, it follows that inflexion points may occur at $t = 0$ and $t = 2$. These two values divide the domain of the function into three intervals that we need to test. Let's choose $t = -1$, $t = 1$ and $t = 3$ as our test values. At $t = -1$, $\frac{d^2y}{dx^2} = 36 > 0$; at $t = 1$, $\frac{d^2y}{dx^2} = -12 < 0$; and at $t = 3$, $\frac{d^2y}{dx^2} = 36 > 0$. These results can be organized in a sign chart, illustrating that the graph of $y = x^4 - 4x^3$ is concave up for the open intervals $(-\infty, 0)$ and $(2, \infty)$, and concave down on the open interval $(0, 2)$.

At $t = 0$, $y = 0$ and at $t = 2$, $y = 2^4 - 4(2)^3 = -16$. Therefore, $(0, 0)$ and $(2, -16)$ are inflexion points because it is at these points the concavity of the graph changes.

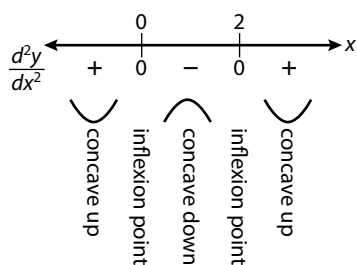
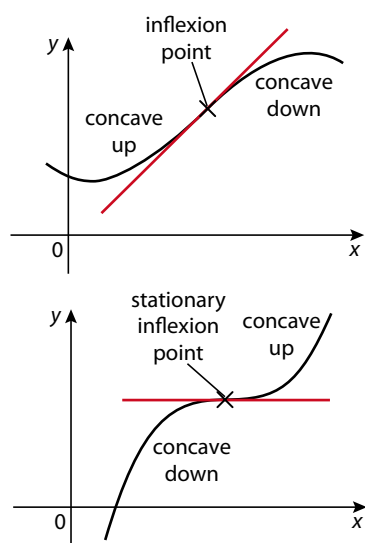
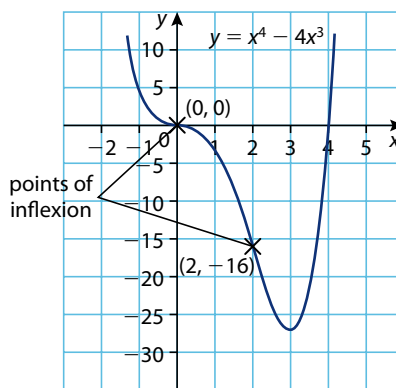
**Figure 13.22** Inflexion points.**Figure 13.23** The concavity of a graph changes at a point of inflexion.

The graph of the function (Figure 13.22) from Example 19 reveals two different types of inflexion points. The slope of the curve at $(0, 0)$ is zero – i.e. it is a stationary point. The slope of the curve at the other inflexion point, $(2, -16)$, is negative.

For either type of inflexion point, the graph crosses its tangent line at the point of inflexion, as shown in Figure 13.23.

The fact that the second derivative of a function is zero at a certain point does not guarantee that an inflexion point exists at the point.

The functions $y = x^3$ and $y = x^4$ will serve to illustrate that $\frac{d^2y}{dx^2} = 0$ is a necessary but not sufficient condition for the existence of an inflexion point.

- For $y = x^3$: $\frac{dy}{dx} = \frac{d}{dx}(x^3) = 3x^2 \Rightarrow \frac{d^2y}{dx^2} = \frac{d}{dx}(3x^2) = 6x \Rightarrow \frac{d^2y}{dx^2} = 0$ at $x = 0$. We can conclude from this that there may be an inflexion point at $x = 0$. We need to investigate further by checking to see if $\frac{d^2y}{dx^2}$ changes sign at $x = 0$. At $x = -1$, $\frac{d^2y}{dx^2} = -6$ and at $x = 1$, $\frac{d^2y}{dx^2} = 6$.

Thus, there is an inflexion point at $x = 0$ (confirmed by graph) because the second derivative changes sign at $x = 0$.

- For $y = x^4$: $\frac{dy}{dx} = \frac{d}{dx}(x^4) = 4x^3 \Rightarrow \frac{d^2y}{dx^2} = \frac{d}{dx}(4x^3) = 12x^2 \Rightarrow \frac{d^2y}{dx^2} = 0$ at $x = 0$. Again, we need to see if $\frac{d^2y}{dx^2}$ changes sign at $x = 0$.

At $x = -1$, $\frac{d^2y}{dx^2} = 12$ and at $x = 1$, $\frac{d^2y}{dx^2} = 12$. Thus, there is *no* inflexion point at $x = 0$ (confirmed by graph) because the second derivative does *not* change sign at $x = 0$.

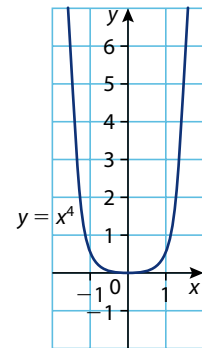
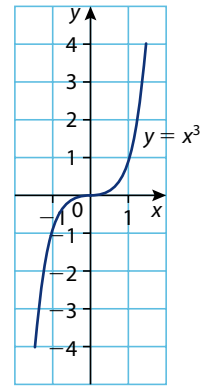

The second derivative test

Earlier in this section, we developed the first derivative test for locating maxima and minima of a function. Instead of using the first derivative to check whether a function changes from increasing to decreasing (maximum) or decreasing to increasing (minimum) at a stationary point, we can simply evaluate the second derivative at the stationary point. If the graph is concave up at the stationary point then it will be a minimum, and if it is concave down then it will be a maximum. If the second derivative is zero at a stationary point (as for $y = x^3$ and $y = x^4$), no conclusion can be made and we need to go back to the first derivative test. Using the second derivative in this way is a very efficient method for telling us whether a stationary point is a relative maximum or minimum.

The second derivative test

1. If $f'(c) = 0$ and $f''(c) < 0$, then f has a relative maximum at $x = c$.

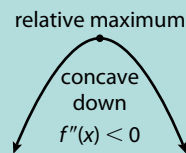

2. If $f'(c) = 0$ and $f''(c) > 0$, then f has a relative minimum at $x = c$.

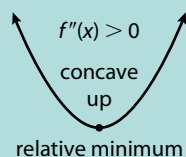

If $f''(c) = 0$, the test fails and the first derivative test should be applied.

Example 20

Find any relative extrema for $f(x) = 3x^5 - 25x^3 + 60x + 20$.

Solution

The implied domain of f is all real numbers. Solve $f'(x) = 0$ to obtain possible extrema.

$$\begin{aligned} f'(x) &= 15x^4 - 75x^2 + 60 = 0 \\ 15(x^4 - 5x^2 + 4) &= 0 \\ 15(x^2 - 4)(x^2 - 1) &= 0 \\ 15(x + 2)(x - 2)(x + 1)(x - 1) &= 0 \end{aligned}$$

Therefore, f has four stationary points: $x = -2$, $x = -1$, $x = 1$ and $x = 2$.

Applying the second derivative test:

$$\begin{aligned} f''(x) &= 60x^3 - 150x = 30x(2x^2 - 5) \\ f''(-2) &= -180 < 0 \Rightarrow f \text{ has a relative maximum at } x = -2 \\ f''(-1) &= 90 > 0 \Rightarrow f \text{ has a relative minimum at } x = -1 \\ f''(1) &= -90 < 0 \Rightarrow f \text{ has a relative maximum at } x = 1 \\ f''(2) &= 180 > 0 \Rightarrow f \text{ has a relative minimum at } x = 2 \end{aligned}$$

Exercise 13.3

In questions 1–3, find the vertex of the parabola using differentiation.

$$\mathbf{1} \ y = x^2 - 2x - 6 \qquad \mathbf{2} \ y = 4x^2 + 12x + 17 \qquad \mathbf{3} \ y = -x^2 + 6x - 7$$

For questions 4–7, a) find the derivative, $f'(x)$, b) indicate the interval(s) for which $f(x)$ is increasing, and c) the interval(s) for which $f(x)$ is decreasing.

$$\begin{aligned} \mathbf{4} \ y &= x^2 - 5x + 6 & \mathbf{5} \ y &= 7 - 4x - 3x^2 \\ \mathbf{6} \ y &= \frac{1}{3}x^3 - x & \mathbf{7} \ y &= x^4 - 4x^3 \end{aligned}$$

For questions 8–13:

- find the coordinates of any stationary points for the graph of the equation
- state, with reasoning, whether each stationary point is a minimum, maximum or neither
- sketch a graph of the equation and indicate the coordinates of each stationary point on the graph.

$$\begin{aligned} \mathbf{8} \ y &= 2x^3 + 3x^2 - 72x + 5 & \mathbf{9} \ y &= \frac{1}{6}x^3 - 5 \\ \mathbf{10} \ y &= x(x - 3)^2 & \mathbf{11} \ y &= x^4 - 2x^3 - 5x^2 + 6 \\ \mathbf{12} \ y &= x^3 - 2x^2 - 7x + 10 & \mathbf{13} \ y &= x - \sqrt{x} \end{aligned}$$

- An object moves along a line such that its displacement, s metres, from the origin O is given by $s(t) = t^3 - 4t^2 + t$.
 - Find expressions for the object's velocity and acceleration in terms of t .
 - For the interval $-1 \leq t \leq 3$, sketch the displacement-time, velocity-time, and acceleration-time graphs on separate sets of axes, vertically aligned as in Figure 13.21.
 - For the interval $-1 \leq t \leq 3$, find the time at which the displacement is a maximum and find its value.
 - For the interval $-1 \leq t \leq 3$, find the time at which the velocity is a minimum and find its value.
 - In words, accurately describe the motion of the object during the interval $-1 \leq t \leq 3$.

For each function $f(x)$ in questions 15–20, find any relative extrema and points of inflexion. State the coordinates of any such points. Use your GDC to assist you in sketching the function.

15 $f(x) = x^3 - 12x$

16 $f(x) = \frac{1}{4}x^4 - 2x^2$

17 $f(x) = x + \frac{4}{x}$

18 $y = x^2 - \frac{1}{x}$

19 $f(x) = -3x^5 + 5x^3$

20 $f(x) = 3x^4 - 4x^3 - 12x^2 + 5$

21 An object moves along a line such that its displacement, s metres, from a fixed point P is given by $s(t) = t(t - 3)(8t - 9)$.

- Find the initial velocity and initial acceleration of the object.
- Find the velocity and acceleration of the object at $t = 3$ seconds.
- Find for what values of t the object changes direction. What significance do these times have in connection to the displacement of the object?
- Find for what value of t the object's velocity is a minimum. What significance does this time have in connection to the acceleration of the object?

22 The delivery cost per tonne of bananas, D (in thousands of dollars), when x tonnes of bananas are shipped is given by $D = 3x + \frac{100}{x}$, $x > 0$. Find the value of x for which the delivery cost per tonne of bananas is a minimum, and find the value of the minimum delivery cost. Explain why this cost is a minimum rather than a maximum.

23 The curve $y = x^4 + ax^2 + bx + c$ passes through the point $(-1, -8)$ and at that point $\frac{d^2y}{dx^2} = \frac{dy}{dx} = 6$. Find the values of a , b and c and sketch the curve.

24 Find any maxima, minima or stationary points of inflexion of the function

$$f(x) = \frac{x^3 + 3x - 1}{x^2},$$

stating, with explanation, the nature of each point. Sketch the curve, indicating clearly what happens as $x \rightarrow \pm\infty$.

25 For each of the five functions graphed below sketch its derivative on a separate pair of axes. Do not use your GDC. It is helpful to use the result from question 25 in Exercise 13.2 – that the derivative of an even function is odd and the derivative of an odd function is even.

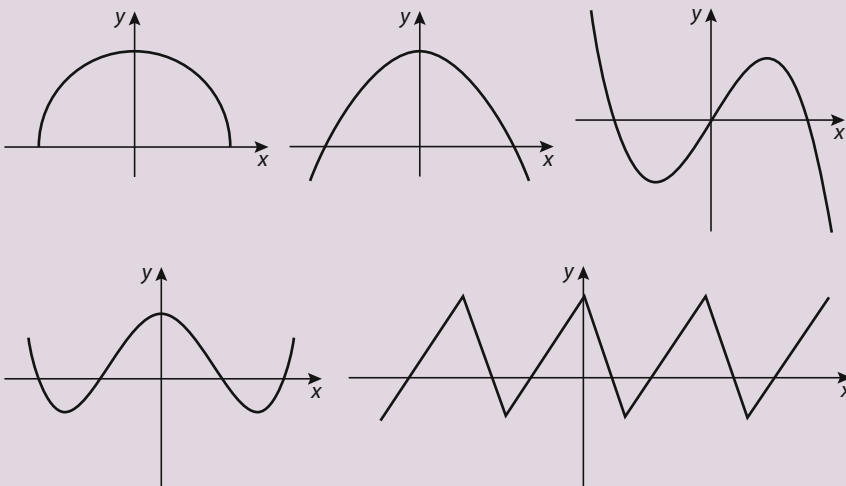

In questions 26 and 27, the graph of the **derivative** of a function f is shown.

- On what intervals is f increasing or decreasing?
- At what value(s) of x does f have a local maximum or minimum?

26

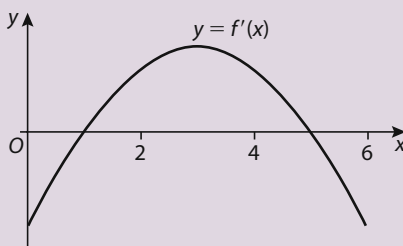

27

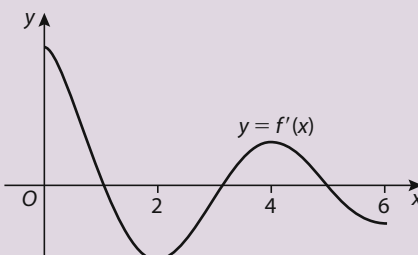

- 28** The graph of the **second derivative** f'' of a function f is shown. Approximate the x -coordinates of the inflexion points of f . Give reasons for your answers.

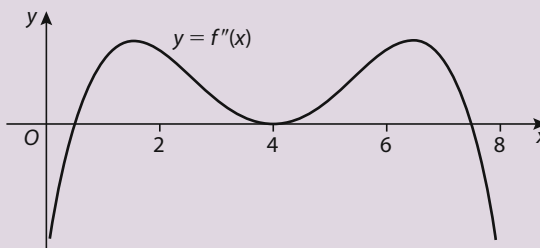

- 29** Sketch a continuous curve $y = f(x)$ with the following properties. Label coordinates where possible.

$$f(-2) = 8 \quad f(0) = 4 \quad f(2) = 0 \quad f'(2) = f'(-2) = 0$$

$$f'(x) > 0 \text{ for } |x| > 2 \quad f'(x) < 0 \text{ for } |x| < 2 \quad f''(x) < 0 \text{ for } x < 0 \quad f''(x) > 0 \text{ for } x > 0$$

- 30** An object moves along a horizontal line such that its displacement, s metres, from its starting position at any time $t \geq 0$ is given by the function $s(t) = -2t^3 + 15t^2 - 24t$. The positive direction is to the right.
- Find the intervals of time when the object is moving to the right, and the intervals when it is moving to the left.
 - Find the (i) initial velocity, and (ii) initial acceleration of the object.
 - Find the (i) maximum displacement, and (ii) maximum velocity for the interval $0 \leq t \leq 5$.
 - When is the object's acceleration equal to zero? Describe the motion of the object at this time.
- 31**
- Use your GDC to approximate to three significant figures the maximum and minimum values of the function $f(x) = x - \sqrt{2} \sin x$ in the interval $0 \leq x \leq 2\pi$.
 - Find $f'(x)$ and find the exact minimum and maximum values for $f(x)$ in the interval $0 \leq x \leq 2\pi$.

13.4 Tangents and normals

In many areas of mathematics and physics, it is useful to have an accurate description of a line that is tangent or normal (perpendicular) to a curve. The most complete mathematical description we can obtain is to find the algebraic equation of such lines. In this chapter, much of our work has been in connection to the slopes of tangent lines, so this will be our starting point.

Finding equations of tangents

We now make use of the basic differentiation rules that we established earlier to determine the equation of lines that are tangent to a curve at a point. The first example shows how we can approximate the square root of a number quite accurately without a calculator by making use of a tangent line.

Example 21

- Find the equation of the line tangent to $y = \sqrt{x}$ at $x = 9$.
- Use this tangent line to approximate $\sqrt{10}$.

Solution

- We can find the equation of any line if we know its slope and a point it passes through. Since $y = 3$ when $x = 9$, the point of tangency is $(9, 3)$. We differentiate to find the slope of the curve at $x = 9$, thus giving us the slope of the tangent line.

$$\frac{dy}{dx} = \frac{d}{dx}(\sqrt{x}) = \frac{d}{dx}(x^{\frac{1}{2}}) = \frac{1}{2}x^{-\frac{1}{2}} = \frac{1}{2\sqrt{x}}$$

$$\text{At } x = 9: \frac{dy}{dx} = \frac{1}{2\sqrt{9}} = \frac{1}{6} \Rightarrow \text{The slope of the curve and tangent line at } x = 9 \text{ is } \frac{1}{6}.$$

Now that we have a point and a slope for the line we can substitute in the point-slope form for the equation of a line.

$$y - 3 = \frac{1}{6}(x - 9) \Rightarrow y = \frac{1}{6}x + \frac{3}{2}$$

The equation of the line tangent to $y = \sqrt{x}$ at $x = 9$ is $y = \frac{x}{6} + \frac{3}{2}$.

- For values of x near 9, $y = \sqrt{x} \approx \frac{x}{6} + \frac{3}{2}$.

$$\sqrt{10} \approx \frac{10}{6} + \frac{3}{2} = \frac{19}{6} \quad \begin{array}{r} 3.\overline{16} \\ 6 \overline{)19.00} \end{array}$$

The actual value of $\sqrt{10}$ to 4 significant figures is 3.162. Our approximation expressed to 3 significant figures is 3.167. The percentage error is less than 0.2%.

Figure 13.24

Finding the tangent to a curve was a challenge that motivated many of the initial developments of calculus in the 17th century. In one of his books on mathematics, Descartes wrote the following about the problem of how to find a tangent to a curve:

And I dare say that this is not only the most useful and most general problem in geometry that I know, but even that I have ever desired to know.

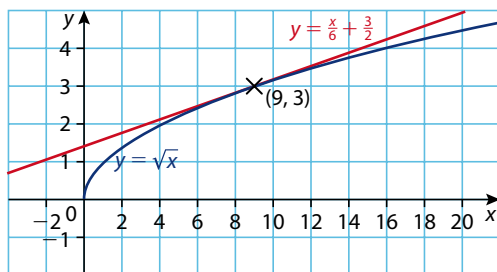

The graphs of $y = \sqrt{x}$ and its tangent at $x = 9$, $y = \frac{x}{6} + \frac{3}{2}$, in Figure 13.24 illustrate that the tangent is a very good approximation to the curve in the interval $5 < x < 13$ centred on the point of tangency $(9, 3)$.

Example 22

Find the equation of the tangent to $f(x) = x + \frac{1}{x}$ at the point $(\frac{1}{2}, \frac{5}{2})$.

Solution

$$f(x) = x + \frac{1}{x} = x + x^{-1}$$

$$f'(x) = 1 - x^{-2} = 1 - \frac{1}{x^2}$$

When $x = \frac{1}{2}$, $f'(\frac{1}{2}) = 1 - \frac{1}{(\frac{1}{2})^2} = -3$. Hence, the slope of the tangent is -3 .

$$y - \frac{5}{2} = -3\left(x - \frac{1}{2}\right) \Rightarrow y = -3x + \frac{3}{2} + \frac{5}{2} \Rightarrow y = -3x + 4$$

The equation of the line tangent to $f(x) = x + \frac{1}{x}$ at $x = \frac{1}{2}$ is $y = -3x + 4$.

Example 23

Consider the function $g(x) = x^2(x - 1)$.

- Find the two points on the graph of g at which the slope of the curve is 8.
- Find the equations of the tangents at both of these points.

Solution

- In order to differentiate by applying the power rule term-by-term, we first need to write the equation for g in expanded form:

$$g(x) = x^2(x - 1) = x^3 - x^2$$

$$g'(x) = \frac{d}{dx}(x^3 - x^2) = 3x^2 - 2x$$

$$g'(x) = 3x^2 - 2x = 8 \Rightarrow 3x^2 - 2x - 8 = 0$$

$$(3x + 4)(x - 2) = 0 \Rightarrow x = -\frac{4}{3} \text{ or } x = 2$$

$$g\left(-\frac{4}{3}\right) = \left(-\frac{4}{3}\right)^3 - \left(-\frac{4}{3}\right)^2 = -\frac{112}{27} \text{ and } g(2) = 2^3 - 2^2 = 4$$

Thus, the slope of the curve is equal to 8 at the points $\left(-\frac{4}{3}, -\frac{112}{27}\right)$ and $(2, 4)$.

b) Tangent at $(-\frac{4}{3}, -\frac{112}{27})$:

$$y - \left(-\frac{112}{27}\right) = 8 \left[x - \left(-\frac{4}{3}\right)\right] \Rightarrow y = 8x + \frac{32}{3} - \frac{112}{27}$$

$$\Rightarrow y = 8x + \frac{176}{27}$$

Therefore, the equation of the tangent at $(-\frac{4}{3}, -\frac{112}{27})$ is $y = 8x + \frac{176}{27}$.

Tangent at $(2, 4)$:

$$y - 4 = 8(x - 2) \Rightarrow y = 8x - 16 + 4 \Rightarrow y = 8x - 12$$

Therefore, the equation of the tangent at $(2, 4)$ is $y = 8x - 12$.

Figure 13.25 shows the results for Example 23 – the graph of the function g and the two tangent lines to the graph of the function that have a slope of 8. Note that the scales on the x - and y -axes are not equal which causes the slope of the tangent lines to appear less than 8 for this particular graph.

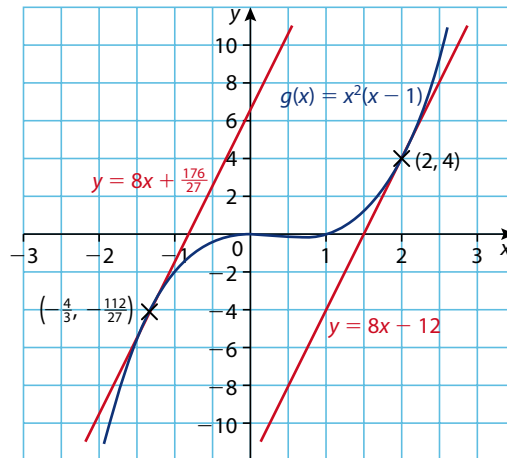
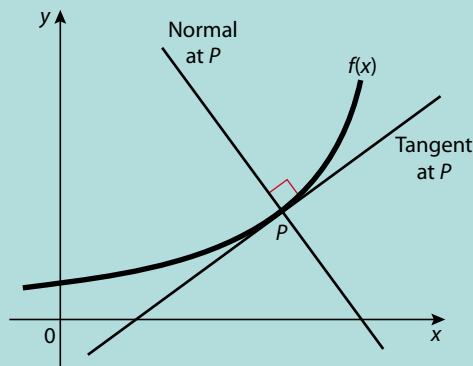

Figure 13.25

The normal to a curve at a point

Another line we often need to find is the line that is ‘perpendicular’ to a curve at a certain point, which we define to be the line that is perpendicular to the tangent at that point. In this particular context, we apply the adjective ‘normal’ rather than ‘perpendicular’ to denote that two lines are at right angles to one another.

A **normal** to a graph of a function at a point is the line through the point that is at a right angle to the tangent at the point. In other words, the tangent and normal to a curve at a certain point are perpendicular.



Recall that two perpendicular lines have slopes that are opposite reciprocals. If the slopes of two perpendicular lines are m_1 and m_2 , then

$$m_1 = -\frac{1}{m_2} \text{ or } m_1 m_2 = -1.$$

The exception is if one of the lines is horizontal (slope is zero) and the other is vertical (slope is undefined).

Example 24

Find the equation of the normal to the graph of $y = 2x^2 - 6x + 3$ at the point $(1, -1)$.

Solution

$$\frac{dy}{dx} = \frac{d}{dx}(2x^2 - 6x + 3) = 4x - 6$$

Slope of tangent at $(1, -1)$ is $4(1) - 6 = -2$. Hence, slope of normal is $+\frac{1}{2}$.

$$\text{Equation of normal: } y - (-1) = \frac{1}{2}(x - 1) \Rightarrow y = \frac{1}{2}x - \frac{3}{2}$$

Figure 13.26 shows the results for Example 24 with the curve at both its tangent and normal at the point $(1, -1)$. Please be aware that if you graph a function with its tangent and normal at a certain point, the normal will only appear perpendicular if the scales on both the x - and y -axes are equal. Regardless of whether the scales are equal or not, the tangent will always appear tangent to the curve.

Figure 13.26

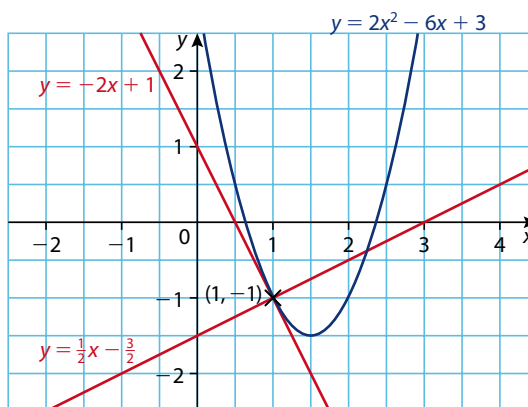
**Example 25**

Consider the parabola with equation $y = \frac{1}{4}x^2$.

- Find the equation of the normals at the points $(-2, 1)$ and $(-4, 4)$.
- Show that the point of intersection of these two normals lies on the parabola.

Solution

$$\text{a) } \frac{dy}{dx} = \frac{1}{2}x$$

Slope of tangent at $(-2, 1)$ is $\frac{1}{2}(-2) = -1$, so the slope of the normal at that point is $+1$.

Then equation of normal at $(-2, 1)$ is: $y - 1 = x - (-2) \Rightarrow y = x + 3$

Slope of tangent at $(-4, 4)$ is $\frac{1}{2}(-4) = -2$, so the slope of the normal at that point is $\frac{1}{2}$.

$$\begin{aligned} \text{Then equation of normal at } (-4, 4) \text{ is: } y - 4 &= \frac{1}{2}[x - (-4)] \\ &\Rightarrow y = \frac{1}{2}x + 6 \end{aligned}$$

- b) Set the equations of the two normals equal to each other to find their intersection.

$$\begin{aligned}x + 3 &= \frac{1}{2}x + 6 \Rightarrow \frac{1}{2}x = 3 \Rightarrow x = 6 \text{ then } y = 9 \\ &\Rightarrow \text{intersection point is } (6, 9)\end{aligned}$$

Substitute the coordinates of the points into the equation for the parabola.

$$y = \frac{1}{4}x^2 \Rightarrow 9 = \frac{1}{4}(6)^2 \Rightarrow 9 = \frac{1}{4} \cdot 36 \Rightarrow 9 = 9$$

This confirms that the intersection point, (6, 9), of the normals is also a point on the parabola.

Exercise 13.4

- Find an equation of the tangent line to the graph of the equation at the indicated value of x .
 - $y = x^2 + 2x + 1$ $x = -3$
 - $y = x^3 + x^2$ $x = -\frac{2}{3}$
 - $y = 3x^2 - x + 1$ $x = 0$
 - $y = 2x + \frac{1}{x}$ $x = \frac{1}{2}$
- Find the equations of the normal to the functions in question 1 at the indicated value of x .
- Find the equations of the lines tangent to the curve $y = x^3 - 3x^2 + 2x$ at any point where the curve intersects the x -axis.
- Find the equation of the tangent to the curve $y = x^2 - 2x$ that is perpendicular to the line $x - 2y = 1$.
- Using your GDC for assistance, make accurate sketches of the curves $y = x^2 - 6x + 20$ and $y = x^3 - 3x^2 - x$ on the same set of axes. The two curves have the same slope at an integer value for x somewhere in the interval $0 \leq x \leq \frac{3}{2}$.
 - Find this value of x .
 - Find the equation for the line tangent to each curve at this value of x .
- Find the equation of the normal to the curve $y = x^2 + 4x - 2$ at the point where $x = -3$. Find the coordinates of the other point where this normal intersects the curve again.
- Consider the function $g(x) = \frac{1 - x^3}{x^4}$. Find the equation of both the tangent and the normal to the graph of g at the point (1, 0).
- The normal to the curve $y = ax^{\frac{1}{2}} + bx$ at the point where $x = 1$ has a slope of 1 and intersects the y -axis at (0, -4). Find the value of a and the value of b .
- Find the equation of the tangent to the function $f(x) = x^3 + \frac{1}{2}x^2 + 1$ at the point $(-1, \frac{1}{2})$.
 - Find the coordinates of another point on the graph of f where the tangent is parallel to the tangent found in a).
- Find the equation of both the tangent and the normal to the curve $y = \sqrt{x}(1 - \sqrt{x})$ at the point where $x = 4$.

- 11** Consider the function $f(x) = (1 + x)^2(5 - x)$.
- Show that the line tangent to the graph of f where $x = 1$ does not intersect the graph of the function again.
 - Also show that the tangent line at $(0, 5)$ intersects the graph of f at a turning point.
 - Sketch the graph of f and the two tangents from a) and b).
- 12** Find equations of both lines through the point $(2, -3)$ that are tangent to the parabola $y = x^2 + x$.
- 13** Find all tangent lines through the origin to the graph of $y = 1 + (x - 1)^2$.
- 14** a) Find the equation of the tangent line to $y = \sqrt[3]{x}$ at $x = 8$.
 b) Use the equation of this tangent line to approximate $\sqrt[3]{9}$ to three significant figures.
- 15** Find the equation of the tangent line for $f(x) = \frac{1}{\sqrt{x}}$ at $x = a$.
- 16** The tangent to the graph of $y = x^3$ at a point P intersects the curve again at another point Q .
 Find the coordinates of Q in terms of the coordinates of P .
- 17** Two circles of radius r are tangent to each other. Two lines pass through the centre of one circle and are tangent to the other circle at points A and B as shown in the diagram. Find an expression for the distance between A and B .

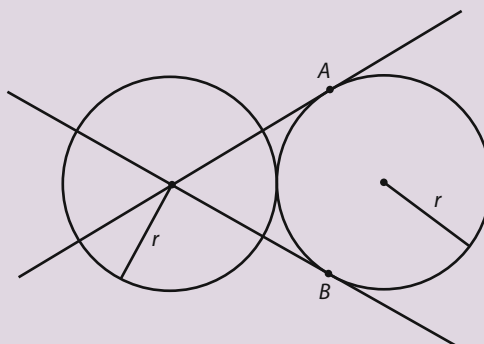

- 18** Prove that there is no line through the point $(1, 2)$ that is tangent to the curve $y = 4 - x^2$.

Practice questions

- 1** The function f is defined as $f(x) = x^2$.
- Find the gradient (slope) of f at the point P , where $x = 1.5$.
 - Find an equation for the tangent to f at the point P .
 - Draw a diagram to show clearly the graph of f and the tangent at P .
 - The tangent of part **b**) intersects the x -axis at the point Q and the y -axis at the point R . Find the coordinates of Q and R .
 - Verify that Q is the midpoint of $[PR]$.
 - Find an equation, in terms of a , for the tangent to f at the point $S(a, a^2)$, $a \neq 0$.
 - The tangent of part **f**) intersects the x -axis at the point T and the y -axis at the point U . Find the coordinates of T and U .
 - Prove that, whatever the value of a , T is the midpoint of SU .

- 2 The curve with equation $y = Ax + B + \frac{C}{x}$, $x \in \mathbb{R}$, $x \neq 0$, has a minimum at $P(1, 4)$ and a maximum at $Q(-1, 0)$. Find the value of each of the constants A , B and C .
- 3 Differentiate:
- $x^2(2 - 3x^3)$
 - $\frac{1}{x}$
- 4 Consider the function $f(x) = \frac{8}{x} + 2x$, $x > 0$.
- Solve the equation $f'(x) = 0$. Show that the graph of f has a turning point at $(2, 8)$.
 - Find the equations of the asymptotes to the graph of f , and hence sketch the graph.
- 5 Find the coordinates of the stationary point on the curve with equation $y = 4x^2 + \frac{1}{x}$.
- 6 The curve $y = ax^3 - 2x^2 - x + 7$ has a gradient (slope) of 3 at the point where $x = 2$. Determine the value of a .
- 7 If $f(2) = 3$ and $f'(2) = 5$, find an equation of **a)** the line tangent to the graph of f at $x = 2$, and **b)** the line normal to the graph of f at $x = 2$.
- 8 The function $g(x)$ is defined for $-3 \leq x \leq 3$. The behaviour of $g'(x)$ and $g''(x)$ is given in the tables below.

x	$-3 < x < -2$	-2	$-2 < x < 1$	1	$1 < x < 3$
$g'(x)$	negative	0	positive	0	negative

x	$-3 < x < -\frac{1}{2}$	$-\frac{1}{2}$	$-\frac{1}{2} < x < 3$
$g''(x)$	positive	0	negative

Use the information above to answer the following. In each case, justify your answer.

- Write down the value of x for which g has a maximum.
 - On which intervals is the value of g decreasing?
 - Write down the value of x for which the graph of g has a point of inflexion.
 - Given that $g(-3) = 0$, sketch the graph of g . On the sketch, clearly indicate the position of the maximum point, the minimum point and the point of inflexion.
- 9 Given the function $f(x) = x^2 - 3bx + (c + 2)$, determine the values of b and c such that $f(1) = 0$ and $f'(3) = 0$.
- 10 **Figure 1** shows the graphs of the functions f_1, f_2, f_3, f_4 . **Figure 2** includes the graphs of the derivatives of the functions shown in **Figure 1**.

Figure 1

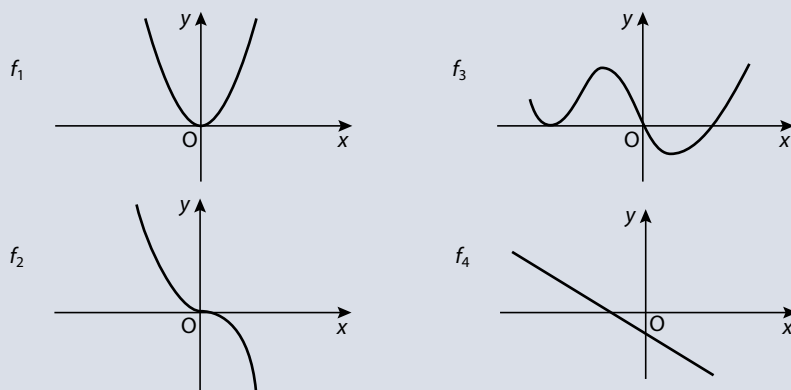
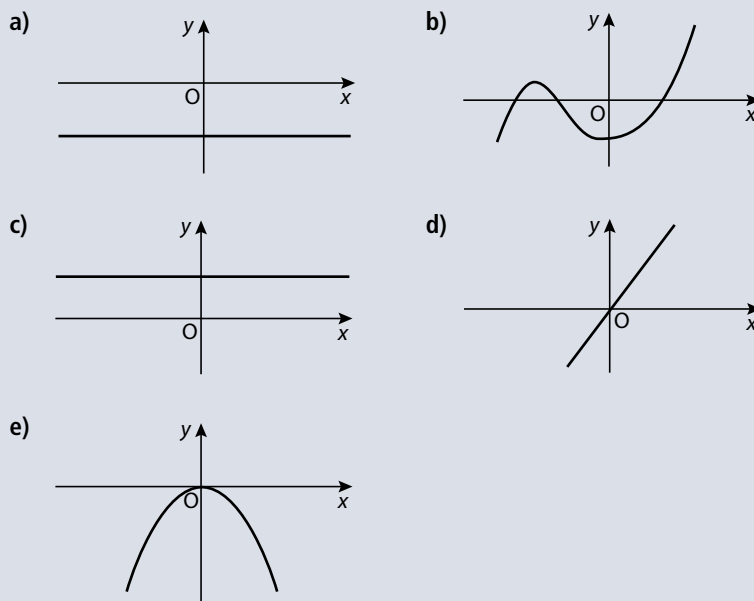

Figure 2



Complete the table below by matching each function with its derivative.

Function	Derivative diagram
f_1	
f_2	
f_3	
f_4	

11 Consider the function $f(x) = 1 + \sin x$.

- Find the average rate of change of f from $x = 0$ to $x = \frac{\pi}{2}$.
- Find the instantaneous rate of change of f at $x = \frac{\pi}{4}$.
- At what value of x in the interval $0 < x < \frac{\pi}{2}$ is the instantaneous rate of change of f equal to the average rate of change of f from $x = 0$ to $x = \frac{\pi}{2}$ (answer to part a)?)

12 Consider the function $y = \frac{3x-2}{x}$. The graph of this function has a vertical and a horizontal asymptote.

- Write down the equation of
 - the vertical asymptote
 - the horizontal asymptote.
- Find $\frac{dy}{dx}$.
- Indicate the intervals for which the curve is increasing or decreasing.
- How many stationary points does the curve have? Explain using your result to b).

- 13** Show that there are two points at which the function $h(x) = 2x^2 - x^4$ has a maximum value, and one point at which h has a minimum value. Find the coordinates of these three points, indicating whether it is a maximum or minimum.
- 14** The normal to the curve $y = x^{\frac{1}{2}} + x^{\frac{1}{3}}$ at the point $(1, 2)$ meets the axes at $(a, 0)$ and $(0, b)$.
Find a and b .
- 15** The displacement, s metres, of a car, t seconds after leaving a fixed point A , is given by $s(t) = 10t - \frac{1}{2}t^2$.
- Calculate the velocity when $t = 0$.
 - Calculate the value of t when the velocity is zero.
 - Calculate the displacement of the car from A when the velocity is zero.
- 16** A ball is thrown vertically upwards from ground level such that its height h metres at t seconds is given by $h = 14t - 4.9t^2$.
- Write expressions for the ball's velocity and acceleration.
 - Find the maximum height the ball reaches and the time it takes to reach the maximum.
 - At the moment the ball reaches its maximum height, what is the ball's velocity and acceleration?
- 17** Find the exact coordinates of the inflexion point on the curve $y = x^3 + 12x^2 - x - 12$.
- 18** Consider the function $f(x) = 2 \cos x - 3$. At the point on the curve where $x = \frac{\pi}{3}$, find:
- the equation of the line tangent to f
 - the equation of the line normal to f .
- Express both equations exactly.
- 19** A manufacturer produces closed cylindrical cans of radius r cm and height h cm. Each can has a total surface area of 54π cm².
- Solve for h in terms of r , and hence find an expression for the volume, V cm³, of each can in terms of r .
 - Find the value of r for which the cans have their maximum possible volume.
- 20** The curve $y = ax^2 + bx + c$ has a maximum point at $(2, 18)$ and passes through the point $(0, 10)$. Find a , b and c .
- 21** For the function $f(x) = \frac{1}{2}x^2 - 5x + 3$, find:
- the equation of the tangent line at $x = -2$
 - the equation of the normal line at $x = -2$.
- 22** Consider the function $f(x) = x^4 - x^3$.
- Find the coordinates of any maximum or minimum points. Identify each as relative or absolute.
 - State the domain and range of f .
 - Find the coordinates of any inflexion point(s).
 - Sketch the function clearly indicating any maximum, minimum or inflexion points.
- 23** Evaluate each limit.
- $\lim_{x \rightarrow \infty} \frac{2 - 3x + 5x^2}{8 - 3x^2}$
 - $\lim_{x \rightarrow 0} \frac{\sqrt{x+4} - 2}{x}$
 - $\lim_{x \rightarrow 1} \frac{x^3 - 1}{x - 1}$
 - $\lim_{h \rightarrow 0} \frac{\sqrt{(x+h)+2} - \sqrt{x+2}}{h}$

- 24 Find the derivative $f'(x)$ for each function.
- a) $f(x) = \frac{x^2 - 4x}{\sqrt{x}}$ b) $f(x) = x^3 - 3 \sin x$
- c) $f(x) = \frac{1}{x} + \frac{x}{2}$ d) $f(x) = \frac{7}{3x^{13}}$
- 25 A point (p, q) is on the graph of $y = x^3 + x^2 - 9x - 9$, and the line tangent to the graph at (p, q) passes through the point $(4, -1)$. Find p and q .
- 26 For what values of c , such that $c \geq 0$, is the line $y = -\frac{1}{12}x + c$ normal to the graph of $y = x^3 + \frac{1}{3}$?
- 27 Find the points on the curve $y = \frac{1}{3}x^3 - x$ where the tangent line is parallel to the line $y = 3x$.
- 28 At what point does the line that is normal to the graph of $y = x - x^2$ at the point $(1, 0)$ intersect the graph of the curve a second time?
- 29 If $f(x) = \sqrt{x+2}$, find $f'(x)$ by first principles.
- 30 An object moves along a line according to the position function $s(t) = t^3 - 9t^2 + 24t$. Find the positions of the object when
- a) its velocity is zero
- b) its acceleration is zero.
- 31 A particle moves along a straight line in the time interval $0 \leq t \leq 2\pi$ such that its displacement from the origin O is s metres given by the function $s = t + \sin t$.
- a) Find the value(s) of t in the interval $0 \leq t \leq 2\pi$ when the particle's direction changes.
- b) Show that the particle always remains on the same side of the origin O .
- c) Find the value(s) of t in the interval $0 \leq t \leq 2\pi$ when the particle's acceleration is zero.
- d) Sketch a graph of the particle's displacement from O for $0 \leq t \leq 2\pi$, and state the maximum value of s in this interval.
- 32 The curve whose equation is $y = ax^3 + bx^2 + cx + d$ has a point of inflexion at $(-1, 4)$, a turning point when $x = 2$, and it passes through the point $(3, -7)$. Find the values of a, b, c and d , and the y -coordinate of the turning point.
- 33 Find the stationary values of the function $f(x) = 1 - \frac{9}{x^2} + \frac{18}{x^4}$ and determine their nature.
- 34 a) Find the equation of the tangent to the curve $y = \frac{1}{x}$ at the point $(1, 1)$.
- b) Find the equation of the tangent to the curve $y = \cos x$ at the point $(\frac{\pi}{2}, 0)$.
- c) Deduce that $\frac{1}{x} > \cos x$ for $0 \leq x \leq \frac{\pi}{2}$.
- 35 Show that there is just one tangent to the curve $y = x^3 - x + 2$ that passes through the origin.
Find its equation and the coordinates of the point of tangency.
- 36 The displacement, s metres, of a moving body B from a fixed point O , at time t seconds, is given by $s = 50t - 10t^2 + 1000$.
- a) Find the velocity of B in m s^{-1} .
- b) Find its maximum displacement from O .

37 The diagram shows a sketch of the graph of $y = f'(x)$ for $a \leq x \leq b$.

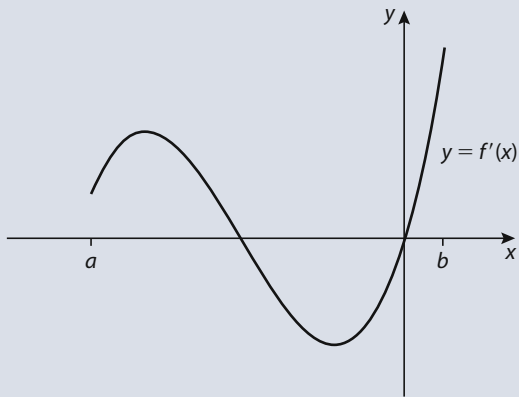

On the grid below, which has the same scale on the x -axis, draw a sketch of the graph of $y = f(x)$ for $a \leq x \leq b$, given that $f(0) = 0$ and $f(x) \geq 0$ for all x . On your graph you should clearly indicate any minimum or maximum points, or points of inflexion.

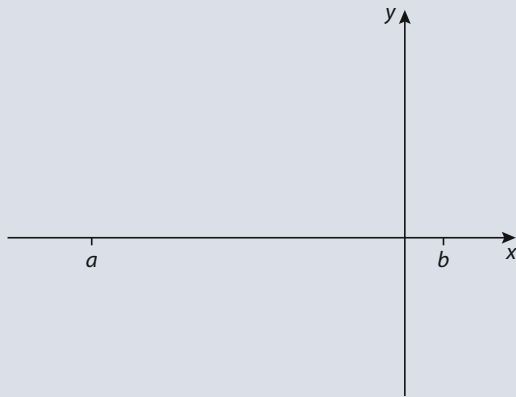

Questions 8, 10, 36 and 37 © International Baccalaureate Organization

Differential Calculus II: Further Techniques and Applications

Assessment statements

- 6.2 Derivative of x^n ($n \in \mathbb{Q}$), $\sin x$, $\cos x$, $\tan x$, e^x and $\ln x$.
Differentiation of a sum and a real multiple of a function.
The chain rule for composite functions.
Implicit differentiation.
Related rates of change.
The product and quotient rules.
Derivatives of $\sec x$, $\csc x$, $\cot x$, a^x , $\log_a x$, $\arcsin x$, $\arccos x$ and $\arctan x$.
- 6.3 Optimization problems.

Introduction

The primary purpose of the earlier chapter on calculus, Chapter 13, was to establish some fundamental concepts and techniques of differential calculus. Chapter 13 also introduced some applications involving the differentiation of functions: finding maxima and minima of a function; kinematic problems involving displacement, velocity and acceleration; and finding equations of tangents and normals. The focus of this chapter is to expand our set of differentiation rules and techniques and to deepen and extend the applications introduced in Chapter 13 – particularly using methods of finding extrema in the context of finding an ‘optimum’ solution to a problem and solving problems involving more than one rate of change. We start by investigating the derivatives of some important functions.



It is not an exaggeration to consider Isaac Newton (1642–1727) the most influential person in the development of modern science and mathematics. Newton was educated at Cambridge University and later was a professor of mathematics there. When Newton entered Cambridge in 1661, he did not know much mathematics but he learned quickly by reading works of Euclid and Descartes and attending lectures of Isaac Barrow, the first professor of mathematics at Cambridge. Cambridge was closed in 1665 and 1666 because of the Great Plague that swept through London and other parts of England. Studying and thinking on his own during these two years (and still not yet 25 years old), Newton discovered that white light can be decomposed into rays of different colours, how to represent functions using infinite series (including the binomial theorem), formulated the law of universal gravitation, and developed differential and integral calculus (several years before its independent discovery by Leibniz – see page 707). These great discoveries were all published much later because of Newton’s fear of criticism and controversy. In 1687, Newton published his *Principia Mathematica*, one of the greatest scientific works ever written, in which he presented his version of calculus and applied it to investigate and explain a wide range of physical phenomena.

Newton’s intellectual interests were not restricted to physics and mathematics. He left behind many papers dealing with theology and alchemy (attempting to change ordinary metals into gold). He was also a successful Warden of the Royal Mint (overseeing the production of official coins) and held political office, representing Cambridge University in Parliament several times.



15.1 Derivatives of composite functions, products and quotients

Derivatives of composite functions: the chain rule

We know how to differentiate functions such as $f(x) = x^3 + 2x - 3$ and $g(x) = \sqrt{x}$, but how do we differentiate the composite function $f(g(x)) = \sqrt{x^3 + 2x - 3}$? The rule for computing the derivative of the composite of two functions, i.e. the ‘function of a function’, is called the **chain rule**. Because most functions that we encounter in applications are composites of other functions, it can be argued that the chain rule is the most important, and most widely used, rule of differentiation.

Below are some examples of functions that we can differentiate with the rules that we have learned thus far in Chapter 13, and further examples of functions which are best differentiated with the chain rule.

Differentiate <i>without</i> the chain rule	Differentiate <i>with</i> the chain rule
$y = \cos x$	$y = \cos 2x$
$y = 3x^2 + 5x$	$x = \sqrt{3x^2 + 5x}$
$y = \sin x$	$y = \sin^2 x$
$y = \frac{1}{3x^2}$	$y = \frac{1}{3x^2 + x}$

The chain rule says, in a very basic sense, that given two functions, the derivative of their composite is the product of their derivatives – remembering that a derivative is a rate of change of one quantity (variable) with respect to another quantity (variable). For example, the function $y = 8x + 6 = 2(4x + 3)$ is the composite of the functions $y = 2u$ and $u = 4x + 3$. Note that the function y is in terms of u , and the function u is in terms of x . How are the derivatives of these three functions related?

Clearly, $\frac{dy}{dx} = 8$, $\frac{dy}{du} = 2$ and $\frac{du}{dx} = 4$. Since $8 = 2 \cdot 4$, the derivatives relate

such that $\frac{dy}{dx} = \frac{dy}{du} \cdot \frac{du}{dx}$. In other words, rates of change multiply.

Again, if we think of derivatives as rates of change, the relationship

$\frac{dy}{dx} = \frac{dy}{du} \cdot \frac{du}{dx}$ can be illustrated by a practical example. Consider the pair of

levers in Figure 15.1 with lever endpoints U and U' connected by a segment that can shrink and stretch but always remains horizontal. Hence, points U and U' are always the same distance u from the ground.

Figure 15.1 Two levers with horizontal connection between U' and U .

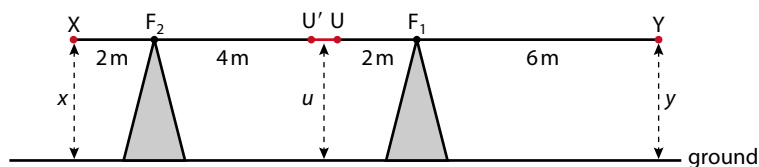

As point Y moves down, points U and U' move up, and point X moves down but at a rate different from that of Y . Let dy , du and dx represent the change in distance from the ground for the points Y , U and X , respectively. Because $YF_1 = 6$ and $UF_1 = 2$, if point Y moves such that $dy = 3$, then $du = 1$. Since $U'F_2 = 4$ and $XF_2 = 2$, if point U' moves so that $du = 2$, then $dx = 1$.

Hence, $\frac{dy}{du} = 3$ and $\frac{du}{dx} = 2$.

Figure 15.2 dx , du and dy represent the change in distance from the ground for X , U and Y .

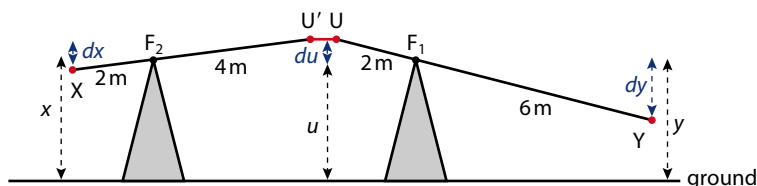

Combining these two results, we can see that for every 6 units that Y 's distance changes, X 's distance will change 1 unit. That is, $\frac{dy}{dx} = 6$.

Therefore, we can write $\frac{dy}{dx} = \frac{dy}{du} \cdot \frac{du}{dx} = 3 \cdot 2 = 6$. In other words, the rate of change of y with respect to x is the product of the rate of change of y with respect to u and the rate of change of u with respect to x .

Example 1

The polynomial function $y = 16x^4 - 8x^2 + 1 = (4x^2 - 1)^2$ is the composite of $y = u^2$ and $u = 4x^2 - 1$. Use the chain rule to find $\frac{dy}{dx}$, the derivative of y with respect to x .

Solution

$$y = u^2 \Rightarrow \frac{dy}{du} = 2u$$

$$u = 4x^2 - 1 \Rightarrow \frac{du}{dx} = 8x$$

$$\begin{aligned} \text{Applying the chain rule: } \frac{dy}{dx} &= \frac{dy}{du} \cdot \frac{du}{dx} = 2u \cdot 8x \\ &= 2(4x^2 - 1) \cdot 8x \\ &= 64x^3 - 16x \end{aligned}$$

In this particular case, we could have differentiated the function in expanded form by differentiating term-by-term rather than differentiating the factored form by the chain rule. $\frac{dy}{dx} = \frac{d}{dx}(16x^4 - 8x^2 + 1) = 64x^3 - 16x$;



confirming the result above. It is not always easier to differentiate powers of polynomials by expanding and then differentiating term-by-term.

For example, it is far better to find the derivative of $y = (3x + 5)^8$ by the chain rule.

In Section 2.2, we often wrote composite functions using nested function notation. For example, the notation $f(g(x))$ denotes a function composed of functions f and g such that g is the ‘inside’ function and f is the ‘outside’ function. For the composite function $y = (4x^2 - 1)^2$ in Example 1, the ‘inside’ function is $g(x) = 4x^2 - 1$ and the ‘outside’ function is $f(u) = u^2$. Looking again at the solution for Example 1, we see that we can choose to express and work out the chain rule in function notation rather than Leibniz notation.

For $y = f(g(x)) = (4x^2 - 1)^2$ and $y = f(u) = u^2$, $u = g(x) = 4x^2 - 1$,

Leibniz notation

$$\begin{aligned}\frac{dy}{dx} &= \frac{dy}{du} \cdot \frac{du}{dx} = 2u \cdot 8x \\ &= 2(4x^2 - 1) \cdot 8x \\ &= 64x^3 - 16x\end{aligned}$$

Function notation

$$\begin{aligned}\frac{d}{dx}[f(g(x))] &= f'(u) \cdot g'(x) = 2u \cdot 8x \\ &= f'(g(x)) \cdot g'(x) = 2(4x^2 - 1) \cdot 8x \\ &= 64x^3 - 16x\end{aligned}$$

This leads us to formally state the chain rule in two different notations.

The chain rule

If $y = f(u)$ is a function in terms of u and $u = g(x)$ is a function in terms of x , the function $y = f(g(x))$ is differentiated as follows:

$$\frac{dy}{dx} = \frac{dy}{du} \cdot \frac{du}{dx} \quad (\text{Leibniz form})$$

or, equivalently,

$$\frac{dy}{dx} = \frac{d}{dx}[f(g(x))] = f'(g(x)) \cdot g'(x) \quad (\text{function notation form})$$

Let Δu be the change in u corresponding to a change of Δx in x , that is, $\Delta u = g(x + \Delta x) - g(x)$. Then the corresponding change in y is $\Delta y = f(u + \Delta u) - f(u)$. It would be tempting to try to **prove the chain**

rule by writing $\frac{\Delta y}{\Delta x} = \frac{\Delta y}{\Delta u} \cdot \frac{\Delta u}{\Delta x}$, which is a true statement if none of the denominators are zero. Recognizing that the definition of the derivative

$f'(x) = \lim_{h \rightarrow 0} \frac{f(x+h) - f(x)}{h}$, is equivalent to $\frac{dy}{dx} = \lim_{\Delta x \rightarrow 0} \frac{\Delta y}{\Delta x}$, we could then

proceed as follows:

$$\begin{aligned}\lim_{\Delta x \rightarrow 0} \frac{\Delta y}{\Delta x} &= \lim_{\Delta x \rightarrow 0} \left(\frac{\Delta y}{\Delta u} \cdot \frac{\Delta u}{\Delta x} \right) = \lim_{\Delta x \rightarrow 0} \frac{\Delta y}{\Delta u} \cdot \lim_{\Delta x \rightarrow 0} \frac{\Delta u}{\Delta x} \\ &= \lim_{\Delta u \rightarrow 0} \frac{\Delta y}{\Delta u} \cdot \lim_{\Delta x \rightarrow 0} \frac{\Delta u}{\Delta x} \quad \text{because if } \Delta x \rightarrow 0 \text{ then } \Delta u \rightarrow 0 \\ &= \frac{dy}{du} \cdot \frac{du}{dx}\end{aligned}$$

This would work as a proof if we knew that Δu , the change in u , was non-zero – but we do not know this. It is possible that a small change in x could produce no change in u . Nonetheless, this reasoning does provide an intuitive justification relating the chain rule to the limit definition of the derivative. A properly rigorous proof can be constructed with a different approach, but we will not present it here.

The chain rule needs to be applied carefully. Consider the function

notation form for the chain rule $\frac{d}{dx}[f(g(x))] = f'(g(x)) \cdot g'(x)$. Although it is the product of two derivatives, it is important to point out that the first derivative involves the function f differentiated at $g(x)$ and the second is function g differentiated at x . The chain rule written in Leibniz form, $\frac{dy}{dx} = \frac{dy}{du} \cdot \frac{du}{dx}$, is easily remembered because it appears to be an obvious statement about fractions – but, they are *not* fractions. The expressions $\frac{dy}{dx}$, $\frac{dy}{du}$ and $\frac{du}{dx}$ are derivatives or, more precisely, limits and although du and dx essentially represent very small changes in the variables u and x , we cannot guarantee that they are non-zero.

The function notation form of the chain rule offers a very useful way of saying the rule ‘in words’, and, thus, a very useful structure for applying it.

$$\begin{array}{c} \begin{array}{cc} f \text{ is 'outside' function} & g \text{ is 'inside' function} \end{array} \\ \begin{array}{c} \swarrow \quad \searrow \\ \frac{dy}{dx} = \frac{d}{dx}[f(g(x))] = \underbrace{f'(g(x))}_{\substack{\text{derivative of 'outside' function} \\ \text{with 'inside' function unchanged}}} \cdot \underbrace{g'(x)}_{\substack{\text{derivative of 'inside' function}}} \end{array} \end{array}$$

The chain rule in words:

$$\left(\begin{array}{c} \text{derivative of} \\ \text{composite} \end{array} \right) = \left(\begin{array}{c} \text{derivative of 'outside' function} \\ \text{with 'inside' function unchanged} \end{array} \right) \times \left(\begin{array}{c} \text{derivative of} \\ \text{'inside' function} \end{array} \right)$$

Although this is taking some liberties with mathematical language, the mathematical interpretation of the phrase “with ‘inside’ function unchanged” is that the derivative of the ‘outside’ function f is evaluated at $g(x)$, the ‘inside’ function.

● **Hint:** The chain rule is our most important rule of differentiation. It is an indispensable tool in differential calculus. Forgetting to apply the chain rule when it needs to be applied, or by applying it improperly, is a common source of errors in calculus computations. It is important to understand it, practise it and master it.



The chain rule acquired its name because we use it to take derivatives of composites of functions by ‘chaining’ together their derivatives. A function could be the composite of more than two functions. If a function were the composite of three functions, we would take the product of three derivatives ‘chained’ together. For example, if $y = f(u)$, $u = g(v)$ and $v = h(x)$, the derivative of the function

$$y = f(g(h(x))) \text{ is } \frac{dy}{dx} = \frac{dy}{du} \cdot \frac{du}{dv} \cdot \frac{dv}{dx}$$

Example 2

Differentiate each function by applying the chain rule. Start by ‘decomposing’ the composite function into the ‘outside’ function and the ‘inside’ function.

a) $y = \cos 3x$

b) $y = \sqrt{3x^2 + 5x}$

c) $y = \frac{1}{3x^2 + x}$

d) $y = \sin^2 x$

e) $y = \sin x^2$

f) $y = \sqrt[3]{(7 - 5x)^2}$

Solution

a) $y = f(g(x)) = \cos 3x \Rightarrow$ ‘outside’ function is $f(u) = \cos u$
 \Rightarrow ‘inside’ function is $g(x) = 3x$

In Leibniz form: $\frac{dy}{dx} = \frac{dy}{du} \cdot \frac{du}{dx} = (-\sin u) \cdot 3 = -3 \sin(3x)$

Or, alternatively, in function notation form:

$$\frac{dy}{dx} = f'(g(x)) \cdot g'(x) = \underbrace{[-\sin(3x)]}_{\text{derivative of 'outside' function with 'inside' function unchanged}} \cdot \underbrace{3}_{\text{derivative of 'inside' function}} = -3 \sin(3x)$$

derivative of ‘outside’ function with ‘inside’ function unchanged \times derivative of ‘inside’ function

b) $y = f(g(x)) = \sqrt{3x^2 + 5x} \Rightarrow$

‘outside’ function is $f(u) = \sqrt{u} = u^{\frac{1}{2}}$

$f'(u) = \frac{1}{2}u^{-\frac{1}{2}} \Rightarrow$ ‘inside’ function is $g(x) = 3x^2 + 5x$

$$\frac{dy}{dx} = f'(g(x)) \cdot g'(x) = \frac{1}{2}(3x^2 + 5x)^{-\frac{1}{2}} \cdot (6x + 5)$$

$$\frac{dy}{dx} = \frac{6x + 5}{2(3x^2 + 5x)^{\frac{1}{2}}} \text{ or } \frac{6x + 5}{2\sqrt{3x^2 + 5x}}$$

c) $y = f(g(x)) = \frac{1}{3x^2 + x} \Rightarrow$

‘outside’ function is $f(u) = \frac{1}{u} = u^{-1}$

$f'(u) = -u^{-2} \Rightarrow$ ‘inside’ function is $g(x) = 3x^2 + x$

$$\frac{dy}{dx} = f'(g(x)) \cdot g'(x) = -(3x^2 + x)^{-2} \cdot (6x + 1)$$

$$\frac{dy}{dx} = -\frac{6x + 1}{(3x^2 + x)^2}$$

d) The expression $\sin^2 x$ is an abbreviated way of writing $(\sin x)^2$.

$$y = f(g(x)) = \sin^2 x = (\sin x)^2 \Rightarrow$$

‘outside’ function is $f(u) = u^2$

$f'(u) = 2u \Rightarrow$ ‘inside’ function is $g(x) = \sin x$

$$\frac{dy}{dx} = f'(g(x)) \cdot g'(x) = 2 \sin x \cdot \cos x$$

$$\frac{dy}{dx} = 2 \sin x \cos x$$

e) The expression $\sin x^2$ is equivalent to $\sin(x^2)$, and is **not** $(\sin x)^2$.

If $y = f(g(x)) = \sin(x^2)$, then the 'outside' function is $f(u) = \sin u$, and the 'inside' function is $g(x) = x^2$.

$$\begin{aligned} \text{By the chain rule, } \frac{dy}{dx} &= f'(g(x)) \cdot g'(x) \\ &= \cos(x^2) \cdot 2x \\ \frac{dy}{dx} &= 2x \cos(x^2) \end{aligned}$$

f) First change from radical (surd) form to rational exponent form.

$$y = \sqrt[3]{(7 - 5x)^2} = (7 - 5x)^{\frac{2}{3}}$$

$$\begin{aligned} y = f(g(x)) = (7 - 5x)^{\frac{2}{3}} &\Rightarrow \text{'outside' function } f(u) = u^{\frac{2}{3}} \\ &\Rightarrow \text{'inside' function } g(x) = 7 - 5x \end{aligned}$$

$$\begin{aligned} \text{By the chain rule, } \frac{dy}{dx} &= f'(g(x)) \cdot g'(x) \\ &= \frac{2}{3}(7 - 5x)^{-\frac{1}{3}} \cdot (-5) \\ \frac{dy}{dx} &= -\frac{10}{3(7 - 5x)^{\frac{1}{3}}} \text{ or } -\frac{10}{3(\sqrt[3]{7 - 5x})} \end{aligned}$$

• **Hint:** Aim to write a function in a way that eliminates any confusion regarding the argument of the function. For example, write $\sin(x^2)$ rather than $\sin x^2$; $1 + \ln x$ rather than $\ln x + 1$; $5 + \sqrt{x}$ rather than $\sqrt{x} + 5$; $\ln(4 - x^2)$ rather than $\ln 4 - x^2$.

Example 3

Find the derivative of the function $y = (2x + 3)^3$ by:

- expanding the binomial and differentiating term-by-term
- the chain rule.

Solution

$$\begin{aligned} \text{a) } y &= (2x + 3)^3 = (2x + 3)(2x + 3)^2 \\ &= (2x + 3)(4x^2 + 12x + 9) \\ &= 8x^3 + 24x^2 + 18x + 12x^2 + 36x + 27 \\ &= 8x^3 + 36x^2 + 54x + 27 \\ \frac{dy}{dx} &= 24x^2 + 72x + 54 \end{aligned}$$

$$\begin{aligned} \text{b) } y = f(g(x)) = (2x + 3)^3 &\Rightarrow y = f(u) = u^3; u = g(x) = 2x + 3 \\ &\Rightarrow f'(u) = 3u^2; g'(x) = 2 \end{aligned}$$

$$\begin{aligned} \frac{dy}{dx} &= \frac{dy}{du} \cdot \frac{du}{dx} = 3u^2 \cdot 2 = 6u^2 \\ &= 6(2x + 3)^2 \\ &= 6(4x^2 + 12x + 9) \\ &= 24x^2 + 72x + 54 \end{aligned}$$

The product rule

With the differentiation rules that we have learned thus far we can differentiate some functions that are products. For example, we can differentiate the function $f(x) = (x^2 + 3x)(2x - 1)$ by expanding and then differentiating the polynomial term-by-term. In doing so, we are applying the sum and difference, constant multiple and power rules from Section 13.2.

$$f(x) = (x^2 + 3x)(2x - 1) = 2x^3 + 5x^2 - 3x$$

$$f'(x) = 2 \frac{d}{dx}(x^3) + 5 \frac{d}{dx}(x^2) - 3 \frac{d}{dx}(x)$$

$$f'(x) = 6x^2 + 10x - 3$$

The sum and difference rule states that the derivative of a sum/difference of two functions is the sum/difference of their derivatives. Perhaps the derivative of the product of two functions is the product of their derivatives. Let's try this with the above example.

$$f(x) = (x^2 + 3x)(2x - 1)$$

$$f'(x) = \frac{d}{dx}(x^2 + 3x) \cdot \frac{d}{dx}(2x - 1)?$$

$$f'(x) = (2x + 3) \cdot 2?$$

$$f'(x) = 4x + 6? \quad \text{However, } 4x + 6 \neq 6x^2 + 10x - 3.$$

Thus, one important fact we have learned from this example is that the derivative of a product of two functions is *not* the product of their derivatives. However, there are many products, such as $y = (4x - 3)^3(x - 1)^4$ and $f(x) = x^2 \sin x$, for which it is either difficult or impossible to write the function as a polynomial. In order to differentiate functions like this, we need a 'product' rule.



Gottfried Wilhelm Leibniz (1646–1716)

Leibniz was a German philosopher, mathematician, scientist and professional diplomat – and, although self-taught in mathematics, was a major contributor to the development of mathematics in the 17th century. He developed the elementary concepts of calculus independent of, but slightly after, Newton. Nevertheless, the notation that Leibniz created for differential and integral calculus is still in use today. Leibniz' approach to the development of calculus was more purely mathematical, whereas Newton's was more directly connected to solving problems in physics. Leibniz created the idea of differentials (infinitely small differences in length), which he used to define the slope of a tangent, before the modern concept of limits was fully developed. Thus, Leibniz considered the derivative $\frac{dy}{dx}$ as the quotient of two differentials, dy and dx . Though it caused some confusion and consternation in his time (and to some extent still), Leibniz manipulated differentials algebraically to establish many of the important differentiation rules – including the product rule.



The product rule

If y is a function in terms of x that can be expressed as the product of two functions u and v that are also in terms of x , the product $y = uv$ can be differentiated as follows:

$$\frac{dy}{dx} = \frac{d}{dx}(uv) = u \frac{dv}{dx} + v \frac{du}{dx}$$

or, equivalently, if $y = f(x) \cdot g(x)$, then

$$\frac{dy}{dx} = \frac{d}{dx}[f(x) \cdot g(x)] = f(x) \cdot g'(x) + g(x) \cdot f'(x)$$

Proof of the product rule

Let $y = F(x) = f(x) \cdot g(x)$ where f and g are differentiable functions of x (i.e. derivative exists for all x) and their product is defined for all values of x in the domain.

We proceed by applying the limit definition of the derivative and properties of limits. Note that in the second line of the proof we have introduced the additional term, $f(x+h)g(x)$, and its opposite (thereby adding zero) in the numerator. The purpose of this is to allow us to analyze separately the changes in f and g as h goes to zero. Thus, in the fifth line we are eventually able to isolate limits that are the derivatives of f and g .

$$\begin{aligned} F'(x) &= \lim_{h \rightarrow 0} \frac{f(x+h)g(x+h) - f(x)g(x)}{h} \\ &= \lim_{h \rightarrow 0} \frac{f(x+h)g(x+h) - f(x+h)g(x) + f(x+h)g(x) - f(x)g(x)}{h} \\ &= \lim_{h \rightarrow 0} \left[f(x+h) \frac{g(x+h) - g(x)}{h} + g(x) \frac{f(x+h) - f(x)}{h} \right] \\ &= \lim_{h \rightarrow 0} \left[f(x+h) \frac{g(x+h) - g(x)}{h} \right] + \lim_{h \rightarrow 0} \left[g(x) \frac{f(x+h) - f(x)}{h} \right] \\ &= \lim_{h \rightarrow 0} f(x+h) \cdot \lim_{h \rightarrow 0} \frac{g(x+h) - g(x)}{h} + \lim_{h \rightarrow 0} g(x) \cdot \lim_{h \rightarrow 0} \frac{f(x+h) - f(x)}{h} \\ &= f(x) \cdot g'(x) + g(x) \cdot f'(x) \end{aligned}$$

A less formal but perhaps more intuitive justification can be provided by

considering the product rule written in the form

$$\frac{dy}{dx} = \frac{d}{dx}(uv) = u \frac{dv}{dx} + v \frac{du}{dx}$$

and analyzing the relationship between the functions u , v and y when there is a small change in the variable x . Recall that the definition of the

derivative (Section 13.2) is essentially the limit of $\frac{\text{change in } y}{\text{change in } x}$ as the

'change in x ' goes to zero. Let δx (read 'delta x ') and δy represent small

changes in x and y , respectively. As $\delta x \rightarrow 0$, then $\frac{\delta y}{\delta x} \rightarrow \frac{dy}{dx}$, i.e. the derivative of y with respect to x .

Any small change in x , i.e. δx , will cause small changes, δu and δv , in the values of functions u and v respectively. Since $y = uv$, these changes will also cause a small change, δy , in the value of function y .

Now consider the rectangles in Figure 15.3. The area of the first smaller rectangle is $y = uv$. The values of u and v then increase by δu and δv respectively.

The area of the larger rectangle is $y + \delta y = uv + u\delta v + v\delta u + \delta u\delta v$.

The product uv changes by the amount $\delta y = u\delta v + v\delta u + \delta u\delta v$.

Dividing through by δx : $\frac{\delta y}{\delta x} = u\frac{\delta v}{\delta x} + v\frac{\delta u}{\delta x} + \delta u\frac{\delta v}{\delta x}$.

Let $\delta x \rightarrow 0$ and $\delta u \rightarrow 0$, then:

$$\frac{\delta y}{\delta x} = u\frac{\delta v}{\delta x} + v\frac{\delta u}{\delta x} + \delta u\frac{\delta v}{\delta x} \Rightarrow \frac{dy}{dx} = u\frac{dv}{dx} + v\frac{du}{dx} + 0 \cdot \frac{dv}{dx}$$

Giving $\frac{dy}{dx} = u\frac{dv}{dx} + v\frac{du}{dx}$, the product rule.

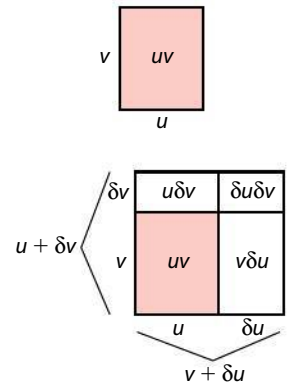

Figure 15.3

Example 4

Find the derivative of the function $y = (x^2 + 3x)(2x - 1)$ by:

- expanding the binomial and differentiating term-by-term
- the product rule.

Solution

a) Expanding gives $y = (x^2 + 3x)(2x - 1) = 2x^3 + 5x^2 - 3x$.

$$\text{Therefore, } \frac{dy}{dx} = 6x^2 + 10x - 3.$$

b) Let $u(x) = x^2 + 3x$ and $v(x) = 2x - 1$, then $y = u(x) \cdot v(x)$ or simply $y = uv$.

By the product rule (in Leibniz form),

$$\begin{aligned} \frac{dy}{dx} &= \frac{d}{dx}(uv) = u\frac{dv}{dx} + v\frac{du}{dx} = (x^2 + 3x) \cdot 2 + (2x - 1) \cdot (2x + 3) \\ &= (2x^2 + 6x) + (4x^2 + 4x - 3) \\ &= 6x^2 + 10x - 3 \end{aligned}$$

This result agrees with the derivative we obtained earlier from differentiating the expanded polynomial.

Example 5

Given $y = x^2 \sin x$, find $\frac{dy}{dx}$.

Solution

Let $y = f(x) \cdot g(x) = x^2 \sin x \Rightarrow f(x) = x^2$ and $g(x) = \sin x$.

By the product rule (function notation form),

$$\begin{aligned} \frac{dy}{dx} &= \frac{d}{dx}[f(x) \cdot g(x)] = f(x) \cdot g'(x) + g(x) \cdot f'(x) \\ &= x^2 \cdot \cos x + (\sin x) \cdot 2x \\ \frac{dy}{dx} &= x^2 \cos x + 2x \sin x \end{aligned}$$

As with the chain rule, it is very helpful to remember the structure of the product rule in words.

$$\frac{dy}{dx} = \frac{d}{dx} \underbrace{[f(x) \cdot g(x)]}_{\substack{\text{product of} \\ \text{two functions,} \\ \text{i.e. factors}}} = \underbrace{f(x)}_{\substack{\text{first} \\ \text{factor}}} \cdot \underbrace{g'(x)}_{\substack{\text{derivative} \\ \text{of second} \\ \text{factor}}} + \underbrace{g(x)}_{\substack{\text{second} \\ \text{factor}}} \cdot \underbrace{f'(x)}_{\substack{\text{derivative} \\ \text{of first} \\ \text{factor}}}$$

Example 6

Find an equation of the line tangent to the curve $y = \sin x \cos(2x)$ at the point where $x = \frac{\pi}{6}$.

Solution

To find the slope of the line tangent we need to find the derivative of $y = \sin x \cos(2x)$. To do this we will have to use more than one of the differentiation rules. Firstly, we need the product rule since the function consists of the two factors $\sin x$ and $\cos(2x)$. Secondly, the second factor is a composite of cosine and $2x$ so we need the chain rule. In essence the application of the chain rule will be ‘nested’ within the product rule.

$$\frac{dy}{dx} = \sin x \frac{d}{dx}(\cos(2x)) + \cos(2x) \frac{d}{dx} \sin x \quad \text{Product rule applied to entire function.}$$

$$\frac{dy}{dx} = \sin x(-2 \sin(2x)) + \cos(2x) \cos x \quad \text{Chain rule for } \frac{d}{dx}(\cos(2x)).$$

$$\frac{dy}{dx} = -2 \sin x \sin(2x) + \cos x \cos(2x)$$

$$\begin{aligned} \text{At } x = \frac{\pi}{6}, \frac{dy}{dx} &= -2 \sin\left(\frac{\pi}{6}\right) \sin\left(2 \cdot \frac{\pi}{6}\right) + \cos\left(\frac{\pi}{6}\right) \cos\left(2 \cdot \frac{\pi}{6}\right) \\ &= -2 \sin\left(\frac{\pi}{6}\right) \sin\left(\frac{\pi}{3}\right) + \cos\left(\frac{\pi}{6}\right) \cos\left(\frac{\pi}{3}\right) = -2\left(\frac{1}{2}\right)\left(\frac{\sqrt{3}}{2}\right) + \left(\frac{\sqrt{3}}{2}\right)\left(\frac{1}{2}\right) = -\frac{\sqrt{3}}{4}. \end{aligned}$$

Hence, slope of the tangent line is $-\frac{\sqrt{3}}{4}$.

Find the y -coordinate of the tangent point:

$$\text{At } x = \frac{\pi}{6}, y = \sin\left(\frac{\pi}{6}\right) \cos\left(2 \cdot \frac{\pi}{6}\right) = \sin\left(\frac{\pi}{6}\right) \cos\left(\frac{\pi}{3}\right) = \left(\frac{1}{2}\right)\left(\frac{1}{2}\right) = \frac{1}{4} \Rightarrow \text{tangent point is } \left(\frac{\pi}{6}, \frac{1}{4}\right)$$

Using point-slope form for a linear equation, gives

$$y - \frac{1}{4} = -\frac{\sqrt{3}}{4}\left(x - \frac{\pi}{6}\right) \Rightarrow y = -\frac{\sqrt{3}}{4}x + \frac{\pi\sqrt{3}}{24} + \frac{1}{4} \text{ or } y = -\frac{\sqrt{3}}{4}x + \frac{6 + \pi\sqrt{3}}{24}.$$

Therefore, an equation for the line tangent to $y = \sin x \cos(2x)$ at $x = \frac{\pi}{6}$ is

$$y = -\frac{\sqrt{3}}{4}x + \frac{6 + \pi\sqrt{3}}{24}.$$

Our GDC can give a quick visual check for this result. $\left[\frac{\pi}{6} \approx 0.52359878\right]$

```
Plot1 Plot2 Plot3
\Y1= sin(X) cos(2x)
\Y2= (-sqrt(3)/4)X + (6+pi*sqrt(3))/24
\Y3=
\Y4=
\Y5=
```

```
WINDOW
Xmin=-pi/4
Xmax=pi/2
Xscl=1
Ymin=-1.5
Ymax=1
Yscl=1
Xres=1
```

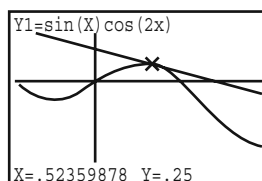

The quotient rule

Just as the derivative of the product of two functions is not the product of their derivatives, the derivative of a quotient of two functions is not the quotient of their derivatives. Let's derive a rule for the quotient of two functions by, once again, returning to the limit definition for the derivative.

Let $y = F(x) = \frac{f(x)}{g(x)}$ where f and g are differentiable functions of x and their quotient is defined for all values of x in the domain.

As with the proof of the product rule we introduce a term, $f(x)g(x)$ in this case, and its opposite (thereby adding zero) in the numerator (in the 3rd line below). This allows us (in the 5th line) to isolate limits that are the derivatives of f and g .

$$\begin{aligned}
 F'(x) &= \lim_{h \rightarrow 0} \frac{\frac{f(x+h)}{g(x+h)} - \frac{f(x)}{g(x)}}{h} \\
 &= \lim_{h \rightarrow 0} \frac{f(x+h)g(x) - f(x)g(x+h)}{h \cdot g(x)g(x+h)} \\
 &= \lim_{h \rightarrow 0} \frac{f(x+h)g(x) - f(x)g(x) + f(x)g(x) - f(x)g(x+h)}{h \cdot g(x)g(x+h)} \\
 &= \lim_{h \rightarrow 0} \frac{g(x) \frac{f(x+h) - f(x)}{h} - f(x) \frac{g(x+h) - g(x)}{h}}{g(x)g(x+h)} \\
 &= \frac{\lim_{h \rightarrow 0} g(x) \cdot \lim_{h \rightarrow 0} \frac{f(x+h) - f(x)}{h} - \lim_{h \rightarrow 0} f(x) \cdot \lim_{h \rightarrow 0} \frac{g(x+h) - g(x)}{h}}{\lim_{h \rightarrow 0} g(x)g(x+h)} \\
 &= \frac{g(x) \cdot f'(x) - f(x) \cdot g'(x)}{g(x)g(x)} \\
 &= \frac{g(x) \cdot f'(x) - f(x) \cdot g'(x)}{[g(x)]^2}
 \end{aligned}$$

The quotient rule

If y is a function in terms of x that can be expressed as the quotient of two functions u and v that are also in terms of x , the quotient $y = \frac{u}{v}$ can be differentiated as follows:

$$\frac{dy}{dx} = \frac{d}{dx} \left(\frac{u}{v} \right) = \frac{v \frac{du}{dx} - u \frac{dv}{dx}}{v^2}$$

or, equivalently, if $y = \frac{f(x)}{g(x)}$, then

$$\frac{dy}{dx} = \frac{d}{dx} \left[\frac{f(x)}{g(x)} \right] = \frac{g(x) \cdot f'(x) - f(x) \cdot g'(x)}{[g(x)]^2}$$

As with the chain rule and the product rule, it is helpful to recognize the structure of the quotient rule by remembering it in words:

$$\left(\begin{array}{c} \text{derivative} \\ \text{of quotient} \end{array} \right) = \frac{(\text{denominator}) \times \left(\begin{array}{c} \text{derivative of} \\ \text{numerator} \end{array} \right) - (\text{numerator}) \left(\begin{array}{c} \text{derivative of} \\ \text{denominator} \end{array} \right)}{(\text{denominator})^2}$$

• **Hint:** Since order is important in subtraction (subtraction is not commutative), be sure to set up the numerator of the quotient rule correctly.

• **Hint:** Note that we could have proved the quotient rule by writing the quotient $\frac{f(x)}{g(x)}$ as the product $f(x)[g(x)]^{-1}$ and apply the product rule and chain rule. As some of the examples here show, the derivative of a quotient can also be found by means of the product rule and/or the chain rule.

Example 7

For each function, find its derivative (i) by the quotient rule, and (ii) by another method.

$$\text{a) } g(x) = \frac{5x-1}{3x^2} \quad \text{b) } h(x) = \frac{1}{2x-3} \quad \text{c) } f(x) = \frac{3x-2}{2x-5}$$

Solution

$$\begin{aligned} \text{a) (i) } g(x) = y &= \frac{u}{v} = \frac{5x-1}{3x^2} \\ g'(x) = \frac{dy}{dx} &= \frac{v \frac{du}{dx} - u \frac{dv}{dx}}{v^2} = \frac{3x^2 \cdot 5 - (5x-1) \cdot 6x}{(3x^2)^2} \\ &= \frac{15x^2 - 30x^2 + 6x}{9x^4} \\ &= \frac{3x(-5x+2)}{9x^4} \\ g'(x) &= \frac{-5x+2}{3x^3} \end{aligned}$$

(ii) Using algebra, 'split' the numerator:

$$g(x) = \frac{5x-1}{3x^2} = \frac{5x}{3x^2} - \frac{1}{3x^2} = \frac{5}{3x} - \frac{1}{3x^2} = \frac{5}{3}x^{-1} - \frac{1}{3}x^{-2}$$

Now, differentiate term-by-term using the power rule.

$$\begin{aligned} g'(x) &= \frac{5}{3} \frac{d}{dx}(-x^{-1}) - \frac{1}{3} \frac{d}{dx}(x^{-2}) \\ &= \frac{5}{3}(-x^{-2}) - \frac{1}{3}(-2x^{-3}) \end{aligned}$$

$$g'(x) = -\frac{5}{3x^2} + \frac{2}{3x^3}$$

[Results for (i) and (ii) are equivalent:

$$-\frac{5}{3x^2} + \frac{2}{3x^3} = -\frac{5}{3x^2} \cdot \frac{x}{x} + \frac{2}{3x^3} = -\frac{5x}{3x^3} + \frac{2}{3x^3} = \frac{-5x+2}{3x^3}]$$

$$\text{b) (i) } y = \frac{f(x)}{g(x)} = \frac{1}{2x-3} \Rightarrow f(x) = 1 \text{ and } g(x) = 2x-3$$

By the quotient rule (function notation form),

$$\begin{aligned} \frac{dy}{dx} &= \frac{d}{dx} \left[\frac{f(x)}{g(x)} \right] = \frac{g(x) \cdot f'(x) - f(x) \cdot g'(x)}{[g(x)]^2} \\ &= \frac{(2x-3) \cdot 0 - 1 \cdot (2)}{(2x-3)^2} \\ \frac{dy}{dx} &= -\frac{2}{(2x-3)^2} \end{aligned}$$

$$\begin{aligned} \text{(ii) } y = f(g(x)) &= \frac{1}{2x-3} = (2x-3)^{-1} \Rightarrow \text{'outside' function is } f(u) = u^{-1} \\ &\Rightarrow f'(u) = -u^{-2} \end{aligned}$$

$$\Rightarrow \text{'inside' function is } g(x) = 2x-3$$

By the chain rule (function notation form),

$$\begin{aligned} \frac{dy}{dx} &= f'(g(x)) \cdot g'(x) = -(2x-3)^{-2} \cdot 2 \\ \frac{dy}{dx} &= -\frac{2}{(2x-3)^2} \end{aligned}$$

$$\begin{aligned}
 \text{c) (i) } f(x) = y = \frac{u}{v} = \frac{3x-2}{2x-5} \quad f'(x) &= \frac{dy}{dx} = \frac{v \frac{du}{dx} - u \frac{dv}{dx}}{v^2} \\
 &= \frac{(2x-5) \cdot 3 - (3x-2) \cdot 2}{(2x-5)^2} \\
 &= \frac{6x-15-6x+4}{(2x-5)^2} \\
 f'(x) &= \frac{-11}{(2x-5)^2}
 \end{aligned}$$

(ii) Rewrite $f(x)$ as a product and apply the product rule (with chain rule imbedded).

$$\begin{aligned}
 f(x) = y = \frac{3x-2}{2x-5} &= (3x-2)(2x-5)^{-1} \Rightarrow y = uv, u = 3x-2 \\
 \text{and } v &= (2x-5)^{-1}
 \end{aligned}$$

Note: $v = (2x-5)^{-1}$ is a composite function, so we'll need the chain rule to find $\frac{dv}{dx}$.

$$\begin{aligned}
 f'(x) &= \frac{d}{dx}(uv) = u \frac{dv}{dx} + v \frac{du}{dx} \\
 &= (3x-2) \cdot \frac{d}{dx}[(2x-5)^{-1}] + (2x-5)^{-1} \cdot 3 \\
 &= (3x-2)[-(2x-5)^{-2} \cdot 2] + 3(2x-5)^{-1} \\
 &\qquad\qquad\qquad \text{Chain rule applied for } \frac{d}{dx}[(2x-5)^{-1}]. \\
 &= (-6x+4)(2x-5)^{-2} + 3(2x-5)^{-1} \\
 &= (2x-5)^{-2}[(-6x+4) + 3(2x-5)] \\
 &\qquad\qquad\qquad \text{Factorizing out GCF of } (2x-5)^2. \\
 &= (2x-5)^{-2}[-6x+4+6x-15] \\
 f'(x) &= \frac{-11}{(2x-5)^2}
 \end{aligned}$$

● **Hint:** The function $h(x) = \frac{3x^2}{5x-1}$ initially looks similar to the function g in Example 7, part a) (they're reciprocals). However, it is *not* possible to 'split' the denominator and express as two fractions. Recognize that $\frac{3x^2}{5x-1}$ is *not* equivalent to $\frac{3x^2}{5x} - \frac{3x^2}{1}$. Hence, in order to differentiate $h(x) = \frac{3x^2}{5x-1}$ we would apply either the quotient rule, or the product rule with the function rewritten as $h(x) = 3x^2(5x-1)^{-1}$ and using the chain rule to differentiate the factor $(5x-1)^{-1}$.

As Example 7 demonstrates, before differentiating a quotient it is worthwhile to consider if performing some algebra may allow other more efficient differentiation techniques to be used.

Higher derivatives

If $y = f(x)$ is a function of x then, in general, the derivative – expressed as either $\frac{dy}{dx}$ or $f'(x)$ – will be some other function of x . As we have learned the derivative indicates the rate of change of $f(x)$ with respect to x , as a function of x . In Section 13.3 we took the 'derivative of the derivative' of a function, that is, a function's second derivative, denoted by $\frac{d^2y}{dx^2}$ or $f''(x)$. The second derivative is an effective tool in verifying maximum, minimum

and inflexion points on the graph of a function. In general, $\frac{d^2y}{dx^2}$ will also be a function of x and so may be differentiated to give the third derivative of y with respect to x , denoted by $\frac{d^3y}{dx^3}$. The n th derivative of y with respect to x is denoted by $\frac{d^ny}{dx^n}$. If the notation $f(x)$ is used, the first, second and third derivatives are written as $f'(x)$, $f''(x)$ and $f'''(x)$, respectively. The fourth derivative and higher is denoted using a superscript number rather than a 'prime' mark. For example, $f^{(4)}(x)$ represents the fourth derivative of the function f with respect to x .

The process of computing the n th derivative of a function can be very tedious and can only be achieved by computing the successive derivatives in turn. It is worthwhile to attempt to simplify the function $\frac{dy}{dx}$ before differentiating to find $\frac{d^2y}{dx^2}$, and in turn try to simplify this result before computing $\frac{d^3y}{dx^3}$, and so on.

Example 8

Given $y = \frac{1}{x}$, find a formula for the n th derivative $\frac{d^ny}{dx^n}$.

Solution

Let's take successive derivatives of the function until we can discern a pattern and then formulate a conjecture for the formula.

$$\begin{aligned} y &= \frac{1}{x} = x^{-1} \\ \frac{dy}{dx} &= -x^{-2} = \frac{-1}{x^2} \\ \frac{d^2y}{dx^2} &= (-2)(-1)x^{-3} = \frac{2}{x^3} \\ \frac{d^3y}{dx^3} &= (-3)(2)(1)x^{-4} = \frac{-6}{x^4} \\ \frac{d^4y}{dx^4} &= (4)(3)(2)(1)x^{-5} = \frac{24}{x^5} \\ \frac{d^5y}{dx^5} &= (-5)(4)(3)(2)(1)x^{-6} = \frac{-120}{x^6} \end{aligned}$$

We observe that the sign of the result alternates: negative when n is odd, and positive when n is even. Thus, we need to incorporate the expression $(-1)^n$ into our formula since the successive values of $(-1)^n$ are $-1, 1, -1, 1, \dots$. Another factor needs to be $n!$ (n factorial) because $n! = n(n-1)(n-2) \cdots 2 \cdot 1$. The last piece of the formula is that the power of x in the denominator is one more than the value of n .

$$\text{Therefore, } \frac{d^{(n)}y}{dx^{(n)}} = \frac{(-1)^n n!}{x^{n+1}}.$$

Exercise 15.1

1 Find the derivative of each function.

- | | | |
|---|----------------------------|-------------------------------|
| a) $y = (3x - 8)^4$ | b) $y = \sqrt{1 - x}$ | c) $y = \sin x \cos x$ |
| d) $y = 2 \sin\left(\frac{x}{2}\right)$ | e) $y = (x^2 + 4)^{-2}$ | f) $y = \frac{x + 1}{x - 1}$ |
| g) $y = \frac{1}{\sqrt{x + 2}}$ | h) $y = \cos^2 x$ | i) $y = x\sqrt{1 - x}$ |
| j) $y = \frac{1}{3x^2 - 5x + 7}$ | k) $y = \sqrt[3]{2x + 5}$ | l) $y = (2x - 1)^3(x^4 + 1)$ |
| m) $y = \frac{\sin x}{x}$ | n) $y = \frac{x^2}{x + 2}$ | o) $y = \sqrt[3]{x^2} \cos x$ |

2 Find the equation of the line tangent to the given curve at the specified value of x . Express the equation exactly in the form $y = mx + c$.

- | | |
|--------------------------------|-------------------------------------|
| a) $y = (2x^2 - 1)^3$ $x = -1$ | b) $y = \sqrt{3x^2 - 2}$ $x = 3$ |
| c) $y = \sin 2x$ $x = \pi$ | d) $y = \frac{x^3 + 1}{2x}$ $x = 1$ |

3 An object moves along a line so that its position s relative to a starting point at any time $t \geq 0$ is given by $s(t) = \cos(t^2 - 1)$.

- Find the velocity of the object as a function of t .
- What is the object's velocity at $t = 0$?
- In the interval $0 < t < 2.5$, find any times (values of t) for which the object is stationary.
- Describe the object's motion during the interval $0 < t < 2.5$.

For questions 4–6, find the equation of a) the tangent, and b) the normal to the curve at the given point.

4 $y = \frac{2}{x^2 - 8}$ at $(3, 2)$

5 $y = \sqrt{1 + 4x}$ at $(2, 3)$

6 $y = \frac{x}{x + 1}$ at $(1, \frac{1}{2})$

7 Consider the trigonometric curve $y = \sin\left(2x - \frac{\pi}{2}\right)$.

- Find $\frac{dy}{dx}$ and $\frac{d^2y}{dx^2}$.
- Find the exact coordinates of any inflexion points for the curve in the interval $0 < x < \pi$.

8 A curve has equation $y = x(x - 4)^2$.

- For this curve, find
 - the x -intercepts
 - the coordinates of the maximum point
 - the coordinates of the point of inflexion.
- Use your answers to part a) to sketch a graph of the curve for $0 \leq x \leq 4$, clearly indicating the features you have found in part a).

9 Consider the function $f(x) = \frac{x^2 - 3x + 4}{(x + 1)^2}$.

- Show that $f'(x) = \frac{5x - 11}{(x + 1)^3}$.
- Show that $f''(x) = \frac{-10x + 38}{(x + 1)^4}$.
- Does the graph of f have an inflexion point at $x = 3.8$? Explain.

- 10** Find the first and second derivatives of the function $f(x) = \frac{x-a}{x+a}$.
- 11** Given $y = \frac{1}{1-x}$, find a formula for the n th derivative $\frac{d^n y}{dx^n}$.
- 12** The graph of the function $g(x) = \frac{8}{4+x^2}$ is called the *witch of Agnesi*.
- Find the exact coordinates of any extreme values or inflexion points.
 - Determine all values of x for which (i) $g(x) < 0$, (ii) $g(x) = 0$, and (iii) $g(x) > 0$.
 - Find (i) $\lim_{x \rightarrow -\infty} g(x)$, and (ii) $\lim_{x \rightarrow +\infty} g(x)$.
 - Sketch the graph of g .
- 13** Use the product rule to prove the constant multiple rule for differentiation. That is, show that $\frac{d}{dx}(c \cdot f(x)) = c \cdot \frac{d}{dx}(f(x))$ for any constant c .
- 14** If $y = x^4 - 6x^2$, show that y , $\frac{dy}{dx}$ and $\frac{d^2y}{dx^2}$ are all negative on the interval $0 < x < 1$, but that $\frac{d^3y}{dx^3}$ is positive on the same interval.

15.2 Derivatives of trigonometric and exponential functions

Although it is important to provide formal justifications for any of our differentiation rules (as we did in the previous section), we should not forget that the derivative is a rule that gives us the slope of the line tangent to the graph of a function at a particular point. Thus, we can use a function's derivative to deduce the behaviour of its graph. Conversely, we can gain insight about the derivative of a function from the shape of its graph.

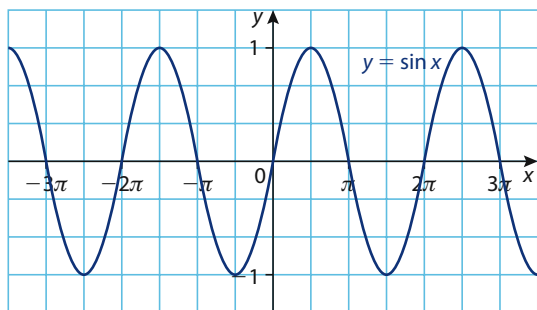

Figure 15.4

In Chapter 13, we formally determined that the derivative of $\sin x$ is $\cos x$ and that the derivative of $\cos x$ is $-\sin x$ by using the limit definition of the derivative. We could have made a very confident conjecture for the derivative of $\sin x$ by analyzing its graph as follows.

We start with the graph of $f(x) = \sin x$ (Figure 15.4). The graph of $y = \sin x$ is periodic, with period 2π , so the same will be true of its derivative that gives the slope at each point on the graph. Therefore, it's only necessary for us to consider the portion of the graph in the interval $0 \leq x \leq 2\pi$.

Figure 15.5 shows two pairs of axes having equal scales on the x - and y -axes and corresponding x -coordinates aligned vertically. On the top pair of axes $y = \sin x$ is graphed with tangent lines drawn at nine selected points. The points were chosen such that the slopes of the tangents at those points, in order, appear to be equal to $1, \frac{1}{2}, 0, -\frac{1}{2}, -1, -\frac{1}{2}, 0, \frac{1}{2}, 1$. The values of these slopes were then plotted in the bottom graph with the y -coordinate

of each point indicating the slope of the curve for that particular x value. Hence, the points in the bottom pair of axes should be on the graph of the derivative of $y = \sin x$.

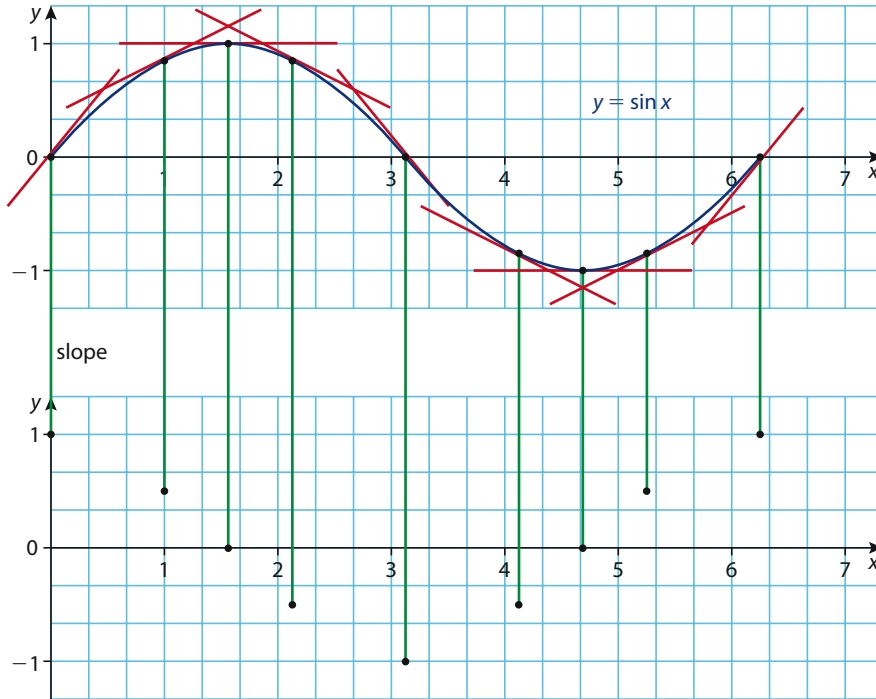

Figure 15.5: Analyzing the slope of tangents to the graph of $y = \sin x$.

Figure 15.6 is the same as Figure 15.5 except with the graph of $y = \sin x$, the grid lines and the lines connecting points between the two graphs removed.

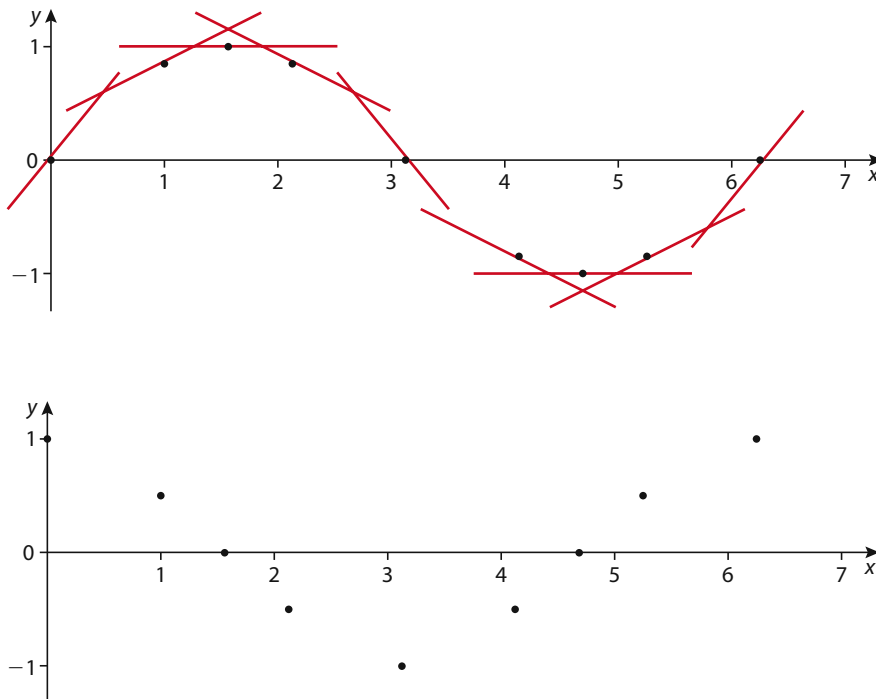

Figure 15.6

Figure 15.7

• **Hint:** Note that the graphs in Figures 15.4, 15.5, 15.6 and 15.7 have x in radians. As mentioned previously, we must only use radian measure when trigonometric functions are involved in calculus.

Clearly the points representing the slope of the tangents to $y = \sin x$ plotted in Figure 15.7 are tracing out the graph of $y = \cos x$.

Although we will use this informal approach to conjecture the derivatives for $y = e^x$ and $y = \ln x$, it does not always work so smoothly. For example, let's analyze the graph of $y = \tan x$ in an attempt to guess its derivative.

We can use our GDC command that evaluates the derivative of a function at a specified point to graph the value of the derivative at all points on a graph. We used this technique in Chapter 13 to confirm the result in Example 9 part d). The GDC screen images below show the graph of $y = \tan x$ and then the GDC graphing its derivative (in bold) on the same set of axes. Although, as pointed out in Section 13.3, in general it is incorrect to graph a function and its derivative on the same pair of axes (units on the vertical axis will not be the same), it is helpful in seeing the connection between the graph of a function and that of its derivative.

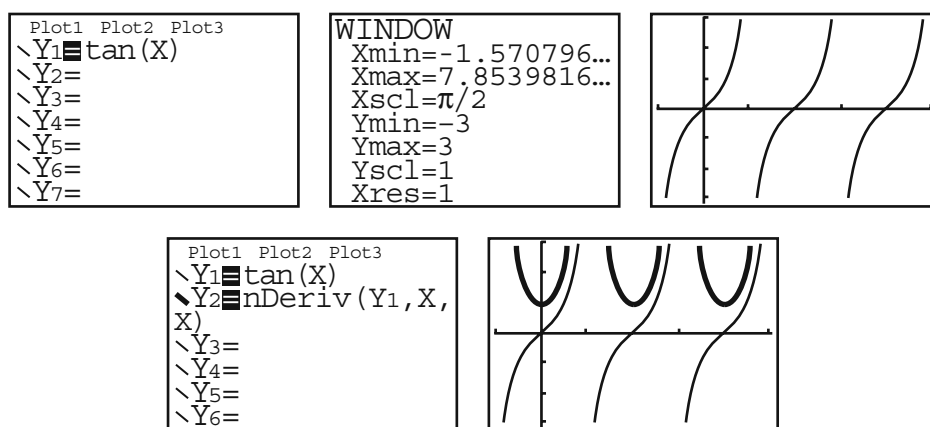

The graph of the derivative of $\tan x$ is always above the x -axis meaning that the derivative is always positive. This clearly agrees with the fact that the tangent function, except for where it is undefined, is always increasing (moving upwards) as the values of x increase. However, the shape of the graph does not bring to mind an easy conjecture for a rule for the derivative of $\tan x$.

Rather than use the limit definition for finding the derivative of $\tan x$ let's write $\tan x$ as $\frac{\sin x}{\cos x}$ and use the quotient rule.

$$\begin{aligned} \frac{d}{dx}(\tan x) &= \frac{d}{dx}\left(\frac{\sin x}{\cos x}\right) = \frac{\cos x \frac{d}{dx}(\sin x) - \sin x \frac{d}{dx}(\cos x)}{\cos^2 x} \\ &= \frac{\cos x \cos x - \sin x(-\sin x)}{\cos^2 x} \\ &= \frac{\cos^2 x + \sin^2 x}{\cos^2 x} \\ &= \frac{1}{\cos^2 x} \\ &= \sec^2 x \end{aligned} \quad \text{Therefore, } \frac{d}{dx}(\tan x) = \sec^2 x.$$

Similarly, it can be shown that $\frac{d}{dx}(\cot x) = -\csc^2 x$.

To find the derivative of $\sec x$ we can use the chain rule as follows.

$$\begin{aligned} \frac{d}{dx}(\sec x) &= \frac{d}{dx}\left(\frac{1}{\cos x}\right) = \frac{d}{dx}[(\cos x)^{-1}] \\ &= -(\cos x)^{-2}(-\sin x) && \text{Applying chain rule.} \\ &= \frac{\sin x}{\cos^2 x} \\ &= \frac{1}{\cos x} \cdot \frac{\sin x}{\cos x} \\ &= \sec x \tan x \end{aligned}$$

Therefore, $\frac{d}{dx}(\sec x) = \sec x \tan x$.

Similarly, it can be shown that $\frac{d}{dx}(\csc x) = -\csc x \cot x$.

The table below lists the derivatives of the six trigonometric functions.

$f(x)$	$f'(x)$
$\sin x$	$\cos x$
$\cos x$	$-\sin x$
$\tan x$	$\sec^2 x$
$\cot x$	$-\csc^2 x$
$\sec x$	$\sec x \tan x$
$\csc x$	$-\csc x \cot x$

Example 9

Find the derivative of each function.

- a) $y = \cos(\sqrt{x})$ b) $y = \frac{x^3}{\sin x}$
 c) $y = x^2 \tan(3x)$ d) $y = \sec^2(3x)$

Solution

a) $\frac{dy}{dx} = \frac{d}{dx}[\cos(\sqrt{x})] = -\sin(\sqrt{x}) \cdot \frac{d}{dx}(\sqrt{x})$ Applying chain rule.

$$= -\sin(\sqrt{x}) \cdot \frac{d}{dx}(x^{\frac{1}{2}})$$

$$= -\sin(\sqrt{x}) \cdot \left(\frac{1}{2}x^{-\frac{1}{2}}\right)$$
 Applying power rule.

Therefore, $\frac{dy}{dx} = -\frac{\sin(\sqrt{x})}{2\sqrt{x}}$.

b) Method 1 (quotient rule):

$$\frac{dy}{dx} = \frac{d}{dx}\left(\frac{x^3}{\sin x}\right) = \frac{\sin x \cdot \frac{d}{dx}(x^3) - x^3 \cdot \frac{d}{dx}(\sin x)}{\sin^2 x}$$
 Applying quotient rule.

Therefore, $\frac{dy}{dx} = \frac{3x^2 \sin x - x^3 \cos x}{\sin^2 x}$.

Method 2 (product rule and chain rule):

$$\begin{aligned}\frac{dy}{dx} &= \frac{d}{dx}\left(\frac{x^3}{\sin x}\right) = \frac{d}{dx}[x^3 \cdot (\sin x)^{-1}] && \text{Rewriting as a product.} \\ &= x^3 \cdot \frac{d}{dx}[(\sin x)^{-1}] + (\sin x)^{-1} \cdot \frac{d}{dx}(x^3) && \text{Applying product rule.} \\ &= x^3[-(\sin x)^{-2} \cos x] + (\sin x)^{-1}(3x^2) \\ &= (\sin x)^{-2}[-x^3 \cos x + 3x^2 \sin x] && \text{Factor out common factor of } (\sin x)^{-2}.\end{aligned}$$

$$\text{Therefore, } \frac{dy}{dx} = \frac{3x^2 \sin x - x^3 \cos x}{\sin^2 x}.$$

$$\begin{aligned}\text{c) } \frac{dy}{dx} &= \frac{d}{dx}[x^2 \tan(3x)] = x^2 \cdot \frac{d}{dx}(\tan(3x)) + \tan(3x) \cdot \frac{d}{dx}(x^2) \\ &= x^2 \cdot \frac{d}{dx}(\tan(3x)) + \tan(3x) \cdot \frac{d}{dx}(x^2) && \text{Applying product rule.} \\ &= x^2(3 \sec^2(3x)) + (\tan(3x))(2x) && \text{Applying chain rule for } \frac{d}{dx}(\tan(3x)). \\ &= 3x^2 \sec^2(3x) + 2x \tan(3x)\end{aligned}$$

$$\begin{aligned}\text{d) } \frac{dy}{dx} &= \frac{d}{dx}[\sec^2(3x)] = \frac{d}{dx}[(\sec(3x))^2] \\ &= 2 \sec(3x) \cdot \frac{d}{dx}(\sec(3x)) && \text{Applying chain rule 1st time.} \\ &= 2 \sec(3x) \cdot (\sec(3x)\tan(3x) \cdot \frac{d}{dx}(3x)) && \text{Applying chain rule 2nd time.} \\ &= 2 \sec(3x) \cdot (\sec(3x)\tan(3x) \cdot 3) \\ &= 6 \sec^2(3x)\tan(3x) && \text{Equivalent to } \frac{6 \sin(3x)}{\cos^3(3x)}.\end{aligned}$$

Example 10

The motion of a particle moving along a straight line for the interval $0 < t < 12$ (t in seconds) is given by the function $s(t) = \sin\left(\frac{t}{2}\right) - \cos\left(\frac{t}{2}\right) + 1$, where s is the particle's displacement in centimetres from the origin O . The particle's displacement is negative when left of O and positive when right of O .

- Find the exact time and displacement when the particle is (i) furthest to the right and (ii) furthest to the left during the interval $0 < t < 12$.
- Find the particle's maximum speed to the right exactly and at what exact time it occurs.

Solution

For part a) displacement can only be a maximum or minimum when velocity is zero, i.e. $v(t) = 0$. Similarly for part b) velocity can only be a maximum or minimum when acceleration is zero, i.e. $a(t) = 0$. So we begin by finding the first and second derivatives of $s(t)$ giving us the velocity function, $v(t)$, and acceleration function, $a(t)$, respectively.

$$\text{a) } v(t) = s'(t) = \frac{d}{dx} \left[\sin\left(\frac{t}{2}\right) - \cos\left(\frac{t}{2}\right) + 1 \right] = \frac{1}{2} \cos\left(\frac{t}{2}\right) + \frac{1}{2} \sin\left(\frac{t}{2}\right)$$

$$\text{Solve } \frac{1}{2} \cos\left(\frac{t}{2}\right) + \frac{1}{2} \sin\left(\frac{t}{2}\right) = 0:$$

$$\sin\left(\frac{t}{2}\right) = -\cos\left(\frac{t}{2}\right)$$

$$\frac{\sin\left(\frac{t}{2}\right)}{\cos\left(\frac{t}{2}\right)} = \tan\left(\frac{t}{2}\right) = -1 \quad \text{Given that } \cos\left(\frac{t}{2}\right) \neq 0.$$

$$\tan\left(\frac{t}{2}\right) = -1 \text{ when } \frac{t}{2} = \frac{3\pi}{4} + k \cdot \pi, k \in \mathbb{Z}$$

$$\text{Thus, } t = \frac{3\pi}{2} + k \cdot 2\pi, k \in \mathbb{Z}. \text{ For } 0 < t < 12, t = \frac{3\pi}{2} \text{ or } t = \frac{7\pi}{2}.$$

- (i) Checking the sign (direction) of the particle's velocity just before and after these two times will show if they are maximum or minimum values. Test values are $t = \pi$ and 2π for $t = \frac{3\pi}{2}$.

$$v(\pi) = \frac{1}{2} \cos\left(\frac{\pi}{2}\right) + \frac{1}{2} \sin\left(\frac{\pi}{2}\right) = 0 + \frac{1}{2} \cdot 1 = \frac{1}{2} > 0 \Rightarrow \text{displacement increasing before } t = \frac{3\pi}{2}$$

$$v(2\pi) = \frac{1}{2} \cos\left(\frac{2\pi}{2}\right) + \frac{1}{2} \sin\left(\frac{2\pi}{2}\right) = \frac{1}{2}(-1) + 0 < 0 \Rightarrow \text{displacement decreasing before } t = \frac{3\pi}{2}$$

$$\text{Hence, } s\left(\frac{3\pi}{2}\right) = \sin\left(\frac{3\pi}{4}\right) - \cos\left(\frac{3\pi}{4}\right) + 1 = \frac{\sqrt{2}}{2} - \left(-\frac{\sqrt{2}}{2}\right) + 1 = 1 + \sqrt{2} \text{ is a maximum.}$$

Therefore, the particle is furthest to the right (maximum displacement) at $t = \frac{3\pi}{2}$ seconds when its displacement is $1 + \sqrt{2}$ cm.

- (ii) Test values are $t = 3\pi$ and 4π for $t = \frac{7\pi}{2}$.

$$v(3\pi) = \frac{1}{2} \cos\left(\frac{3\pi}{2}\right) + \frac{1}{2} \sin\left(\frac{3\pi}{2}\right) = 0 + \frac{1}{2}(-1) < 0 \Rightarrow \text{displacement decreasing before } t = \frac{7\pi}{2}$$

$$v(4\pi) = \frac{1}{2} \cos(2\pi) + \frac{1}{2} \sin(2\pi) = \frac{1}{2}(1) + 0 > 0 \Rightarrow \text{displacement increasing after } t = \frac{7\pi}{2}$$

$$\text{Hence, } s\left(\frac{7\pi}{2}\right) = \sin\left(\frac{7\pi}{4}\right) - \cos\left(\frac{7\pi}{4}\right) + 1 = -\frac{\sqrt{2}}{2} - \left(\frac{\sqrt{2}}{2}\right) + 1 = 1 - \sqrt{2} \text{ is a minimum.}$$

Therefore, the particle is furthest to the left (minimum displacement) at $t = \frac{7\pi}{2}$ seconds when its displacement is $1 - \sqrt{2}$ cm.

$$\text{b) } a(t) = v'(t) = \frac{d}{dx} \left[\frac{1}{2} \cos\left(\frac{t}{2}\right) + \frac{1}{2} \sin\left(\frac{t}{2}\right) \right] = -\frac{1}{4} \sin\left(\frac{t}{2}\right) + \frac{1}{4} \cos\left(\frac{t}{2}\right)$$

$$\text{Solve } \frac{1}{4} \cos\left(\frac{t}{2}\right) - \frac{1}{4} \sin\left(\frac{t}{2}\right) = 0:$$

$$\sin\left(\frac{t}{2}\right) = \cos\left(\frac{t}{2}\right)$$

$$\frac{\sin\left(\frac{t}{2}\right)}{\cos\left(\frac{t}{2}\right)} = \tan\left(\frac{t}{2}\right) = 1 \quad \text{Given that } \cos\left(\frac{t}{2}\right) \neq 0.$$

$$\tan\left(\frac{t}{2}\right) = 1 \text{ when } \frac{t}{2} = \frac{\pi}{4} + k \cdot \pi, k \in \mathbb{Z}$$

$$\text{Thus, } t = \frac{\pi}{2} + k \cdot 2\pi, k \in \mathbb{Z}. \text{ For } 0 < t < 12, t = \frac{\pi}{2} \text{ or } t = \frac{5\pi}{2}.$$

To find maximum velocity (moving right, speed > 0), let's evaluate the velocity at all critical points, i.e. at endpoints for the time interval, $t = 0$ and $t = 12$, and where the acceleration is zero, $t = \frac{\pi}{2}$ and $t = \frac{5\pi}{2}$.

$$v(0) = \frac{1}{2} \cos(0) + \frac{1}{2} \sin(0) = \frac{1}{2}$$

$$v\left(\frac{\pi}{2}\right) = \frac{1}{2} \cos\left(\frac{\pi}{4}\right) + \frac{1}{2} \sin\left(\frac{\pi}{4}\right) = \frac{\sqrt{2}}{4} + \frac{\sqrt{2}}{4} = \frac{\sqrt{2}}{2} \approx 0.707$$

$$v\left(\frac{5\pi}{2}\right) = \frac{1}{2} \cos\left(\frac{5\pi}{4}\right) + \frac{1}{2} \sin\left(\frac{5\pi}{4}\right) = -\frac{\sqrt{2}}{4} - \frac{\sqrt{2}}{4} = -\frac{\sqrt{2}}{2} \approx -0.707$$

$$v(12) = \frac{1}{2} \cos(6) + \frac{1}{2} \sin(6) \approx -0.424$$

Therefore, the particle has a maximum velocity of $\frac{\sqrt{2}}{2}$ cm/sec when $t = \frac{\pi}{2}$ seconds.

A graph of the displacement function $s(t) = \sin\left(\frac{t}{2}\right) - \cos\left(\frac{t}{2}\right) + 1$ gives a good visual confirmation of our results.

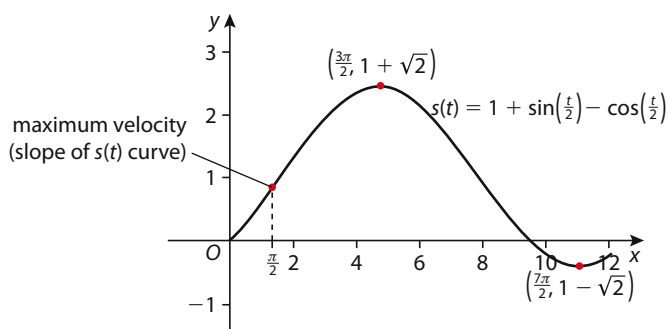

Derivatives of exponential functions

Let's review some important facts about exponential functions in general. An exponential function with base b is defined as $f(x) = b^x$, $b > 0$ and $b \neq 1$. The graph of f passes through $(0, 1)$, has the x -axis as a horizontal asymptote, and, depending on the value of the base of the exponential function b , will either be a continually increasing exponential growth curve (Figure 15.8) or a continually decreasing exponential decay curve (Figure 15.9).

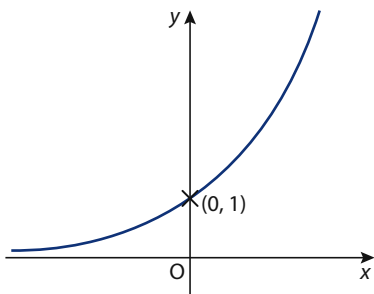

Figure 15.8

as $x \rightarrow \infty, f(x) \rightarrow \infty$
 f is an increasing function
exponential growth curve

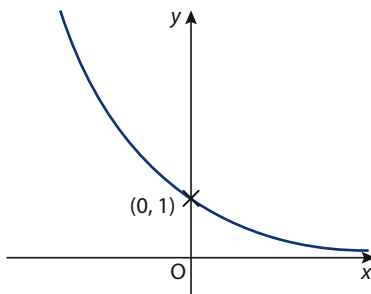
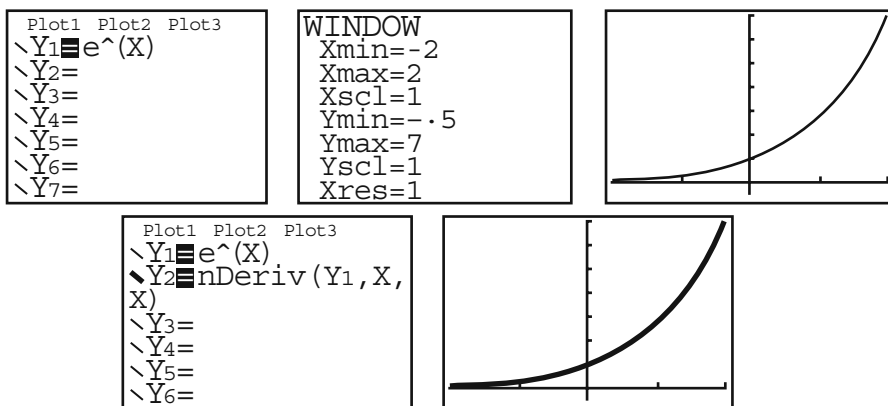

Figure 15.9

as $x \rightarrow \infty, f(x) \rightarrow 0$
 f is a decreasing function
exponential decay curve

In Chapter 5 we learned that *the* exponential function e^x , sometimes written as 'exp x ', is a particularly important function for modelling exponential growth and decay. The number e was defined in Section 5.3 as the limit of $\left(1 + \frac{1}{x}\right)^x$ as $x \rightarrow \infty$. Although the method was not successful in coming up with a conjecture for the derivative of the tangent function, let's try to guess the derivative of e^x by having our GDC graph its derivative.



The graph of the derivative of e^x appears to be identical to e^x itself! This is a very interesting result, but one which we will see fits in exactly with the nature of exponential growth/decay.

Let's try to apply the limit definition of the derivative to provide a formal justification.

$$\frac{d}{dx}(e^x) = \lim_{h \rightarrow 0} \frac{e^{x+h} - e^x}{h}$$

$$= \lim_{h \rightarrow 0} \frac{e^x \cdot e^h - e^x}{h}$$

$$= \lim_{h \rightarrow 0} \frac{e^x(e^h - 1)}{h}$$

$$= \lim_{h \rightarrow 0} e^x \cdot \lim_{h \rightarrow 0} \frac{(e^h - 1)}{h}$$

$$= e^x \cdot \lim_{h \rightarrow 0} \frac{e^h - 1}{h}$$

Applying limit definition $f'(x) = \lim_{h \rightarrow 0} \frac{f(x+h) - f(x)}{h}$.

Reverse of law of exponents: $a^m \cdot a^n = a^{m+n}$.

Factorizing.

Applying properties of limits.

e^x is not affected by the value of h .

Hint: You may be tempted to find the derivative of e^x by applying the rule for differentiating powers $\frac{d}{dx}(x^n) = nx^{n-1}$ but this *only* applies if a variable is raised to a constant power. An exponential function, such as $y = e^x$, is a constant raised to a variable power, so the power rule does *not* apply.

A closer look at the limit that is multiplying e^x reveals that it is equivalent to the slope of the graph of $y = e^x$ at $x = 0$: $\lim_{h \rightarrow 0} \frac{e^{0+h} - e^0}{h} = \lim_{h \rightarrow 0} \frac{e^h - 1}{h}$. To finish our differentiation of e^x by first principles, we need to evaluate this limit. It is beyond the scope of this course to give a formal algebraic proof for the limit. Nevertheless, we can provide a convincing informal justification by evaluating the expression $\frac{e^h - 1}{h}$ for values of h approaching zero, as shown in the table.

h	$\frac{e^h - 1}{h}$
0.1	1.051 709 181
0.01	1.005 016 708
0.0001	1.000 050 002
0.000 001	1.000 000 005

Thus, $\lim_{h \rightarrow 0} \frac{e^h - 1}{h} = 1$ and we can complete our algebraic work for the derivative of e^x .

$$\frac{d}{dx}(e^x) = e^x \cdot \lim_{h \rightarrow 0} \frac{e^h - 1}{h} = e^x \cdot 1 = e^x$$

The derivative of the exponential function is the exponential function. More precisely, the slope of the graph of $f(x) = e^x$ at any point (x, e^x) is equal to the y -coordinate of the point.

The derivative of the exponential function

If $f(x) = e^x$, then $f'(x) = e^x$. Or, in Leibniz notation, $\frac{d}{dx}(e^x) = e^x$.

Example 11

Differentiate each of the following functions.

a) $y = e^{2x + \ln x}$ b) $y = \sqrt{x^2 + e^{4x}}$ c) $y = \frac{e^x - e^{-x}}{e^x + e^{-x}}$

Solution

a) Because $e^{2x + \ln x} = e^{2x}e^{\ln x}$ and $e^{\ln x} = x$, then $e^{2x + \ln x} = xe^{2x}$.

$$\begin{aligned} \frac{dy}{dx} &= \frac{d}{dx}(e^{2x + \ln x}) = \frac{d}{dx}(xe^{2x}) \\ &= x \cdot \frac{d}{dx}(e^{2x}) + e^{2x} \cdot \frac{d}{dx}(x) \quad \text{Applying the product rule.} \end{aligned}$$

$$\text{Therefore, } \frac{dy}{dx} = 2xe^{2x} + e^{2x}.$$

$$\begin{aligned} \text{b) } \frac{dy}{dx} &= \frac{d}{dx}(\sqrt{x^2 + e^{4x}}) = \frac{d}{dx}[(x^2 + e^{4x})^{\frac{1}{2}}] \\ &= \frac{1}{2}(x^2 + e^{4x})^{-\frac{1}{2}} \cdot \frac{d}{dx}(x^2 + e^{4x}) \quad \text{Applying power rule and chain rule.} \\ &= \frac{2x + 4e^{4x}}{2\sqrt{x^2 + e^{4x}}} \end{aligned}$$

$$\text{Therefore, } \frac{dy}{dx} = \frac{x + 2e^{4x}}{\sqrt{x^2 + e^{4x}}}.$$

$$\begin{aligned}
\text{c) } \frac{dy}{dx} &= \frac{d}{dx} \left(\frac{e^x - e^{-x}}{e^x + e^{-x}} \right) \\
&= \frac{(e^x + e^{-x}) \cdot \frac{d}{dx}(e^x - e^{-x}) - (e^x - e^{-x}) \cdot \frac{d}{dx}(e^x + e^{-x})}{(e^x + e^{-x})^2} && \text{Quotient rule.} \\
&= \frac{(e^x + e^{-x})(e^x + e^{-x}) - (e^x - e^{-x})(e^x - e^{-x})}{(e^x + e^{-x})^2} \\
&= \frac{(e^{2x} + 2e^x e^{-x} + e^{-2x}) - (e^{2x} - 2e^x e^{-x} + e^{-2x})}{(e^x + e^{-x})^2} \\
&= \frac{4e^x e^{-x}}{(e^x + e^{-x})^2} \\
\text{Therefore, } \frac{dy}{dx} &= \frac{4}{(e^x + e^{-x})^2}.
\end{aligned}$$

What about exponential functions with bases other than e ? We now differentiate the general exponential function $f(x) = b^x$, $b > 1$, $b \neq 0$, repeating the same steps we did with $f(x) = e^x$.

$$\begin{aligned}
\frac{d}{dx}(b^x) &= \lim_{h \rightarrow 0} \frac{b^{x+h} - b^x}{h} && \text{Definition of derivative.} \\
&= \lim_{h \rightarrow 0} \frac{b^x \cdot b^h - b^x}{h} && \text{Reverse of } a^m \cdot a^n = a^{m+n}. \\
&= \lim_{h \rightarrow 0} \frac{b^x(b^h - 1)}{h} && \text{Factorizing.} \\
&= b^x \cdot \lim_{h \rightarrow 0} \frac{b^h - 1}{h} && b^x \text{ is not affected by the value of } h.
\end{aligned}$$

As with e^x , $\lim_{h \rightarrow 0} \frac{b^h - 1}{h}$ is equivalent to the slope of the graph of $f(x) = b^x$ at $x = 0$, i.e. $f'(0)$. Therefore, the derivative of the general exponential function $f(x) = b^x$ is $b^x \cdot f'(0)$. Although the value of $f'(0)$ will be a constant, it will depend on the value of the base b .

Application of the chain rule gives us the means to determine the value of $f'(0)$ in terms of b for the function $f(x) = b^x$. We can then state the rule for the derivative of the general exponential function $f(x) = b^x$.

We can use the laws of logarithms to write b^x in terms of e^x . Recall from Section 5.5 that $b^{\log_b x} = x$, and if $b = e$ then $e^{\ln x} = x$. Hence, $b^x = e^{x \ln b}$ because $e^{x \ln b} = e^{\ln(b^x)} = b^x$. We can now find the derivative of b^x by applying the chain rule to its equivalent expression $e^{x \ln b}$.

$$\begin{aligned}
y &= f(g(x)) = e^{x \ln b} \Rightarrow \text{'outside' function is } f(u) = e^u \\
f'(u) &= e^u \Rightarrow \text{'inside' function is } g(x) = x \ln b \\
g'(x) &= \ln b \text{ [} \ln b \text{ is a constant]} \\
\frac{dy}{dx} &= f(g(x)) \cdot g'(x) = e^{x \ln b} \cdot \ln b \\
\frac{dy}{dx} &= b^x \ln b
\end{aligned}$$

Therefore, $\frac{d}{dx}(b^x) = b^x \ln b$.

This result agrees with the fact that $\frac{d}{dx}(e^x) = e^x$. Using this 'new' general rule, $\frac{d}{dx}(b^x) = b^x \ln b$, then $\frac{d}{dx}(e^x) = e^x \ln e$. Since $\ln e = 1$ then $\frac{d}{dx}(e^x) = e^x$.

• **Hint:** Be careful to distinguish between the power rule,

$\frac{d}{dx}(x^n) = nx^{n-1}$, where the base is a variable and the exponent is a constant, and the rule for differentiating exponential

functions, $\frac{d}{dx}(b^x) = b^x \ln b$, where the base is a constant and the exponent is a variable.

The derivative of the general exponential function

For $b > 0$ and $b \neq 1$, if $f(x) = b^x$, then $f'(x) = b^x \ln b$. Or, in Leibniz notation,

$$\frac{d}{dx}(b^x) = b^x \ln b.$$

Earlier we established that the derivative of the general exponential function $f(x) = b^x$ is $b^x \cdot f'(0)$, where $f'(0)$ is the slope of the graph at $x = 0$. From our result above, we can see that for a specific base b the slope of the curve $y = b^x$ when $x = 0$ is $\ln b$ because $b^0 \ln b = \ln b$. The first GDC screen image below shows the value of $f'(0)$ for $b = 2, 3$ and $\frac{1}{2}$. Evaluating $\ln 2, \ln 3$ and $\ln(\frac{1}{2})$ confirms that $f'(0)$ is equal to $\ln b$.

```
nDeriv(2^X,X,0)
.6931472361
nDeriv(3^X,X,0)
1.09861251
nDeriv((1/2)^X,X
,0)
-.6931472361
```

```
ln(2)
.6931471806
ln(3)
1.098612289
ln(1/2)
-.6931471806
```

Example 12

Find the equation of the line tangent to the curve $y = 2^x$ at the point where $x = 3$. Express the equation of the line exactly in the form $y = mx + c$.

Solution

We first find the derivative of $y = 2^x$ and then evaluate it at $x = 3$ to get the slope of the tangent.

$$y' = \frac{d}{dx}(2^x) = 2^x(\ln 2) \Rightarrow y'(3) = 2^3(\ln 2) = 8 \ln 2 = \ln 2^8 \\ = \ln 256 \Rightarrow m = \ln 256$$

Finding the y -coordinate of the tangent point, $y(3) = 2^3 = 8 \Rightarrow$ point is $(3, 8)$

Substituting into the point-slope form for a linear equation, gives

$$y - y_1 = m(x - x_1) \Rightarrow y - 8 = \ln 256(x - 3)$$

Therefore, the equation of the tangent line is $y = (\ln 256)x + 8 - 3 \ln 256$.

The GDC images below nicely confirm the result.

```
Plot1 Plot2 Plot3
\Y1=2^X
\Y2=(ln(256))X+8
-3ln(256)
\Y3=
\Y4=
\Y5=
\Y6=
```

```
WINDOW
Xmin=-1
Xmax=5
Xscl=1
Ymin=-5
Ymax=20
Yscl=5
Xres=1
```

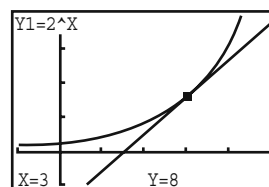

Example 13

Find the coordinates of the point P lying on the graph of $y = 5^x$ such that the line tangent to the curve at P passes through the origin.

Solution

Let $P = (x_0, y_0)$ be a point on the graph of $y = 5^x$. Since $\frac{dy}{dx} = 5^x(\ln 5)$

the slope of the tangent line to the curve at P is given by $\frac{dy}{dx} = 5^{x_0}(\ln 5)$.

Substituting into the point-slope form for a linear equation gives,

$$y - y_0 = 5^{x_0}(\ln 5)(x - x_0)$$

If the line passes through the origin then $(0, 0)$ must satisfy the equation.

$$0 - y_0 = 5^{x_0}(\ln 5)(0 - x_0) \Rightarrow -y_0 = 5^{x_0}(\ln 5)(-x_0)$$

But $y_0 = 5^{x_0}$, so $-5^{x_0} = 5^{x_0}(\ln 5)(-x_0) \Rightarrow x_0 = \frac{5^{x_0}}{5^{x_0} \ln 5} = \frac{1}{\ln 5}$.

Then $y_0 = 5^{\frac{1}{\ln 5}} \Rightarrow (y_0)^{\ln 5} = \left(5^{\frac{1}{\ln 5}}\right)^{\ln 5} \Rightarrow (y_0)^{\ln 5} = 5 \Rightarrow y_0 = e$ because $e^{\ln x} = x$.

Therefore, the point P on the graph of $y = 5^x$ has coordinates $\left(\frac{1}{\ln 5}, e\right)$.

As a check let's find the equation of the tangent to $y = 5^x$ at this point.

Since $\frac{dy}{dx} = 5^{x_0}(\ln 5)$ the slope is $5^{\frac{1}{\ln 5}}(\ln 5)$, but we showed above that

$5^{\frac{1}{\ln 5}} = e$. So the slope is equivalent to $e \ln 5$. Substituting in the point-slope

form gives $y - e = e \ln 5 \left(x - \frac{1}{\ln 5}\right) \Rightarrow y = e(\ln 5)x$. Clearly this line passes through $(0, 0)$.

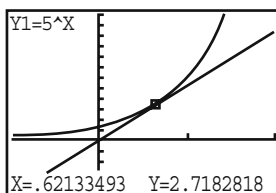
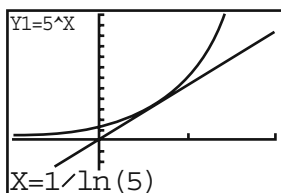
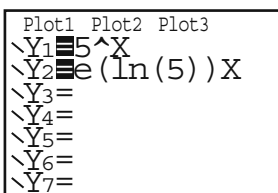

If $f(x) = b^x$, then $f'(x) = b^x \cdot f'(0)$. The value of $f'(0)$ is the slope of the graph of $f(x) = b^x$ at the point $(0, 1)$. Hence, this will be a particular constant for each value of b ($b > 1, b \neq 0$). Therefore, if $f(x) = b^x$, then $f'(x) = kb^x$ where k is a constant dependent on the value of b . If the amount of a quantity y at a time t is given by $y = b^t$ then $\frac{dy}{dt} = kb^t = ky$. In other words, the rate of change of the quantity y at time t is proportional to the amount of y at time t . This is the essential behaviour of exponential growth/decay. It is because of this property that exponential functions have so many applications to real-life phenomena. Here are some good examples:

- 1 The rate of population growth for many living organisms is proportional to the size of the population p : $\frac{dp}{dt} = kp$.
- 2 The rate at which a radioactive substance decays is proportional to the amount A of the substance present: $\frac{dA}{dt} = kA$.
- 3 Newton's law of cooling states that if a substance is placed in cooler surroundings then its temperature decreases at a rate proportional to the temperature difference T between the temperature of the substance and the temperature of its surroundings: $\frac{dT}{dt} = kT$.

Exercise 15.2

1 Find the derivative of each function.

a) $y = x^2 e^x$

b) $y = 8^x$

c) $y = \tan e^x$

d) $y = \frac{x}{1 + \cos x}$

e) $y = \frac{e^x}{x}$

f) $y = \frac{1}{3} \sec^3 2x - \sec 2x$

g) $y = 4^{-x}$

h) $y = \cos x \tan x$

i) $y = \frac{x}{e^x - 1}$

j) $y = 4 \cos(\sin 3x)$

k) $y = 2^{x+1}$

l) $y = \frac{1}{\csc x - \sec x}$

2 Find the equation of the line tangent to the given curve at the specified value of x . Express the equation exactly in the form $y = mx + c$.

a) $y = \sin x$ $x = \frac{\pi}{3}$

b) $y = x + e^x$ $x = \frac{\pi}{3}$

c) $y = 4 \tan 2x$ $x = \frac{\pi}{8}$

3 Consider the function $g(x) = x + 2 \cos x$. For the interval $0 \leq x \leq 2\pi$.

a) find the exact x -coordinates of any stationary points

b) determine whether each stationary point is a maximum, minimum or neither and give a brief explanation.

4 Find the coordinates of any stationary points on the curve $y = x - e^x$. Classify any such points as a maximum, minimum or neither and explain.

5 Find the coordinates of any stationary points for each function on the interval $0 \leq x \leq 2\pi$. Indicate whether a stationary point is a maximum, minimum or neither.

a) $f(x) = 4 \sin x - \cos 2x$

b) $g(x) = \tan x(\tan x + 2)$

6 Find the equation of the normal line to the curve $y = 3 + \sin x$ at the point where $x = \frac{\pi}{2}$.

7 Consider the function $f(x) = e^x - x^3$.

a) Find $f'(x)$ and $f''(x)$.

b) Find the x -coordinates (accurate to three significant figures) for any points where $f'(x) = 0$.

c) Indicate the intervals for which $f(x)$ is increasing, and indicate the intervals for which $f(x)$ is decreasing.

d) For the values of x found in part b), state whether that point on the graph of f is a maximum, minimum or neither.

e) Find the x -coordinate of any inflexion point(s) for the graph of f .

f) Indicate the intervals for which $f(x)$ is concave up, and indicate the intervals for which $f(x)$ is concave down.

8 Show that the curves $y = e^{-x}$ and $y = e^{-x} \cos x$ are tangent at each point common to both curves. Sketch the two curves over the interval $-\frac{\pi}{2} \leq x \leq \frac{3\pi}{2}$.

9 A particle moves in a straight line such that its displacement, s metres, is given by $s(t) = 4 \cos t - \cos 2t$. If the particle comes to rest after T seconds, where $T > 0$, find:

a) the particle's acceleration at time T

b) the maximum speed of the particle for $0 < t < T$.

10 Find an equation for a line that is tangent to the graph of $y = e^x$ that passes through the origin.

- 11** Consider the exponential function $f(x) = 2^x$.
- Find $f'(x)$.
 - Find the equation of the tangent to the graph of f at the point $(0, 1)$.
 - Explain why the graph of f has no stationary points.
- 12** Consider the function $h(x) = \frac{x^2 - 3}{e^x}$.
- Find the exact coordinates of any stationary points.
 - Determine whether each stationary point is a maximum, minimum or neither.
 - What do the function values approach as (i) $x \rightarrow \infty$ and (ii) $x \rightarrow -\infty$.
 - Write down the equation of any asymptotes for the graph of $h(x)$.
 - Make an accurate sketch of the curve indicating any extrema and points where the graph intersects the x - and y -axis.
- 13** Given $y = \sin x$, and $\frac{dy}{dx} = \sin(x + a)$, $\frac{d^2y}{dx^2} = \sin(x + b)$ and $\frac{d^3y}{dx^3} = \sin(x + c)$, find:
- the values of a , b and c
 - a formula for $\frac{d^{(n)}y}{dx^{(n)}}$.
- 14** a) Find the first three derivatives of $y = xe^x$.
- Suggest a formula for $\frac{d^{(n)}}{dx^{(n)}}(xe^x)$ that is true for all positive integers n .
 - Prove that your formula is true by using mathematical induction.

15.3

Implicit differentiation, logarithmic functions and inverse trigonometric functions

Implicit differentiation

An equation such as $3x - 2y - 8 = 0$ is said to define y as a function of x because it satisfies the definition of a function in that each value of x (domain) determines (corresponds to) a unique value of y (range). We can manipulate the equation in order to solve for y in terms of x , giving $y = \frac{3}{2}x - 4$. In this form, in which y is alone on one side of the equation, the equation is said to define y **explicitly** as a function of x . In the original form of the equation, $x - 2y - 8 = 0$, the function is said to define y **implicitly** as a function of x . If we wish to find the derivative of y with respect to x , $\frac{dy}{dx}$, from an equation in which y is defined implicitly as a function of x we can often solve for y and then differentiate using one of the rules that we have established. For example, if we were asked to find $\frac{dy}{dx}$ for the equation $xy = 1$ we can write y explicitly as a function of x and then differentiate.

$$xy = 1 \Rightarrow y = \frac{1}{x} = x^{-1} \Rightarrow \frac{dy}{dx} = \frac{d}{dx}(x^{-1}) = -x^{-2} = -\frac{1}{x^2}$$

Most of the functions that we have encountered thus far can be described by expressing one variable explicitly in terms of another variable – for

example, $y = \cos(2x)$ or $y = \sqrt{1 - x^2}$. But how do we find the derivative y for an equation where we are not able to solve for y explicitly? For example, if we have the equation

$$x^3 + y^3 - 9xy = 0 \text{ (Figure 15.10)}$$

we cannot solve for y in terms of x . However, there may exist one or more functions f such that if $y = f(x)$ then the equation

$$x^3 + [f(x)]^3 - 9x[f(x)] = 0$$

holds for all values of x in the domain of f . Hence, the function f is defined implicitly by the given equation.

With the assumption that the equation $x^3 + y^3 - 9xy = 0$ defines y as at least one differentiable function of x (see Figure 15.11), the derivative of y with respect to x , $\frac{dy}{dx}$, can be found by the technique of **implicit differentiation**.

Figure 15.10 The graph of $x^3 + y^3 - 9xy = 0$ (called a *folium*, Latin for 'leaf'). This type of curve was first studied by Rene Descartes in 1638.

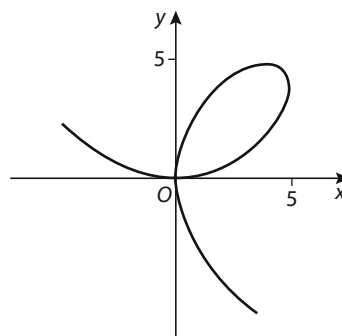
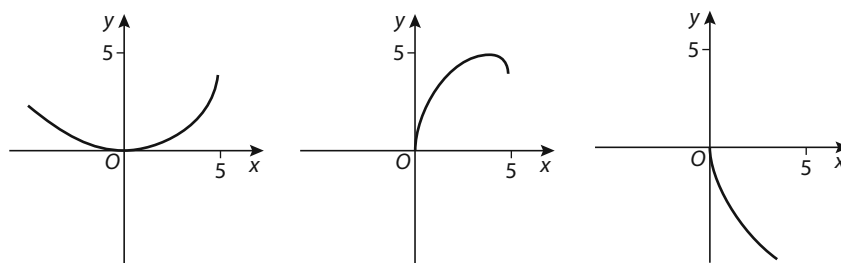

Figure 15.11 Although the equation $x^3 + y^3 - 9xy = 0$ is not a function, we can see that the graph of the equation can be separated into the graphs of three separate functions (they each pass the vertical line test for a function). This demonstrates that the equation implicitly defines y as three functions of x .



Initially we differentiate term-by-term, with respect to x , obtaining

$$\frac{d}{dx}(x^3) + \frac{d}{dx}(y^3) - \frac{d}{dx}(9xy) = \frac{d}{dx}(0).$$

The first and last terms are easily differentiated, and we can apply the constant rule to the third term, giving

$$3x^2 + \frac{d}{dx}(y^3) - 9\frac{d}{dx}(xy) = 0.$$

Differentiating the second and third terms is a little more complicated requiring the use of the chain rule (and also product rule for the third

term). If y is defined implicitly as a function of x , then y^3 is also a (composite) function of x . Thus, applying the appropriate rules, we have

$$3x^2 + 3y^2 \cdot \frac{d}{dx}(y) - 9\left(x \cdot \frac{d}{dx}(y) + y \cdot \frac{d}{dx}(x)\right) = 0$$

$$3x^2 + 3y^2 \cdot \frac{dy}{dx} - 9\left(x \cdot \frac{dy}{dx} + y\right) = 0$$

$$3x^2 + 3y^2 \frac{dy}{dx} - 9x \frac{dy}{dx} - 9y = 0$$

Now we solve the equation for $\frac{dy}{dx}$.

$$\frac{dy}{dx}(3y^2 - 9x) = -3x^2 + 9y \Rightarrow \frac{dy}{dx} = \frac{-3x^2 + 9y}{3y^2 - 9x}$$

Therefore, $\frac{dy}{dx} = \frac{-x^2 + 3y}{y^2 - 3x}$.

The process of implicit differentiation has given us a formula for $\frac{dy}{dx}$ that is the slope of the curve at any point (except where there is a vertical tangent and slope is undefined) and it is in terms of *both* x and y . This is not unexpected since we can see from the graph of the equation (Figure 15.10) that it is possible for two or three different points on the curve to have the same x -coordinate and the slope of the curve (given by $\frac{dy}{dx}$) will depend on the values of both x and y , and not only x as with functions where y is explicitly defined in terms of x .

In the examples and exercises of this section it is assumed that for any given equation y is implicitly defined as a differentiable function of x (or more than one differentiable function as in the above example) so that the technique of implicit differentiation can be applied.

Process of implicit differentiation

- 1 Differentiate, term-by-term, both sides of the equation **with respect to x** . The chain rule must be applied for any terms containing y .
- 2 Collect all terms containing $\frac{dy}{dx}$ on one side of the equation and all other terms on the other side.
- 3 Factor out $\frac{dy}{dx}$.
- 4 Solve for $\frac{dy}{dx}$ by dividing both sides by the factor multiplying $\frac{dy}{dx}$.
- 5 Simplify the result, if possible.

Example 14

Consider the equation for the unit circle $x^2 + y^2 = 1$ which is a relation (not a function).

a) Solve for y , and write all equations that express y as a function of x .

Find $\frac{dy}{dx}$ for each of these functions.

b) Find $\frac{dy}{dx}$ by implicit differentiation.

c) Find the equation of the line tangent to the unit circle at the point $\left(-\frac{1}{2}, \frac{\sqrt{3}}{2}\right)$.

Solution

a) Solving for y produces two equations, each defining y as a function of x .

$$x^2 + y^2 = 1 \Rightarrow y^2 = 1 - x^2 \Rightarrow y = \sqrt{1 - x^2} \text{ and } y = -\sqrt{1 - x^2}$$

Differentiating each of these with respect to x gives,

$$\frac{dy}{dx} = \frac{d}{dx}(\sqrt{1 - x^2}) = \frac{d}{dx}[(1 - x^2)^{\frac{1}{2}}] = \frac{1}{2}(1 - x^2)^{-\frac{1}{2}}(-2x) \Rightarrow$$

$$\frac{dy}{dx} = \frac{-x}{\sqrt{1 - x^2}}$$

$$\frac{dy}{dx} = \frac{d}{dx}(-\sqrt{1 - x^2}) = \frac{d}{dx}[-(1 - x^2)^{\frac{1}{2}}]$$

$$= -\frac{1}{2}(1 - x^2)^{-\frac{1}{2}}(-2x) \Rightarrow \frac{dy}{dx} = \frac{x}{\sqrt{1 - x^2}}$$

For the function $y = \sqrt{1 - x^2}$ we have $\frac{dy}{dx} = \frac{-x}{\sqrt{1 - x^2}}$.

$$\text{Since } y = \sqrt{1 - x^2}, \text{ then } \frac{dy}{dx} = -\frac{x}{y}.$$

For the function $y = -\sqrt{1 - x^2}$ we have $\frac{dy}{dx} = \frac{x}{\sqrt{1 - x^2}}$.

$$\text{Since } y = -\sqrt{1 - x^2}, \Rightarrow -y = \sqrt{1 - x^2}, \text{ then } \frac{dy}{dx} = -\frac{x}{y}.$$

b) $\frac{d}{dx}(x^2) + \frac{d}{dx}(y^2) = \frac{d}{dx}(1)$ Differentiating both sides term-by-term.

$$2x + 2y \frac{dy}{dx} = 0 \quad \text{Chain rule applied to differentiate } y^2.$$

$$2y \frac{dy}{dx} = -2x$$

$$\frac{dy}{dx} = \frac{-2x}{2y} \quad \text{Solving for } \frac{dy}{dx}$$

$$\text{Therefore, } \frac{dy}{dx} = -\frac{x}{y}.$$

c) At the point $(-\frac{1}{2}, \frac{\sqrt{3}}{2})$ the slope of the tangent line is $\frac{dy}{dx} = -\left(\frac{-\frac{1}{2}}{\frac{\sqrt{3}}{2}}\right)$
 $= \frac{1}{\sqrt{3}} = \frac{\sqrt{3}}{3}$.

Substituting into the point-slope form gives,

$$y - \frac{\sqrt{3}}{2} = \frac{\sqrt{3}}{3}\left(x + \frac{1}{2}\right) \Rightarrow y = \frac{\sqrt{3}}{3}x + \frac{\sqrt{3}}{6} + \frac{\sqrt{3}}{2} \Rightarrow y = \frac{\sqrt{3}}{3}x + \frac{2\sqrt{3}}{3}$$

We can get a visual check by graphing the unit circle and the tangent line on our GDC. In order to graph the complete unit circle on our GDC we need to graph both functions found in part a).

```
Plot1 Plot2 Plot3
\Y1=√(1-X^2)
\Y2=-√(1-X^2)
\Y3=(√(3)/3)X+2√(3)/3
\Y4=
\Y5=
\Y6=
```

```
WINDOW
Xmin=-3
Xmax=3
Xscl=1
Ymin=-2
Ymax=2
Yscl=1
Xres=1
```

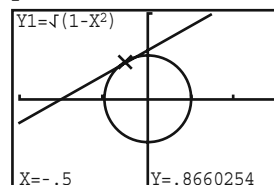

● **Hint:** Example 14 illustrates that even when it is possible to solve an equation explicitly for y in terms of x , it may be more efficient to find $\frac{dy}{dx}$ by implicit differentiation.

Example 15

- a) Find the points on the graph of $x^2 + 4xy + 13y^2 = 9$ at which the tangent is horizontal.
- b) Determine whether each point is a maximum, minimum or neither.

Solution

- a) We need to find $\frac{dy}{dx}$ which we do by implicit differentiation.

$$\frac{d}{dx}(x^2) + 4 \frac{d}{dx}(xy) + 13 \frac{d}{dx}(y^2) = \frac{d}{dx}(9) \quad \text{Differentiating both sides term-by-term.}$$

$$2x + 4\left(x \frac{d}{dx}(y) + y \frac{d}{dx}(x)\right) + 13\left(2y \frac{d}{dx}(y)\right) = 0 \quad \text{Applying chain and product rules.}$$

$$2x + 4x \frac{dy}{dx} + 4y + 26y \frac{dy}{dx} = 0 \quad \text{Collecting terms containing } \frac{dy}{dx} \text{ on one side.}$$

$$\frac{dy}{dx}(4x + 26y) = -2x - 4y \quad \text{Factor out } \frac{dy}{dx}.$$

$$\frac{dy}{dx} = \frac{-2x - 4y}{4x + 26y} = \frac{-x - 2y}{2x + 13y} \quad \text{Solving for } \frac{dy}{dx}.$$

To find horizontal tangents, solve $\frac{dy}{dx} = 0$.

$$\frac{-x - 2y}{2x + 13y} = 0 \Rightarrow -x - 2y = 0 \Rightarrow y = -\frac{x}{2}$$

Of course, there are an infinite number of ordered pairs (x, y) that satisfy the equation $y = -\frac{x}{2}$. But the only ordered pairs that we want are ones that are on the curve $x^2 + 4xy + 13y^2 = 9$. So we substitute $-\frac{x}{2}$ for y and solve to find x -coordinates of points on the curve

where $\frac{dy}{dx} = 0$.

$$x^2 + 4xy + 13y^2 = 9 \Rightarrow x^2 + 4x\left(-\frac{x}{2}\right) + 13\left(-\frac{x}{2}\right)^2 = 9$$

$$x^2 - 2x^2 + \frac{13}{4}x^2 = 9$$

$$4x^2 - 8x^2 + 13x^2 = 36 \quad \text{Multiplying both sides by 4.}$$

$$9x^2 = 36$$

$$x^2 = 4 \Rightarrow x = 2 \text{ or } x = -2$$

$$y\text{-coordinates: for } x = 2, y = -\frac{2}{2} = -1; \text{ for } x = -2, y = -\left(\frac{-2}{2}\right) = 1$$

Therefore, the tangents to the curve at $(2, -1)$ and $(-2, 1)$ are horizontal.

- b) It is very difficult to determine the nature of the points $(2, -1)$ and $(-2, 1)$ by testing the sign of the derivative to either side of each point. Since $\frac{dy}{dx}$ is in terms of both x and y we need an explicit equation for y in terms of x to find the y -coordinate – but no explicit equation for y exists.

It is also impossible to graph the curve $x^2 + 4xy + 13y^2 = 9$ on our GDC to see its shape. Let's find the second derivative, $\frac{d^2y}{dx^2}$, and apply the second derivative test (Section 13.3).

$$\begin{aligned} \frac{d^2y}{dx^2} &= \frac{d}{dx} \left(\frac{-x - 2y}{2x + 13y} \right) \\ &= \frac{(2x + 13y) \left[\frac{d}{dx}(-x - 2y) \right] - (-x - 2y) \left[\frac{d}{dx}(2x + 13y) \right]}{(2x + 13y)^2} && \text{Applying quotient rule.} \\ &= \frac{(2x + 13y) \left(-1 - 2 \frac{dy}{dx} \right) + (x + 2y) \left(2 + 13 \frac{dy}{dx} \right)}{(2x + 13y)^2} \\ &= (2x + 13y) \left(-1 - 2 \left(\frac{-x - 2y}{2x + 13y} \right) \right) + (x + 2y) \left(2 + 13 \left(\frac{-x - 2y}{2x + 13y} \right) \right) && \text{Substituting for } \frac{dy}{dx}. \\ &= \frac{2x + 13y}{2x + 13y} \cdot \frac{(2x + 13y) \left(-1 + \frac{2x + 4y}{2x + 13y} \right) + (x + 2y) \left(2 - \frac{13x + 26y}{2x + 13y} \right)}{(2x + 13y)^2} \\ &= \frac{(2x + 13y)(-2x - 13y + 2x + 4y) + (x + 2y)(4x + 26y - 13x - 26y)}{(2x + 13y)^3} \\ &= \frac{(2x + 13y)(-9y) + (x + 2y)(-9x)}{(2x + 13y)^3} \\ \therefore \frac{d^2y}{dx^2} &= -\frac{9x^2 + 36xy + 117y^2}{(2x + 13y)^3} = -\frac{9(x^2 + 4xy + 13y^2)}{(2x + 13y)^3} \end{aligned}$$

Now applying the second derivative test for both points where $\frac{dy}{dx} = 0$, we have

$$\begin{aligned} \text{for } (2, -1), \frac{d^2y}{dx^2} &= \frac{-9(2^2 + 4(2)(-1) + 13(-1)^2)}{(2(2) + 13(-1))^3} \\ &= \frac{81}{125} > 0 \Rightarrow (2, -1) \text{ is a minimum} \end{aligned}$$

$$\begin{aligned} \text{for } (-2, 1), \frac{d^2y}{dx^2} &= \frac{-9(-2)^2 + 4(-2)(1) + 13(1)^2}{(2(-2) + 13(1))^3} \\ &= -\frac{3}{343} < 0 \Rightarrow (-2, 1) \text{ is a maximum} \end{aligned}$$

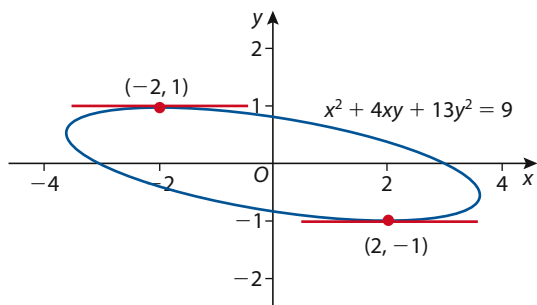

Even though it is not possible to graph the curve $x^2 + 4xy + 13y^2 = 9$ on our GDC, it is possible to find graphing software that can. The graph visually confirms our results for parts a) and b) of Example 15.

Previously we have established the rules for differentiating trigonometric functions and exponential functions. We still need to determine how to differentiate other important non-algebraic functions, namely logarithmic functions and inverse trigonometric functions.

Derivatives of logarithmic functions

At the start of the previous section we explored how we can often form a strong conjecture for the derivative of a function by analyzing the shape of the function's graph with the aid of some features of our GDC. Let's take this informal approach for finding the derivative for the natural logarithm function, $y = \ln x$, and then check our conjecture by deriving $\frac{d}{dx}(\ln x)$ by means of implicit differentiation.

The graph of $y = \ln x$ (Figure 15.12) is a particularly straightforward one. Its x -intercept is $(1, 0)$, and since its domain is all positive real numbers, it has no y -intercept. It is asymptotic to the y -axis, and the graph rises steadily, though less steeply as $x \rightarrow \infty$. There is neither an upper nor a lower bound, so its range is all real numbers.

Let's cleverly use our GDC to view a graph of $y = \ln x$, a graph of its derivative, and to construct a table of ordered pairs with x and the value of the derivative at x (as computed by the GDC).

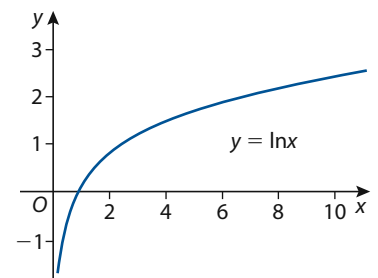
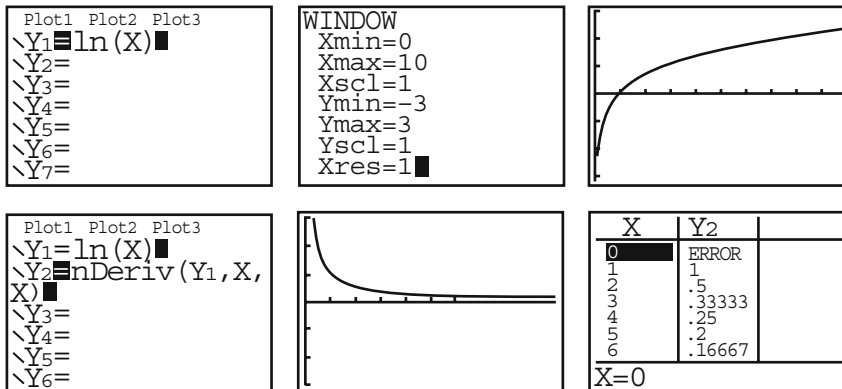

Figure 15.12



In the table, each value in the Y_2 column is the slope of the curve (derivative) at the particular x value for $y = \ln x$. From the graph of the derivative and especially from the table, we conjecture that the derivative of $\ln x$ is $\frac{1}{x}$. This agrees with the fact that for $x > 0$, the slope of the graph of $y = \ln x$ is always positive and as x increases the slope decreases.

The inverse of $y = \ln x$ is $y = e^x$. Knowing this and that $\frac{d}{dx}(e^x) = e^x$, we can use implicit differentiation to confirm our conjecture.

$$y = \ln x$$

$$e^y = x \quad \text{Inverse function relationship.}$$

$$\frac{d}{dx}(e^y) = \frac{d}{dx}(x) \quad \text{Differentiate implicitly.}$$

$$e^y \frac{dy}{dx} = 1$$

$$\frac{dy}{dx} = \frac{1}{e^y}$$

$$\frac{dy}{dx} = \frac{1}{x} \quad \text{Substituting } x \text{ for } e^y.$$

Therefore, $\frac{d}{dx}(\ln x) = \frac{1}{x}$.

The derivative of the natural logarithm function

If $f(x) = \ln x$, then $f'(x) = \frac{1}{x}$. Or, in Leibniz notation, $\frac{d}{dx}(\ln x) = \frac{1}{x}$.



It is interesting to note that the derivative of the **non-algebraic** function $f(x) = \ln x$ is the **algebraic** function $f'(x) = \frac{1}{x}$. Non-algebraic functions, such as trigonometric, exponential and logarithmic functions are often referred to as 'transcendental' functions. A **transcendental function** is a function that is not algebraic – in other words, it cannot be composed of a finite number of the elementary operations of addition, subtraction, multiplication, division and extracting a root. A **transcendental number** is a real number that is not a root of any polynomial equation with rational coefficients. For example, π and e are transcendental numbers.

What about the derivative of a logarithmic function with a base, b , other than e ; that is, logarithmic functions other than the natural logarithmic function?

To find the derivative of $\log_b x$ with any base ($b > 0$, $b \neq 1$), we can use the change of base formula (Section 5.4) for logarithms to express $\log_b x$ in terms of the natural logarithm, $\ln x$, and then differentiate.

$$\log_b x = \frac{\ln x}{\ln b} \quad \text{Applying change of base formula.}$$

$$\frac{d}{dx}(\log_b x) = \frac{d}{dx}\left(\frac{\ln x}{\ln b}\right) = \frac{d}{dx}\left(\frac{1}{\ln b} \cdot \ln x\right) \quad \text{Differentiating both sides.}$$

$$= \frac{1}{\ln b} \cdot \frac{d}{dx}(\ln x) \quad \frac{1}{\ln b} \text{ is a constant.}$$

$$= \frac{1}{\ln b} \cdot \frac{1}{x}$$

$$\text{Therefore, } \frac{d}{dx}(\log_b x) = \frac{1}{x \ln b}.$$

The derivative of the general logarithm function

If $f(x) = \log_b x$ ($b > 0$, $b \neq 1$), then $f'(x) = \frac{1}{x \ln b}$. Or, in Leibniz notation, $\frac{d}{dx}(\log_b x) = \frac{1}{x \ln b}$.

Example 16

a) Given $g(x) = \frac{1+x}{1-x}$, find $g'(x)$.

b) Hence, find $f'(x)$ for $f(x) = \ln\left(\frac{1+x}{1-x}\right)$.

c) (i) Show that $f(x)$ is an odd function.

(ii) Show that $f(x)$ has no stationary points.

(iii) Show that $f(x)$ has one point of inflexion, and give its coordinates.

Solution

$$\text{a) } g'(x) = \frac{(1-x)\frac{d}{dx}(1+x) - (1+x)\frac{d}{dx}(1-x)}{(1-x)^2} \quad \text{Applying quotient rule.}$$

$$= \frac{1-x+1+x}{(1-x)^2}$$

$$\therefore g'(x) = \frac{2}{(1-x)^2}$$

$$\text{b) } f'(x) = \frac{d}{dx} \left[\ln \left(\frac{1+x}{1-x} \right) \right] = \frac{1}{\frac{1+x}{1-x}} \cdot \frac{d}{dx} \left(\frac{1+x}{1-x} \right) \quad \text{Applying } \frac{d}{dx}(\ln x) = \frac{1}{x} \text{ and chain rule.}$$

$$= \left(\frac{1-x}{1+x} \right) \left(\frac{2}{(1-x)^2} \right) \quad \text{Substituting result from part a).}$$

$$= \frac{1}{1+x} \cdot \frac{2}{1-x}$$

$$\therefore f'(x) = \frac{2}{1-x^2}$$

- c) (i) In Section 7.3 we stated that a function f is odd if, for each x in the domain of f , $f(-x) = -f(x)$ with its graph symmetric about the origin. This symmetry leads to the fact (see question 25 in Exercise 13.2) that the graph of the derivative of an odd function is symmetric about the y -axis, i.e. an even function. A function f is even if $f(-x) = f(x)$. Thus, it will suffice to show that $f'(x)$ is even in order to show that $f(x)$ is odd.

$$f'(-x) = \frac{2}{1-(-x)^2} = \frac{2}{1-x^2} = f'(x)$$

Therefore, $f'(x)$ is even and it follows that $f(x)$ is odd.

- (ii) A stationary point for a function can only occur where its derivative is zero.

Clearly, $f'(x) = \frac{2}{1-x^2} \neq 0$ because a rational expression can

only equal zero when its numerator is zero. Therefore, $f(x)$ has no stationary points.

- (iii) To find any inflexion points we start by finding where the second derivative is zero.

$$f''(x) = \frac{d}{dx} \left(\frac{2}{1-x^2} \right) = 2 \frac{d}{dx} [(1-x^2)^{-1}] \quad \text{Power and chain rules instead of quotient rule.}$$

$$= 2[-(1-x^2)^{-2}(-2x)]$$

$$= f''(x) = \frac{4x}{(1-x^2)^2} = 0 \text{ when } x = 0$$

To confirm that an inflexion point does occur at $x = 0$ we need to show that the concavity of the graph of f changes at $x = 0$ ($f''(x)$ changes sign). Because $f(x)$ is defined only for $-1 < x < 1$, we choose $x = -\frac{1}{2}$ and $x = \frac{1}{2}$ as test points.

$$f''\left(-\frac{1}{2}\right) = \frac{4\left(-\frac{1}{2}\right)}{\left(1 - \left(-\frac{1}{2}\right)^2\right)^2} = -\frac{32}{9} < 0 \text{ and}$$

$$f''\left(\frac{1}{2}\right) = \frac{4\left(\frac{1}{2}\right)}{\left(1 - \left(\frac{1}{2}\right)^2\right)^2} = \frac{32}{9} > 0$$

Since $f''(x)$ changes sign (and $f(x)$ changes concavity) at $x = 0$, f has an inflexion point there. $f(0) = \ln\left(\frac{1+0}{1-0}\right) = \ln(1) = 0$. Therefore, the inflexion point is at $(0, 0)$. (See GDC images below).

```
Plot1 Plot2 Plot3
\Y1=ln((1+X)/(1-
X))
\Y2=
\Y3=
\Y4=
\Y5=
\Y6=
```

```
WINDOW
Xmin=-1.25
Xmax=1.25
Xscl=1
Ymin=-6
Ymax=6
Yscl=1
Xres=1
```

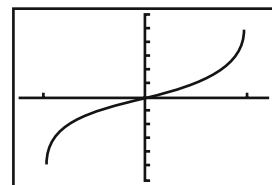

Example 17

Find the equation of the line tangent to the graph of $y = \log_{10}(x^3)$ at the point $x = 4$. Express the equation exactly with any logarithms being expressed as natural logarithms.

Solution

$$\begin{aligned} \frac{dy}{dx} &= \frac{d}{dx}[\log_{10}(x^3)] = \frac{1}{x^3 \ln 10} \cdot \frac{d}{dx}(x^3) \text{ Applying } \frac{d}{dx}(\log_b x) = \frac{1}{x \ln b} \text{ and chain rule.} \\ &= \frac{1}{x^3 \ln 10} \cdot 3x^2 \\ \frac{dy}{dx} &= \frac{3}{x \ln 10} \end{aligned}$$

[Alternatively, we could have used laws of logarithms to write

$y = \log_{10}(x^3) = 3 \log_{10} x$ and then $\frac{dy}{dx} = 3 \frac{d}{dx}(\log_{10} x) = \frac{3}{x \ln 10}$, avoiding use of the chain rule.]

When $x = 4$, $\frac{dy}{dx} = \frac{3}{4 \ln 10}$ and $y = \log_{10}(4^3) = \log_{10} 64 = \frac{\ln 64}{\ln 10}$ (using change of base formula). Thus, the tangent line intersects the curve at the point $\left(4, \frac{\ln 64}{\ln 10}\right)$ and has a slope of $\frac{3}{4 \ln 10}$. Substituting into the point-slope form for a linear equation gives:

$$\begin{aligned} y - \frac{\ln 64}{\ln 10} &= \frac{3}{4 \ln 10}(x - 4) \Rightarrow y = \frac{3x}{4 \ln 10} - \frac{3}{\ln 10} + \frac{\ln 64}{\ln 10} \Rightarrow \\ y &= \frac{3x}{4 \ln 10} + \frac{-3 + \ln 64}{\ln 10} \end{aligned}$$

Graphing the curve $y = \log_{10}(x^3)$ and the computed tangent line appears to give a good visual confirmation that the equation of the tangent line is correct.

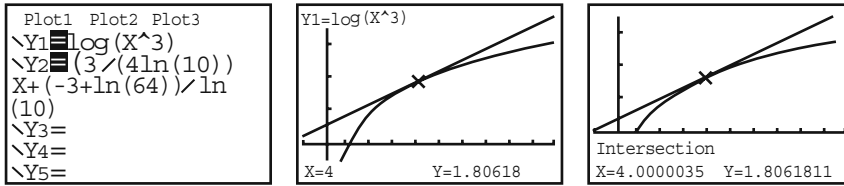

Derivatives of inverse trigonometric functions

In the preceding pages, we established that the derivative of the *non-algebraic* (transcendental) function $f(x) = \ln x$ is the *algebraic* function $f'(x) = \frac{1}{x}$. The same is true for the inverse trigonometric functions – they are transcendental but their derivatives are algebraic. The inverse trigonometric functions were discussed in Section 7.6. We will now use implicit differentiation to find the derivatives of the inverse functions for sine, cosine, and tangent functions – which are usually referred to as $\arcsin x$, $\arccos x$ and $\arctan x$ respectively. Their graphs are shown again in Figure 15.13.

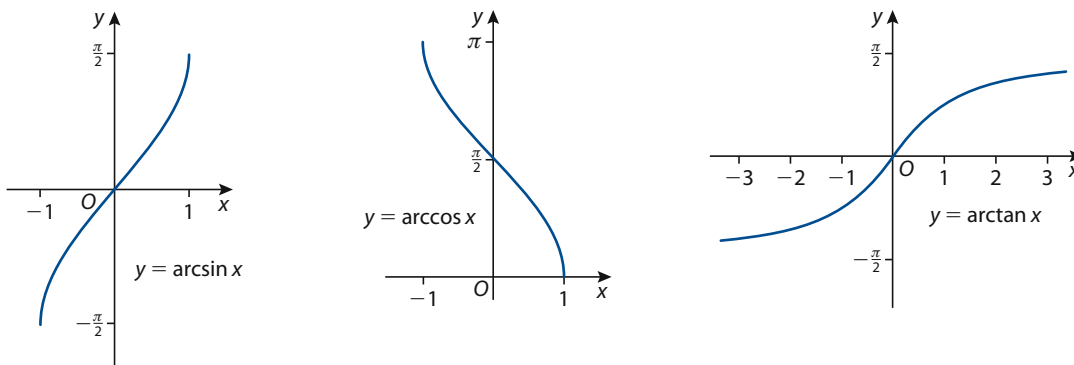

Figure 15.13

Given the smooth shape of their graphs we will assume that the functions $y = \arcsin x$, $y = \arccos x$ and $y = \arctan x$ are differentiable (i.e. the derivative exists) except where a vertical tangent exists. Since $y = \arcsin x$ and $y = \arccos x$ have vertical tangents at $x = -1$ and $x = 1$ they are differentiable throughout the interval $-1 < x < 1$. $y = \arctan x$ is differentiable for all real numbers.

Recall the definition of the arcsine function,

$$y = \arcsin x \Rightarrow \sin y = x \text{ for } -\frac{\pi}{2} \leq y \leq \frac{\pi}{2}.$$

Differentiating $\sin y = x$ implicitly with respect to x gives:

$$\frac{d}{dx}(\sin y) = \frac{d}{dx}(x) \quad \text{Differentiating both sides.}$$

$$(\cos y) \frac{dy}{dx} = 1 \quad \text{Implicit differentiation.}$$

$$\frac{dy}{dx} = \frac{1}{\cos y} \quad \text{Dividing by } \cos y.$$

That is, $\frac{d}{dx}(\arcsin x) = \frac{1}{\cos y}$.

• **Hint:** Recall from Chapter 7 that the notations $y = \arcsin x$ and $y = \sin^{-1} x$ are synonymous, but we will generally use $y = \arcsin x$.

Dividing by $\cos y$ in the last step is allowed because $\cos y \neq 0$ for the interval in which $y = \arcsin x$ is differentiable, i.e. $-\frac{\pi}{2} < y < \frac{\pi}{2}$ (quadrants I and IV). In fact, $\cos y > 0$ for $-\frac{\pi}{2} < y < \frac{\pi}{2}$. From the identity $\sin^2 x + \cos^2 x = 1$ we have $\cos x = \pm\sqrt{1 - \sin^2 x}$. Since $\cos y > 0$ we can replace $\cos y$ with $\sqrt{1 - \sin^2 y}$ and because $\sin y = x$ we get $\cos y = \sqrt{1 - x^2}$. Therefore, $\frac{d}{dx}(\arcsin x) = \frac{1}{\sqrt{1 - x^2}}$.

We can apply a similar process to find the derivative of the arcos x function, obtaining the result

$$\frac{d}{dx}(\arccos x) = -\frac{1}{\sqrt{1 - x^2}}.$$

Although the domain for the inverse sine and inverse cosine functions is the fairly narrow closed interval $-1 \leq x \leq 1$ and they are differentiable on the open interval $-1 < x < 1$, the inverse tangent function is defined and differentiable for all real numbers. To find $\frac{d}{dx}(\arctan x)$, we follow a similar procedure to that for $\frac{d}{dx}(\arcsin x)$.

The definition of the inverse tangent (arctan) function is

$$y = \arctan x \Rightarrow \tan y = x \text{ for } -\frac{\pi}{2} \leq y \leq \frac{\pi}{2}.$$

Differentiating $\tan y = x$ implicitly with respect to x gives:

$$\frac{d}{dx}(\tan y) = \frac{d}{dx}(x) \quad \text{Differentiating both sides.}$$

$$(\sec^2 y) \frac{dy}{dx} = 1 \quad \text{Implicit differentiation.}$$

$$\frac{dy}{dx} = \frac{1}{\sec^2 y} \quad \text{Dividing by } \sec^2 y.$$

$$\frac{dy}{dx} = \frac{1}{1 + \tan^2 y} \quad \text{Applying identity } 1 + \tan^2 y = \sec^2 y.$$

$$\text{Therefore, } \frac{d}{dx}(\arctan x) = \frac{1}{1 + x^2}. \quad \tan y = x.$$

The derivatives for the inverse secant, inverse cosecant and inverse cotangent functions can also be found by means of implicit differentiation. They are included in the list below but are not necessary for this course.

Derivatives of the inverse trigonometric functions

$$\frac{d}{dx}(\arcsin x) = \frac{1}{\sqrt{1 - x^2}} \quad \frac{d}{dx}(\operatorname{arccsc} x) = -\frac{1}{x\sqrt{x^2 - 1}}$$

$$\frac{d}{dx}(\arccos x) = -\frac{1}{\sqrt{1 - x^2}} \quad \frac{d}{dx}(\operatorname{arcsec} x) = \frac{1}{x\sqrt{x^2 - 1}}$$

$$\frac{d}{dx}(\arctan x) = \frac{1}{1 + x^2} \quad \frac{d}{dx}(\operatorname{arccot} x) = -\frac{1}{1 + x^2}$$

Example 18

Find the $\frac{dy}{dx}$ for each of the following.

a) $y = \cos^{-1}(e^{2x})$

b) $y = x \arcsin 2x + \frac{1}{2}\sqrt{1 - 4x^2}$

c) $\ln(x + y) = \arctan\left(\frac{x}{y}\right)$

Solution

$$a) \frac{dy}{dx} = \frac{d}{dx}[\cos^{-1}(e^{2x})] = \frac{-1}{\sqrt{1-(e^{2x})^2}} \cdot \frac{d}{dx}(e^{2x})$$

Chain rule and

$$\frac{d}{dx}(\arccos x) = \frac{-1}{\sqrt{1-x^2}}$$

$$= \frac{-1}{\sqrt{1-e^{4x}}} \cdot e^{2x} \cdot 2$$

Chain rule, again.

$$\frac{dy}{dx} = -\frac{2e^{2x}}{\sqrt{1-e^{4x}}}$$

$$b) \frac{dy}{dx} = \frac{d}{dx} \left(x \arcsin 2x + \frac{1}{2}(1-4x^2)^{\frac{1}{2}} \right)$$

$$= x \frac{d}{dx}(\arcsin 2x) + \arcsin 2x \frac{d}{dx}(x) + \frac{1}{2} \cdot \frac{1}{2}(1-4x^2)^{-\frac{1}{2}} \frac{d}{dx}(1-4x^2)$$

$$= x \left(\frac{1}{\sqrt{1-(2x)^2}} \frac{d}{dx}(2x) \right) + \arcsin 2x + \frac{-8x}{4\sqrt{1-4x^2}}$$

$$= \frac{2x}{\sqrt{1-4x^2}} + \arcsin 2x + \frac{-2x}{\sqrt{1-4x^2}}$$

$$\frac{dy}{dx} = \arcsin 2x$$

$$c) \frac{d}{dx}[\ln(x+y)] = \frac{d}{dx} \left[\arctan \left(\frac{x}{y} \right) \right]$$

Differentiating both sides implicitly.

$$\frac{1}{x+y} \left(1 + \frac{dy}{dx} \right) = \frac{1}{1 + \frac{x^2}{y^2}} \left(\frac{y - x \frac{dy}{dx}}{y^2} \right)$$

Chain rule,

$$\frac{d}{dx}(\arctan x) = \frac{1}{1+x^2},$$

quotient rule.

$$\frac{1 + \frac{dy}{dx}}{x+y} = \frac{y - x \frac{dy}{dx}}{x^2 + y^2}$$

$$x^2 + y^2 + \frac{dy}{dx}x^2 + \frac{dy}{dx}y^2 = xy + y^2 - \frac{dy}{dx}x^2 - \frac{dy}{dx}xy$$

$$\frac{dy}{dx}(2x^2 + xy + y^2) = xy - x^2$$

$$\frac{dy}{dx} = \frac{xy - x^2}{2x^2 + xy + y^2}$$

Example 19

A painting that is 175 cm from top to bottom is hanging on the wall of a gallery such that its base is 225 cm above the eye level of an observer. How far from the wall should the observer stand to get the best view of the painting, that is, so that the angle subtended at the observer's eye by the painting is a maximum? (This is similar to Example 34 in Section 7.6.)

Solution

Change all lengths from centimetres to metres.

$$\tan \theta = \frac{4}{x} \text{ and } \tan \beta = \frac{9}{x}$$

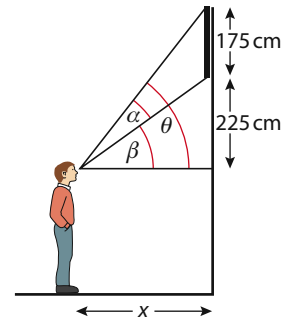

Because $0 < \theta < \frac{\pi}{2}$ and $0 < \beta < \frac{\pi}{2}$, we have

$$\theta = \arctan \frac{4}{x} \text{ and } \beta = \arctan \frac{9}{4x}$$

Substituting these values of θ and β into the equation $\alpha = \theta - \beta$ gives

$$\alpha = \arctan \frac{4}{x} - \arctan \frac{9}{4x}$$

Differentiating with respect to x gives:

$$\begin{aligned} \frac{d\alpha}{dx} &= \frac{d}{dx} \left[\arctan(4x^{-1}) - \arctan\left(\frac{9}{4}x^{-1}\right) \right] \\ &= \frac{1}{1 + (4x^{-1})^2}(-4x^{-2}) - \frac{1}{1 + \left(\frac{9}{4}x^{-1}\right)^2} \left(-\frac{9}{4}x^{-2}\right) \\ &= \frac{-4}{x^2 + 16} + \frac{\frac{9}{4}}{x^2 + \frac{81}{16}} \\ &= \frac{-4}{x^2 + 16} + \frac{36}{16x^2 + 81} \end{aligned}$$

Setting $\frac{d\alpha}{dx} = 0$, we get:

$$36(x^2 + 16) - 4(16x^2 + 81) = 0$$

$$-28x^2 + 252 = 0$$

$$x^2 = \frac{252}{28} = 9 \Rightarrow x = \pm 3, \text{ however } x \neq -3$$

We use the first derivative test to determine if the angle α is a maximum when $x = 3$, using test values of $x = 2$ and $x = 4$.

When $x = 2$, $\frac{d\alpha}{dx} = \frac{7}{145} > 0$ and when $x = 4$, $\frac{d\alpha}{dx} = -\frac{49}{2696} < 0$.

Hence, the angle α has an absolute maximum value at $x = 3$. Therefore, the observer should stand 3 metres away from the wall to get the 'best' view of the painting.

Summary of differentiation rules

Derivative of $f(x)$	$y = f(x) \Rightarrow f'(x) = \lim_{h \rightarrow 0} \frac{f(x+h) - f(x)}{h}$
Derivative of x^n	$f(x) = x^n \Rightarrow f'(x) = nx^{n-1}$
Derivative of $\sin x$	$f(x) = \sin x \Rightarrow f'(x) = \cos x$
Derivative of $\cos x$	$f(x) = \cos x \Rightarrow f'(x) = -\sin x$
Derivative of $\tan x$	$f(x) = \tan x \Rightarrow f'(x) = \sec^2 x$
Derivative of $\sec x$	$f(x) = \sec x \Rightarrow f'(x) = \sec x \tan x$
Derivative of $\csc x$	$f(x) = \csc x \Rightarrow f'(x) = -\csc x \cot x$
Derivative of $\cot x$	$f(x) = \cot x \Rightarrow f'(x) = -\csc^2 x$

Note: derivative rules for trigonometric functions only apply if x is in radian measure.

Derivative of e^x	$f(x) = e^x \Rightarrow f'(x) = e^x$
Derivative of b^x	$f(x) = b^x \Rightarrow f'(x) = b^x \ln b$
Derivative of $\ln x$	$f(x) = \ln x \Rightarrow f'(x) = \frac{1}{x}$
Derivative of $\log_b x$	$f(x) = \log_b x \Rightarrow f'(x) = \frac{1}{x \ln b}$

Derivative of $\arcsin x$	$f(x) = \arcsin x \Rightarrow f'(x) = \frac{1}{\sqrt{1-x^2}}$
Derivative of $\arccos x$	$f(x) = \arccos x \Rightarrow f'(x) = -\frac{1}{\sqrt{1-x^2}}$
Derivative of $\arctan x$	$f(x) = \arctan x \Rightarrow f'(x) = \frac{1}{1+x^2}$
Derivative of $\operatorname{arcsec} x$	$f(x) = \operatorname{arcsec} x \Rightarrow f'(x) = \frac{1}{x\sqrt{x^2-1}}$
Derivative of $\operatorname{arccsc} x$	$f(x) = \operatorname{arccsc} x \Rightarrow f'(x) = -\frac{1}{x\sqrt{x^2-1}}$
Derivative of $\operatorname{arccot} x$	$f(x) = \operatorname{arccot} x \Rightarrow f'(x) = -\frac{1}{1+x^2}$
Chain rule for composite functions:	$\frac{dy}{dx} = \frac{d}{dx}[f(g(x))] = f'(g(x)) \cdot g'(x)$
Product rule:	$\frac{dy}{dx} = \frac{d}{dx}[f(x) \cdot g(x)] = f(x) \cdot g'(x) + g(x) \cdot f'(x)$
Quotient rule:	$\frac{dy}{dx} = \frac{d}{dx}\left[\frac{f(x)}{g(x)}\right] = \frac{g(x) \cdot f'(x) - f(x) \cdot g'(x)}{[g(x)]^2}$

Exercise 15.3

In questions 1–12, find the derivative of y with respect to x , $\frac{dy}{dx}$, by implicit differentiation.

- | | |
|--|---|
| 1 $x^2 + y^2 = 16$ | 2 $x^2y + xy^2 = 6$ |
| 3 $x = \tan y$ | 4 $x^2 - 3xy^2 + y^3x - y^2 = 2$ |
| 5 $\frac{x}{y} - \frac{y}{x} = 1$ | 6 $xy\sqrt{x+y} = 1$ |
| 7 $x + \sin y = xy$ | 8 $x^2y^3 = x^4 - y^4$ |
| 9 $xy + e^y = 0$ | 10 $(x+2)^2 + (y+3)^2 = 25$ |
| 11 $x = \tan y$ | 12 $y + \sqrt{xy} = 3x^3$ |

In questions 13–16, find the lines that are a) tangent and b) normal to the curve at the given point.

- | | |
|--|---|
| 13 $x^3 - xy - 3y^2 = 0$, $(2, -2)$ | 14 $16x^4 + y^4 = 32$, $(1, 2)$ |
| 15 $2xy + \pi \sin y = 2\pi$, $(1, \frac{\pi}{2})$ | 16 $\sqrt[3]{xy} = 14x + y$, $(2, -32)$ |
- 17** For the circle $x^2 + y^2 = r^2$ show that the tangent line at any point (x_1, y_1) on the circle is perpendicular to the line that passes through (x_1, y_1) and the centre of the circle.
- 18** Consider the equation $x^2 + xy + y^2 = 7$.
- Find the two points where the curve intersects the x -axis. Show that the tangents to the curve at these two points are parallel.
 - Find any points where the tangent to the curve is parallel to the x -axis.
 - Find any points where the tangent to the curve is parallel to the y -axis.
- 19** The line that is normal to the curve $x^2 + 2xy - 3y^2 = 0$ at $(1, 1)$ intersects the curve at what other point?

In questions 20 and 21, find $\frac{dy}{dx}$ and $\frac{d^2y}{dx^2}$ for the given equation.

- | | |
|------------------------------|--------------------------|
| 20 $4x^2 + 9y^2 = 36$ | 21 $xy = 2x - 3y$ |
|------------------------------|--------------------------|

- 22** Consider the equation $xy^3 = 1$. Find $\frac{dy}{dx}$ and $\frac{d^2y}{dx^2}$ by two different methods.
- Solve for y in terms of x and differentiate explicitly.
 - Differentiate implicitly.

- 23** The graph (shown right) of the equation $x^2 + y^2 = 2x^2 + 2y^2 - x^2$ is a type of curve called a *cardioid*. A cardioid is a heart-shaped curve generated by a fixed point on a circle as it rolls around another circle having the same radius. Find the equation of the line tangent to this particular cardioid at the point $(0, \frac{1}{2})$.

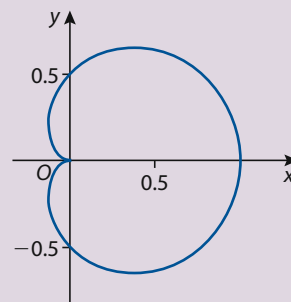

In questions 24–33, find the derivative of y with respect to x , $\frac{dy}{dx}$.

24 $y = \ln(x^3 + 1)$

25 $y = \ln(\sin x)$

26 $y = \log_5 \sqrt{x^2 - 1}$

27 $y = \ln \sqrt{\frac{1+x}{1-x}}$

28 $y = \sqrt{\log_{10} x}$

29 $y = \ln\left(\frac{a-x}{a+x}\right)$

30 $y = \ln(e^{\cos x})$

31 $y = \frac{1}{\log_3 x}$

32 $y = x \ln(x) - x$

33 $y = \ln(ax) - (\ln b) \log_b x$

- 34** Find the equation of the line tangent to the graph of $y = \log_2 x$ at the point $x = 8$. Express the equation exactly. Can you find a way to graph $y = \log_2 x$ on your GDC in order to check your answer?

- 35** Given $y = \sqrt{\frac{x^2 - 1}{x^2 + 1}}$ we could find $\frac{dy}{dx}$ by applying the chain rule and the quotient rule. However, it is much easier to first take the natural logarithm of both sides, use the properties of logarithms to simplify as much as possible, and then differentiate implicitly to find $\frac{dy}{dx}$. This technique is called *logarithmic differentiation*. Use this technique to show that $\frac{dy}{dx} = \frac{2x}{(x^2 - 1)^{\frac{1}{2}}(x^2 + 1)^{\frac{3}{2}}}$.

- 36** Find the x -coordinate, between 0 and 1, of the point of inflexion on the graph of the function $f(x) = x^2 \ln(x^2)$. Express your answer exactly.
- 37** a) Given $g(x) = \frac{\ln x}{x}$, find expressions for $g'(x)$ and $g''(x)$.
b) Show that g has an absolute maximum at $x = e$, and state the maximum value of g .

In questions 38–41, find the derivative of y with respect to x , $\frac{dy}{dx}$.

38 $y = \arctan(x + 1)$

39 $y = \sin^{-1}\left(\frac{x}{\sqrt{1+x^2}}\right)$

40 $y = \arccos\left(\frac{3}{x^2}\right)$

41 $\ln \sqrt{1+x^2} = x \tan^{-1} x$

- 42** Given that $f(x) = \arcsin x + \arccos x$, find $f'(x)$. What can you conclude about the function f ?

43 Show if a is a constant that

a) $\frac{d}{dx} \left[\arctan \left(\frac{x}{a} \right) \right] = \frac{a}{a^2 + x^2}$ b) $\frac{d}{dx} \left[\arcsin \left(\frac{x}{a} \right) \right] = \frac{1}{\sqrt{a^2 - x^2}}$

44 Find the equation of the line tangent to the curve $y = 4x \arctan 2x$ at the point on the curve where $x = \frac{1}{2}$. Express the equation exactly in the form $y = mx + c$, where m and c are constants.

45 Consider the function $f(x) = \arcsin(\cos x)$ with domain of $0 \leq x < \pi$.

a) Prove that f is a linear function.

b) Express the function exactly in the form $f(x) = ax + b$, where a and b are constants.

46 A 3-metre tall statue is on top of a column such that the bottom of the statue is 2 metres above the eye level of a person viewing the statue. How far from the base of the column should the person stand to get the best view of the statue, that is, so that the angle subtended at the observer's eye by the statue is a maximum?

47 A particle moves along the x -axis so that its displacement, s (in metres), from the origin at any time $t \geq 0$ (in seconds) is given by $s(t) = \arctan \sqrt{t}$.

a) Find the exact velocity of the particle at (i) $t = 1$ second, and at (ii) $t = 4$ seconds.

b) Find the exact acceleration of the particle at (i) $t = 1$ second, and at (ii) $t = 4$ seconds.

c) Describe the motion of the particle.

d) What is the limiting displacement of the particle as t approaches infinity?

15.4 Related rates

A claim was made in the first section of this chapter that 'the chain rule is the most important, and most widely used, rule of differentiation'. The chain rule has been repeatedly applied in all parts of this chapter thus far. Another important use of the chain rule is to find the rates of change of two or more variables that are changing with respect to time. Calculus provides us with the tools and techniques to solve problems where quantities (variables) are changing rather than static.

When a stone is thrown into a pond, a circular pattern of ripples is formed. In this situation we can observe an ever-widening circle moving across the water. As the circular ripple moves across the water, the radius r of the circle, its circumference C , and its area A all increase as a function of time t . Not only are these quantities (variables) functions of time, but their values at any particular time t are related to one another by familiar formulae such as $C = 2\pi r$ and $A = \pi r^2$. Thus their rates of change are also related to one another.

Example 20

A stone is thrown into a pond causing ripples in the form of concentric circles to move away from the point of impact at a rate of 20 cm per second. Find the following when a circular ripple has a radius of 50 cm and again when its radius is 100 cm.

a) the rate of change of the circle's circumference

b) the rate of change of the circle's area

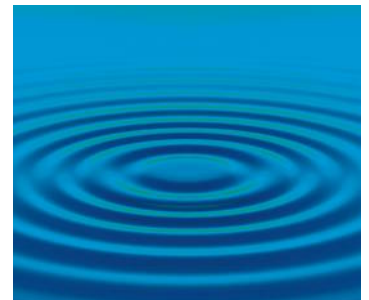

Solution

In calculus, a derivative represents a rate of change of one variable with respect to another variable. If the circles are moving outward at a rate of 20 cm/sec, then the rate of change of the radius is 20 cm/sec, and in the notation of calculus we write

$$\frac{dr}{dt} = 20.$$

- a) Knowing that the relationship between the radius, r , and the circumference, C , is $C = 2\pi r$, and that the rate of change of the radius with respect to time is $\frac{dr}{dt} = 20$, we can use the chain rule to find the rate of change of the circumference with respect to time, i.e. $\frac{dC}{dt}$.

$$\frac{dC}{dt} = \frac{dC}{dr} \cdot \frac{dr}{dt}$$

We need to find $\frac{dC}{dr}$, the rate of change (derivative) of the circumference with respect to the radius. This rate can be derived from the relationship between the variables.

$$C = 2\pi r$$

$$\frac{d}{dr}(C) = \frac{d}{dr}(2\pi r) \quad \text{Differentiate both sides with respect to } r.$$

$$\frac{dC}{dr} = 2\pi \quad \text{Implicit differentiation on the left side.}$$

Since the circumference C is a linear function of the radius r ($C = 2\pi r$), the derivative $\frac{dC}{dr}$ is a constant.

We now substitute in for $\frac{dC}{dr}$ and $\frac{dr}{dt}$ to find the rate of change of the circumference with respect to time, $\frac{dC}{dt}$.

$$\frac{dC}{dt} = \frac{dC}{dr} \cdot \frac{dr}{dt} \Rightarrow \frac{dC}{dt} = 2\pi \cdot 20 = 40\pi \text{ cm/sec}$$

The rate of change of a circular ripple's circumference is constant (40π). Therefore, the rate of change of the circumference is 40π cm/sec when the radius is 50 cm and also when its 100 cm.

- b) Similarly, to find the rate of change of the area with respect to time, $\frac{dA}{dt}$, we can use the chain rule to write

$$\frac{dA}{dt} = \frac{dA}{dr} \cdot \frac{dr}{dt}.$$

Find $\frac{dA}{dr}$ from the formula, $A = \pi r^2$, that relates the variables A and r .

$$\frac{d}{dr}(A) = \frac{d}{dr}(\pi r^2) \quad \text{Differentiate both sides with respect to } r.$$

$$\frac{dA}{dr} = \pi(2r) = 2\pi r \quad \text{Implicit differentiation on the left side.}$$

• **Hint:** There is a slightly different method to determine $\frac{dC}{dt}$. We can find the rate by differentiating implicitly with respect to time, t , both sides of the equation, $C = 2\pi r$, that gives the relationship between the two changing quantities (variables).

$$C = 2\pi r$$

Differentiate both sides with respect to t :

$$\frac{d}{dt}(C) = \frac{d}{dt}(2\pi r)$$

Implicit differentiation:

$$\frac{dC}{dt} = 2\pi \frac{dr}{dt}$$

Substitute $\frac{dr}{dt} = 20$:

$$\frac{dC}{dt} = 2\pi \cdot 20 = 40\pi \text{ cm/sec}$$

Since the area A is a non-linear function of the radius r ($A = \pi r^2$), the derivative $\frac{dA}{dr}$ is not a constant but has different values depending on the value of r .

We substitute in for $\frac{dA}{dr}$ and $\frac{dr}{dt}$ to find the rate of change of the area with respect to time, $\frac{dA}{dt}$.

$$\frac{dA}{dt} = \frac{dA}{dr} \cdot \frac{dr}{dt} \Rightarrow \frac{dA}{dt} = 2\pi r \cdot 20 = 40\pi r$$

Thus, the rate of change of the circle's area with respect to time, $\frac{dA}{dt}$, is a linear function in terms of the radius r .

When the radius is 50 cm, $\frac{dA}{dt} = 40\pi \cdot 50 = 2000\pi \text{ cm}^2/\text{sec}$
 $\approx 6280 \text{ cm}^2/\text{sec} [\approx 0.628 \text{ m}^2/\text{sec}]$.

When the radius is 100 cm, $\frac{dA}{dt} = 40\pi \cdot 100 = 4000\pi \text{ cm}^2/\text{sec}$
 $\approx 12600 \text{ cm}^2/\text{sec} [\approx 1.26 \text{ m}^2/\text{sec}]$.

Note that when $r = 100 \text{ cm}$ the area is changing at twice the rate it was when $r = 50 \text{ cm}$.

Example 21

A 4-metre ladder stands upright against a vertical wall. If the foot of the ladder is pulled away from the wall at a constant rate of 0.75 m/sec, how fast is the top of the ladder coming down the wall at the instant it is (i) 3 metres above the ground, and (ii) 1 metre above the ground. Give answers approximate to three significant figures.

Solution

Let x and y represent the distances of the foot and top of the ladder, respectively, from the bottom of the wall. Then from Pythagoras' theorem, we have

$$x^2 + y^2 = 16.$$

Given that the ladder is being pulled away at a rate of 0.75 m/sec, then

$$\frac{dx}{dt} = 0.75 = \frac{3}{4}.$$

So we know the rate $\frac{dx}{dt}$, and we need to find $\frac{dy}{dt}$ when $y = 3$ and when $y = 1$.

Rather than starting with the chain rule and writing an equation relating the different rates, let's utilize the chain rule by differentiating implicitly with respect to time the equation relating the relevant variables x and y .

$$\begin{aligned} \frac{d}{dt}(x^2 + y^2) &= \frac{d}{dt}(16) \\ 2x \frac{dx}{dt} + 2y \frac{dy}{dt} &= 0 \end{aligned}$$

• **Hint:** It is important to include the appropriate units when giving a rate of change (derivative) answer. For example cm/sec, m²/hour, litres/sec, etc.

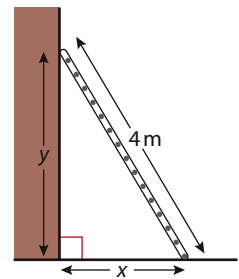

$$\frac{dy}{dt} = -\frac{x}{y} \frac{dx}{dt}$$

(i) We know $\frac{dx}{dt} = \frac{3}{4}$, so to find $\frac{dy}{dt}$ when $y = 3$ m, we find the corresponding value for x .

$$x^2 + y^2 = 16 \Rightarrow x = \sqrt{16 - y^2}; \text{ for } y = 3: x = \sqrt{16 - 3^2} = \sqrt{7}$$

Hence, when $y = 3$: $\frac{dy}{dt} = -\frac{\sqrt{7}}{3} \cdot \frac{3}{4} = -\frac{\sqrt{7}}{4} \approx -0.661$ m/sec.

(ii) For $y = 1$: $x = \sqrt{16 - 1^2} = \sqrt{15}$

Hence, when $y = 1$: $\frac{dy}{dt} = -\frac{\sqrt{15}}{1} \cdot \frac{3}{4} = -\frac{3\sqrt{15}}{4} \approx -2.90$ m/sec.

It makes sense that $\frac{dy}{dt}$ is negative because the distance y decreases as the ladders slides down.

Example 22

In the preceding example, how fast is the angle between the ladder and the ground changing when $y = 2$ m?

Solution

We know $\frac{dx}{dt} = \frac{3}{4}$ and we seek to find $\frac{d\theta}{dt}$. We need a relationship, true at any instant, between the variables θ and x . Several trigonometric ratios could be used, but perhaps the most straightforward is

$$x = 4 \cos \theta.$$

Now we differentiate implicitly with respect to t and solve for $\frac{d\theta}{dt}$.

$$\begin{aligned} \frac{d}{dt}(x) &= \frac{d}{dt}(4 \cos \theta) \\ \frac{dx}{dt} &= -4 \sin \theta \frac{d\theta}{dt} \\ \frac{d\theta}{dt} &= -\frac{1}{4 \sin \theta} \frac{dx}{dt} \end{aligned}$$

When $y = 2$ we find that $\sin \theta = \frac{1}{2}$. Substituting appropriately for $\sin \theta$ and $\frac{d\theta}{dt}$, we have

$$\frac{d\theta}{dt} = -\frac{1}{4(\frac{1}{2})} \cdot \frac{3}{4} = -\frac{3}{8}.$$

Therefore, the angle is decreasing at a rate of $\frac{3}{8}$ radians/sec (or approximately 21.5°/sec).

The solution strategy used in the preceding two examples is summarized below.

Solving problems involving related rates

1. Identify any rate(s) of change you know and the rate of change to be found.
2. Draw a diagram with all of the important information clearly labelled.
3. Write an equation relating the variables whose rates of change are either known or are to be found.
4. Using the chain rule, differentiate the equation implicitly with respect to time. Solve for the rate to be found.
5. Substitute in all known values for any variables and any rates of change. Compute the required rate of change. Be sure to include appropriate units with the result.

Example 23

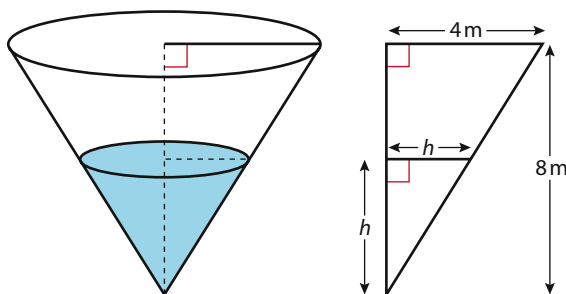

Consider a conical tank as shown in the diagram. Its radius at the top is 4 metres and its height is 8 metres. The tank is being filled with water at a rate of $2 \text{ m}^3/\text{min}$. How fast is the water level rising when it is 5 metres high?

Solution

We know the rate of change of the volume with respect to time, that is, $\frac{dV}{dt} = 2 \text{ m}^3/\text{min}$ and we seek to find the rate of change of the height of the water level with respect to time, call it $\frac{dh}{dt}$.

Not including t , there are three variables involved in this problem: V , r and h . The formula for the volume of a cone will give us an equation that relates all of these variables.

$$V = \frac{1}{3}\pi r^2 h$$

If we differentiate this equation now we will get the rate $\frac{dr}{dt}$ in our result.

We need to either find $\frac{dr}{dt}$ (which is possible) or eliminate r from the equation by solving for it in terms of one of the other variables and substitute. By using similar triangles we can write a proportion involving r and h .

$$\frac{r}{h} = \frac{4}{8} \Rightarrow r = \frac{h}{2}$$

$$\text{Hence, } V = \frac{1}{3}\pi\left(\frac{h}{2}\right)^2 h \Rightarrow V = \frac{\pi}{12}h^3.$$

Differentiating implicitly with respect to t and solving for $\frac{dh}{dt}$:

$$\frac{dV}{dt} = \frac{\pi}{12} \cdot 3h^2 \frac{dh}{dt} \Rightarrow \frac{dV}{dt} = \frac{\pi}{4}h^2 \frac{dh}{dt} \Rightarrow \frac{dh}{dt} = \frac{4}{\pi h^2} \frac{dV}{dt}$$

• **Hint:** Be careful not to substitute in known quantities too early in the process of solving a related rates problem. Substitute the known values of any variables and any rates of change *after* differentiation. For example, in Example 23 h remained a variable (it is a quantity that is changing over time) until the last stage of the solution when we substituted $h = 5$. If we substituted earlier into $V = \frac{\pi}{12}h^3$, we would have obtained $\frac{dV}{dt} = 0$, which is obviously wrong.

Substituting $h = 5$ and $\frac{dV}{dt} = 2$ gives

$$\frac{dh}{dt} = \frac{4}{\pi(5)^2} \cdot 2 = \frac{8}{25\pi} \approx 0.102 \text{ m/min [or 10.2 cm/min].}$$

Therefore, the water level is rising at a rate of 0.102 m/min when the water level is at 5 m.

The following example involves two rates of change.

Example 24

At 12 noon ship A is 65 km due north of a second ship, B. Ship A sails south at a rate of 14 km/hr, and ship B sails west at a rate of 16 km/hr.

- How fast are the two ships approaching each other $1\frac{1}{2}$ hours later at 1:30?
- At what time do the two ships stop approaching and begin moving away from each other?

Solution

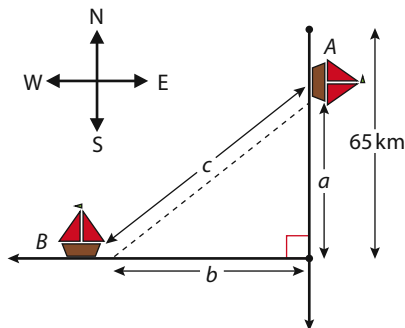

Let a and b be the distances that ships A and B, respectively, are from the intersection of the ships' paths (see diagram). Let c be the distance between the two ships. Since a is decreasing and b is increasing, we know that $\frac{da}{dt} = -14$ km/hr and $\frac{db}{dt} = 16$ km/hr.

- The three variables are related by the equation

$$c^2 = a^2 + b^2.$$

Differentiating implicitly with respect to t gives

$$2c \frac{dc}{dt} = 2a \frac{da}{dt} + 2b \frac{db}{dt}.$$

The rate at which the ships are approaching is $\frac{dc}{dt}$. Solving for $\frac{dc}{dt}$:

$$\frac{dc}{dt} = \frac{a \frac{da}{dt} + b \frac{db}{dt}}{c}$$

Substituting $\frac{da}{dt} = -14$ and $\frac{db}{dt} = 16$:

$$\frac{dc}{dt} = \frac{-14a + 16b}{c}$$

The distances a and b are both functions of time; thus, they can be written in terms of t as

$$a = 65 - 14t \text{ and } b = 16t.$$

Evaluating these expressions when $t = 1\frac{1}{2}$, gives $a = 44$, $b = 24$ and $c = \sqrt{44^2 + 24^2} \approx 50.12$. Substituting these values into the expression for $\frac{dc}{dt}$ gives

$$\frac{dc}{dt} \approx \frac{-14(44) + 16(24)}{50.12} \approx -4.629.$$

Therefore, at 1:30 the distance between the two ships is decreasing at a rate of approximately -4.63 km/hr.

- b) The time at which the two ships will stop approaching each other and begin to move away is when the value of $\frac{dc}{dt}$ changes from negative to positive. So we need to find when $\frac{dc}{dt} = 0$.

$$\frac{dc}{dt} = \frac{-14a + 16b}{c} = 0 \Rightarrow -14a + 16b = 0$$

Substituting in $a = 65 - 14t$ and $b = 16t$ gives:

$$-14(65 - 14t) + (16t) = 0 \Rightarrow 452t - 910 = 0 \Rightarrow t = \frac{910}{452} \approx 2.013$$

Therefore, just moments after 2:00 the two ships will stop approaching and start moving away from each other.

Exercise 15.4

- A water tank is in the shape of an inverted cone. Water is being drained from the tank at a constant rate of $2 \text{ m}^3/\text{min}$. (Since volume is decreasing, $\frac{dV}{dt}$ is negative.) The height of the tank is 8 m, and the diameter of the top of the tank is 6 m. When the height of the water is 5 m, find, in units of cm/min , the following:
 - the rate of change of the water level
 - the rate of change of the radius of the surface of the water.
- A spherical balloon is being inflated at a constant rate of $240 \text{ cm}^3/\text{sec}$. [$V = \frac{4}{3}\pi r^3$]
 - At what rate is the radius increasing when the radius is equal to 8 cm?
 - At what rate is the radius increasing 5 seconds after the start of inflation?
- Oil is dripping from a car engine on to a garage floor, making a growing circular stain. The radius, r , of the stain is increasing at a constant rate of $1 \text{ cm}/\text{hr}$. When the radius is 4 cm, find:
 - the rate of change of the circumference of the stain
 - the rate of change of the area of the stain.
- A hot air balloon is rising straight up from a level field at a constant rate of $50 \text{ m}/\text{min}$. An observer is standing 150 m from the point on the ground where the balloon was launched. Let θ be the angle between the ground and the observer's line of sight to the balloon from the point at which the observer is standing (angle of elevation of the balloon). What is the rate of change of θ (in radians/min) when the height of the balloon is 250 m?
- Jenny is flying a kite at a constant height above level ground of 72 m. The wind carries the kite away horizontally at a rate of $6 \text{ m}/\text{sec}$. How fast must Jenny let out the string at the moment when the kite is 120 m away from her?

- 6** A 5-foot boy is walking toward a 20-foot lamp post at a constant rate of 6 ft/sec. The light from the lamp post causes the boy to cast a shadow. How fast is the tip of his shadow moving?

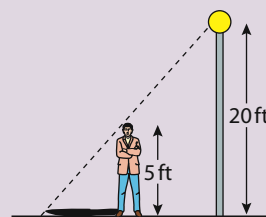

- 7** Two cars start from a point A at the same time. One travels west at 60 km/hr and the other travels north at 35 km/hr. How fast is the distance between them increasing 3 hours later?
- 8** A point moves along the curve $y = \sqrt{x^2 + 1}$ in such a way that $\frac{dx}{dt} = 4$. Find $\frac{dy}{dt}$ when $x = 3$.
- 9** A horizontal trough is 4 m long, 1.5 m wide and 1 m deep. Its cross-section is an isosceles triangle. Water is flowing into the trough at a constant rate of $0.03 \text{ m}^3/\text{sec}$. Find the rate at which the water level is rising 25 seconds after the water started flowing into the trough.

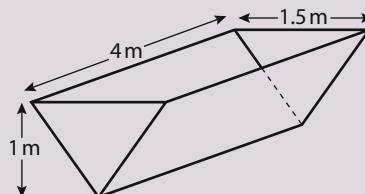

- 10** If the radius of a sphere is increasing at the constant rate of 3 mm/sec, how fast is the volume changing when the surface area is 10 mm^2 ? [Surface area = $4\pi r^2$]
- 11** Two roads, A and B, intersect each other at an angle of 60° . Two cars, one on road A travelling at 40 km/hr and the other on road B travelling at 50 km/hr, are approaching the intersection. If, at a certain moment, the two cars are both 2 km from the intersection, how fast is the distance between them changing?
- 12** If the diagonal of a cube is increasing at a rate of 8 cm/sec, how fast is a side of the cube increasing?
- 13** A point P is moving along the circle with equation $x^2 + y^2 = 100$ at a constant rate of 3 units/sec. How fast is the projection of P on the x -axis moving when P is 5 units above the x -axis?
- 14** A jet is flying at a constant speed at an altitude of 10 000 m on a path that will take it directly over an observer on the ground. At a given instant the observer determines that the angle of elevation of the jet is $\frac{\pi}{3}$ radians and is increasing at a constant rate of $\frac{1}{60}$ radians/sec. Find the speed of the jet.
- 15** A television cameraman is filming an automobile race from a platform that is 40 metres from the racing track, following a car that is moving at 288 km/hr. How fast, in degrees per second, will the camera be turning when a) the car is directly in front of the camera and b) a half second later? Answer to the nearest whole degree.
- 16** A plane is flying due east at 640 km/hr and climbing vertically at a rate of 180 m/min. An airport tower is tracking it. Determine how fast the distance between the plane and the tower is changing when the plane is 5 km above the ground over a point exactly 6 km due west of the tower. Express the answer in km/hr.

15.5 Optimization

Many problems in science and mathematics involve finding the maximum or minimum value (**optimum** value) of a function over a specified or implied domain. The development of the calculus in the seventeenth century was motivated to a large extent by maxima and minima (**optimization**) problems. One such problem led Pierre de Fermat (1601–1665) to develop his Principle of Least Time: a ray of light will follow the path that takes the least (or minimum) time. The solution to Fermat's principle led to Snell's law, or law of refraction (see the investigation at the end of this section). The solution is found by applying techniques of differential calculus – which can also be used to solve other optimization problems involving ideas such as least cost, maximum profit, minimum surface area and greatest volume.

Previously, we learned the theory of how to use the derivative of a function to locate points where the function has a maximum or minimum (i.e. extreme) value. It is important to remember that if the derivative of a function is zero at a certain point it does not *necessarily* follow that the function has an extreme value (relative or absolute) at that point – it only ensures that the function has a horizontal tangent (stationary point) at that point. An extreme value *may* occur where the derivative is zero or at the endpoints of the function's domain.

The graph of $f(x) = x^4 - 8x^3 + 18x^2 - 16x - 2$ is shown left. The derivative of $f(x)$ is $f'(x) = 4x^3 - 24x^2 + 36x - 16 = 4(x - 4)(x - 1)^2$. The function has horizontal tangents at both $x = 1$ and $x = 4$, since the derivative is zero at these points. However, an extreme value (absolute minimum) occurs only at $x = 4$. It is important to confirm – graphically (see GDC images) or algebraically – the precise nature of a point on a function where the derivative is zero. Some different algebraic methods for confirming that a value is a maximum or minimum will be illustrated in the examples that follow.

It is also useful to remember that one can often find extreme values (extrema) without calculus (e.g. using a 'minimum' command on a graphics calculator, as shown). Calculator or computer technology can be very helpful in modelling, solving or confirming solutions to optimization problems. However, it is important to learn how to apply algebraic methods of differentiation to optimization problems because it may be the only efficient way to obtain an accurate solution.

Let's start with a relatively straightforward example. We can use the steps in the solution to develop a general strategy that can be applied to more sophisticated problems.

Example 25 – Finding a maximum area (Developing a general strategy)

Find the maximum area of a rectangle inscribed in an isosceles right triangle whose hypotenuse is 20 cm long.

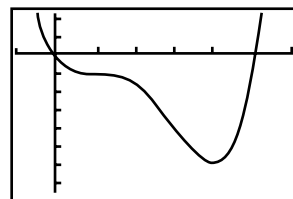

CALCULATE
 1: value
 2: zero
 3: minimum
 4: maximum
 5: intersect
 6: dy/dx
 7: ∫ f(x) dx

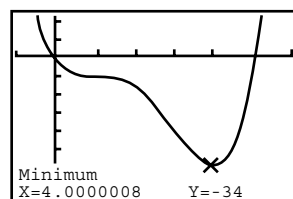

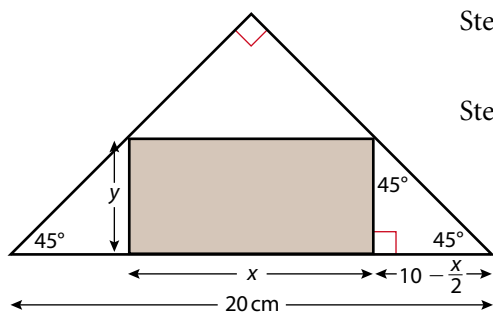
Solution

Step 1: Draw an accurate diagram. Let the base of the rectangle be x cm and the height y cm. Then the area of the rectangle is $A = xy$ cm².

Step 2: Express area as a function in terms of only one variable.

It can be deduced from the diagram that $y = 10 - \frac{x}{2}$.

Therefore, $A(x) = x\left(10 - \frac{x}{2}\right) = 10x - \frac{x^2}{2}$.

x must be positive and from the diagram it is clear that x must be less than 20 (domain of A : $0 < x < 20$).

Step 3: Find the derivative of the area function and find for what value(s) of x it is zero.

$$A'(x) = 10 - x \quad A'(x) = 0 \text{ when } x = 10$$

Step 4: Analyze $A(x)$ at $x = 10$ and also at the endpoints of the domain, $x = 0$ and $x = 20$.

The second derivative test (Section 13.3) provides information about the concavity of a function. The second derivative is $A''(x) = -1$ and since $A''(x)$ is always negative then $A(x)$ is always concave down, indicating $A(x)$ has a maximum at $x = 10$.

$A(0) = 0$ and $A(20) = 0$, indicating $A(x)$ has an absolute maximum at $x = 10$.

Therefore, the rectangle has a maximum area equal to

$$A(10) = 10\left(10 - \frac{10}{2}\right) = 50 \text{ cm}^2.$$

General strategy for solving optimization problems

Step 1: Draw a diagram that accurately illustrates the problem. Label all known parts of the diagram. Using variables, label the important unknown quantity (or quantities) (for example, x for base and y for height in Example 25).

Step 2: For the quantity that is to be optimized (area in Example 25), express this quantity as a function in terms of a single variable. From the diagram and/or information provided, determine the domain of this function.

Step 3: Find the derivative of the function from Step 2, and determine where the derivative is zero. This value (or values) of the derivative, along with any domain endpoints, are the **critical values** ($x = 0$, $x = 10$ and $x = 20$ in Example 25) to be tested.

Step 4: Using algebraic (e.g. second derivative test) or graphical (e.g. GDC) methods, analyze the nature (maximum, minimum, neither) of the points at the critical values for the optimized function. Be sure to answer the precise question that was asked in the problem.

Example 26 – Finding a minimum length – two posts problem

Two vertical posts, with heights of 7 m and 13 m, are secured by a rope going from the top of one post to a point on the ground between the posts and then to the top of the other post. The distance between the two posts is 25 m. Where should the point at which the rope touches the ground be located so that the least amount of rope is used?

Solution

Step 1: An accurate diagram is drawn. The posts are drawn as line segments PQ and TS and the point where the rope touches the ground is labelled R . The optimum location of point R can be given as a distance from the base of the shorter post, QR , or from the taller post, SR . It is decided to give the answer as the distance from the shorter post – and this is labelled x . There are two other important unknown quantities: the lengths of the two portions of the rope, PR and TR . These are labelled a and b , respectively.

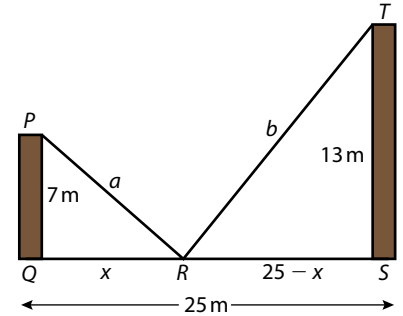

Step 2: The quantity to be minimized is the length L of the rope, which is the sum of a and b . From Pythagoras' theorem, $a = \sqrt{x^2 + 49}$ and $b = \sqrt{(25 - x)^2 + 169}$. Therefore, the function for length (L) can be expressed in terms of the single variable x as

$$\begin{aligned} L(x) &= \sqrt{x^2 + 49} + \sqrt{(25 - x)^2 + 169} \\ &= \sqrt{x^2 + 49} + \sqrt{x^2 - 50x + 625 + 169} \\ L(x) &= \sqrt{x^2 + 49} + \sqrt{x^2 - 50x + 794} \end{aligned}$$

From the given information and diagram, the domain of $L(x)$ is $0 \leq x \leq 25$.

Step 3: To facilitate differentiation, express $L(x)$ using fractional exponents:

$$L(x) = (x^2 + 49)^{\frac{1}{2}} + (x^2 - 50x + 794)^{\frac{1}{2}}$$

Then apply the chain rule for differentiation:

$$\frac{dL}{dx} = \frac{1}{2}(x^2 + 49)^{-\frac{1}{2}}(2x) + \frac{1}{2}(x^2 - 50x + 794)^{-\frac{1}{2}}(2x - 50) \Rightarrow$$

$$\frac{dL}{dx} = \frac{x}{\sqrt{x^2 + 49}} + \frac{x - 25}{\sqrt{x^2 - 50x + 794}}$$

By setting $\frac{dL}{dx} = 0$, we obtain

$$x\sqrt{x^2 - 50x + 794} = -(x - 25)\sqrt{x^2 + 49}$$

$$x^2(x^2 - 50x + 794) = (25 - x)^2(x^2 + 49)$$

$$x^4 - 50x^3 + 794x^2 = x^4 - 50x^3 + 674x^2 - 2450x + 30\,625$$

$$120x^2 + 2450x - 30\,625 = 0$$

$$5(4x - 35)(6x + 175) = 0$$

$$x = \frac{35}{4} \quad \text{or} \quad x = -\frac{175}{6}$$

Step 4: Since $x = -\frac{175}{6}$ is not in the domain for $L(x)$, then the critical values are $x = 0$, $x = \frac{35}{4}$ and $x = 25$. Simply evaluate $L(x)$ for these critical values.

$$L(0) = 7 + \sqrt{794} \approx 35.18, \quad L(25) = \sqrt{674} + 13 \approx 38.96,$$

$$L\left(\frac{35}{4}\right) = 5\sqrt{41} \approx 32.02$$

Therefore, the rope should touch the ground at a distance of $\frac{35}{4} = 8.75$ m from the base of the shorter post, to give a minimum rope length of approximately 32.02 m.

The minimum value could also be confirmed from the graph of $L(x)$, but it would be difficult to confirm using the second derivative test because of the algebra required. From this example, we can see that applied optimization problems can involve a high level of algebra. If you have access to suitable graphing technology, you could perform Steps 3 and 4 graphically rather than algebraically.

```
Plot1 Plot2 Plot3
\Y1=√(X²+49)+√(X
²-50X+794)
\Y2=
\Y3=
\Y4=
\Y5=
\Y6=
```

```
WINDOW
Xmin=0
Xmax=25
Xscl=5
Ymin=0
Ymax=40
Yscl=5
Xres=1
```

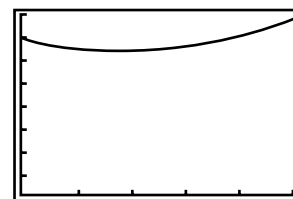

```
CALCULATE
1:value
2:zero
3:minimum
4:maximum
5:intersect
6:dy/dx
7:∫f(x)dx
```

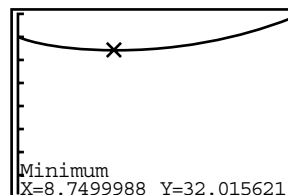

It is interesting to observe that the result for x produced by the calculator does not appear to be exact. Why is that? Algebraic techniques using differentiation give us the certainty of an exact solution while also allowing us to deal with the abstract nature of optimization problems involving parameters rather than fixed measurements (e.g. the heights of the posts).

In both Example 25 and 26, the extreme value occurred at a point where the derivative was zero. Although this often happens, an extreme value may occur at the endpoint of the domain.

Example 27 – An endpoint maximum

A supply of four metres of wire is to be used to form a square and a circle. How much of the wire should be used to make the square and how much should be used to make the circle in order to enclose the greatest amount of area? Guess the answer before looking at the following solution.

Solution

Step 1: Let x = length of each edge of the square and r = radius of the circle.

Step 2: The total area is given by $A = x^2 + \pi r^2$. The task is to write the area A as a function of a single variable. Therefore, it is necessary to express r in terms of x , or vice versa, and perform a substitution.

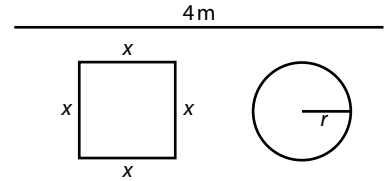

The perimeter of the square is $4x$ and the circumference of the circle is $2\pi r$. The total amount of wire is 4 m which gives

$$4 = 4x + 2\pi r \Rightarrow 2\pi r = 4 - 4x \Rightarrow r = \frac{2(1 - x)}{\pi}$$

$$\text{Substituting gives } A(x) = x^2 + \pi \left[\frac{2(1 - x)}{\pi} \right]^2 = x^2 + \frac{4(1 - x)^2}{\pi} \\ = \frac{1}{\pi} [(\pi + 4)x^2 - 8x + 4]$$

Because the square's perimeter is $4x$, then the domain for $A(x)$ is $0 \leq x \leq 1$.

Step 3: Differentiate the function $A(x)$, set equal to zero, and solve.

$$\frac{d}{dx} \left(\frac{1}{\pi} [(\pi + 4)x^2 - 8x + 4] \right) = \frac{1}{\pi} [2(\pi + 4)x - 8] = 0$$

$$2(\pi + 4)x - 8 = 0 \Rightarrow (\pi + 4)x = 4 \Rightarrow x = \frac{4}{\pi + 4} \approx 0.5601$$

The critical values are $x = 0$, $x \approx 0.5601$ and $x = 1$.

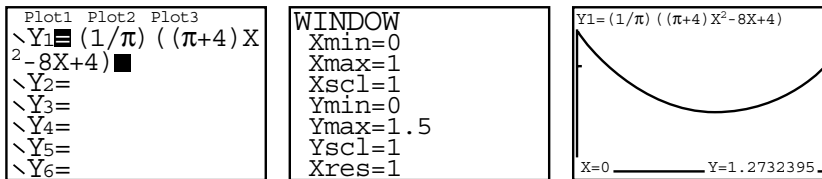

Step 4: Evaluating $A(x)$: $A(0) \approx 1.273$, $A(0.5601) \approx 0.5601$ and $A(1) = 1$.

Therefore, the maximum area occurs when $x = 0$ which means all the wire is used for the circle.

What would the answer be if Example 27 asked for the dimensions of the square and circle to enclose the *least* total area?

Example 28 – Minimizing time

A pipeline needs to be constructed to link an offshore drilling rig to an onshore refinery depot. The oil rig is located at a distance (perpendicular to the coast) of 140 km from the coast. The depot is located inland at a distance (perpendicular) of 60 km from the coast. For modelling purposes, the coastline is assumed to follow a straight line. The point on the coastline nearest to the oil rig is 160 km from the point on the coastline nearest to the depot. The rate at which crude oil is pumped through the pipeline varies according to several variables, including pipe dimensions, materials, temperature, etc. On average, oil flows through the offshore section of the pipeline at a rate of 9 km per hour and 5 km per hour through the onshore section. Assume that both sections of pipeline can travel straight from one point to another. At what point should the pipeline intersect with the coastline in order for the oil to take a minimum amount of time to flow from the rig to the depot?

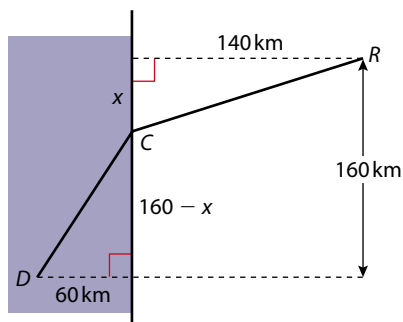
**Solution**

Step 1: The optimum location of the point, C , where the pipeline comes ashore will be designated by the distance, x , it is from the point on the coast that is a minimum distance (perpendicular) from the rig, R (140 km). The distance from R to C is $\sqrt{x^2 + 140^2}$ and the distance from D (depot) to C is $\sqrt{(160 - x)^2 + 60^2}$.

Step 2: The quantity to be minimized is time, so it is necessary to express the total time it takes the oil to flow from R to D in terms of a single variable.

$$\text{time} = \frac{\text{distance}}{\text{rate}} \Rightarrow \text{time (offshore)} = \frac{\sqrt{x^2 + 19\,600} \text{ km}}{9 \text{ km/hr}};$$

$$\text{time (onshore)} = \frac{\sqrt{x^2 - 320x + 29\,200} \text{ km}}{5 \text{ km/hr}}$$

The function for time T in terms of x is:

$$T(x) = \frac{\sqrt{x^2 + 19\,600}}{9} + \frac{\sqrt{x^2 - 320x + 29\,200}}{5}$$

and the domain for $T(x)$ is $0 \leq x \leq 160$.

Steps 3/4: The algebra for finding the derivative of $T(x)$ is similar to that of Step 3 in Example 26. Let's use graphing technology to find the value of x that produces a minimum for $T(x)$.

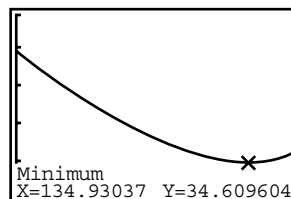
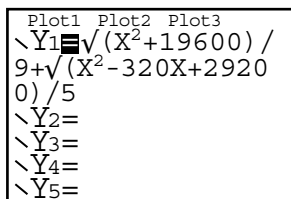

Therefore, the optimum point for the pipeline to intersect with the coast is approximately 134.9 km from the point on the coast nearest to the drilling rig.

The result could also be obtained by having a calculator or computer graph the derivative of $T(x)$ and compute any zeros for $T'(x)$ in the domain.

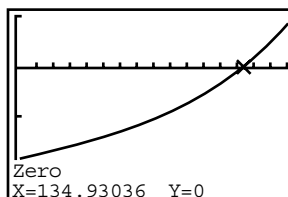
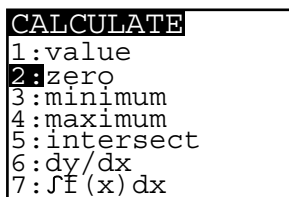
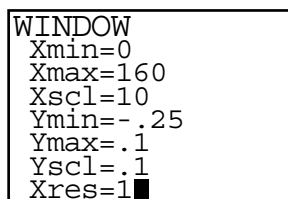
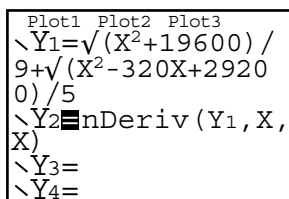

See the **Investigation** and how solving a problem similar to Example 28 derives Snell's law (or law of refraction).

Investigation – Snell’s law

The speed of light depends on the medium through which light travels and is generally slower in denser media. The speed of light in a vacuum is an important physical constant and is exactly 299 792 458 m/s. A metre is defined to be the distance that light travels in a vacuum in $\frac{1}{299\,792\,458}$ of a second.

Typically, the speed of light in a vacuum (denoted by the letter c) is given the approximate value of 3×10^8 m/s, but in the Earth’s atmosphere light travels more slowly than that and even more slowly through glass and water.

Fermat’s principle in optics states that light travels from one point to another along a path for which time is a minimum. Investigate the path that a ray of light will follow in going from a point A in a transparent medium, where the speed of light is c_1 , to a point B in a different transparent medium, where its speed is c_2 , as illustrated in the diagram left. Using algebra and differentiation, prove that for time to be a minimum the following relationship must hold:

$\frac{\sin \theta_1}{c_1} = \frac{\sin \theta_2}{c_2}$. This equation is known as Snell’s law or the law of refraction. Why is a graphics calculator not helpful?

Assume that the two points, A and B , lie in the xy -plane and the x -axis (interface) separates the two media. A light ray is refracted (deflected) when it passes from one medium to another. θ_1 is the **angle of incidence** and θ_2 is the **angle of refraction** (both angles measured between ray and normal to the interface).

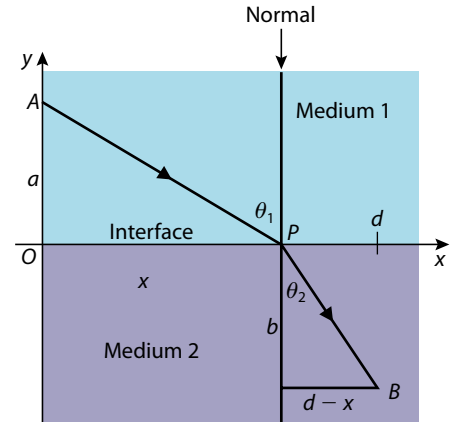

Exercise 15.5

- Find the dimensions of the rectangle with maximum area that is inscribed in a semicircle with radius 1 cm. Two vertices of the rectangle are on the semicircle and the other two vertices are on the x -axis, as shown in the diagram.

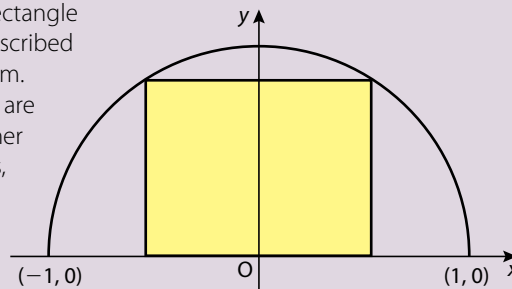

- A rectangular piece of aluminium is to be rolled to make a cylinder with open ends (a tube). Regardless of the dimensions of the rectangle, the perimeter of the rectangle must be 40 cm. Find the dimensions (length and width) of the rectangle that gives a maximum volume for the cylinder.
- Find the minimum distance from the graph of the function $y = \sqrt{x}$ and the point $(\frac{3}{2}, 0)$.
- A rectangular box has height h cm, width x cm and length $2x$ cm. It is designed to have a volume equal to 1 litre (1000 cm^3).
 - Show that $h = \frac{500}{x^2}$ cm.
 - Find an expression for the total surface area, $S \text{ cm}^2$, of the box in terms of x .
 - Find the dimensions of the box that produces a minimum surface area.

- 5 The figure right consists of a rectangle $ABCD$ and two semicircles on either end. The rectangle has an area of 100 cm^2 . If x represents the length of the rectangle AB , find the value of x that makes the perimeter of the entire figure a minimum.

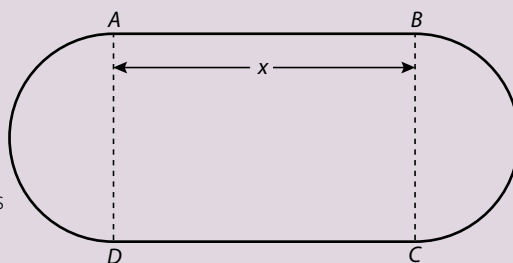

- 6 Two vertical posts, with heights 12 metres and 8 metres, are 10 metres apart on horizontal ground. A rope that stretches is attached to the top of both posts and is stretched down so that it touches the ground at point A between the two posts. The distance from the base of the taller post to point A is represented by x and the angle between the two sections of rope is θ . What value of x makes θ a maximum?

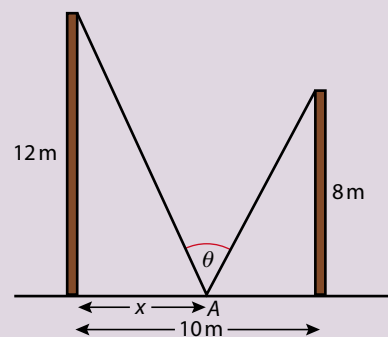

- 7 A ladder is to be carried horizontally down an L-shaped hallway. The first section of the hallway is 2 metres wide and then there is a right-angled turn into a 3-metre wide section. What is the longest ladder that can be carried around the corner?

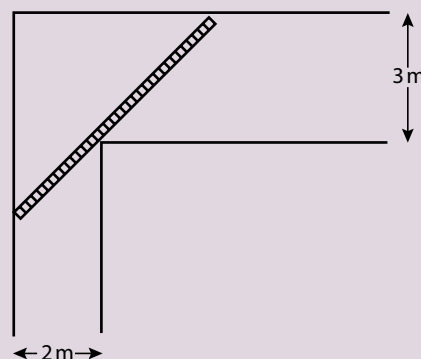

- 8 Charlie is walking from the wildlife observation tower (point T) to the Big Desert Park office (point O). The tower is 7 km due west and 10 km due south from the office. There is a road that goes to the office that Charlie can get to if she walks 10 km due north from the tower. Charlie can walk at a rate of 2 kilometres per hour (kph) through the sandy terrain of the park, but she can walk a faster rate of 5 kph on the road. To what point, A , on the road should Charlie walk to in order to take the least time to walk from the tower to the office? Find the value of d such that point A is d km from the office.

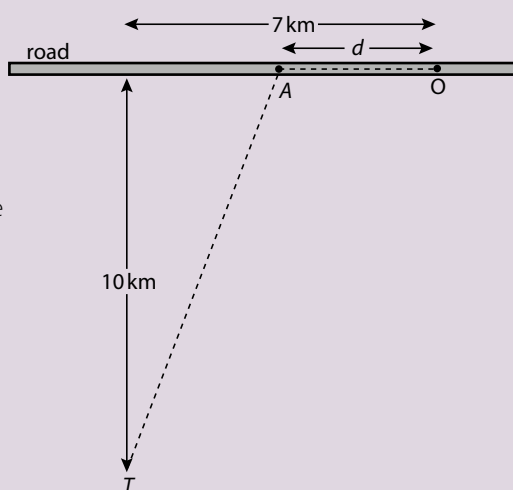

- 9 Two vertices of a rectangle are on the x -axis, and the other two vertices are on the curve $y = \frac{8}{x^2 + 4}$. (See Exercise 15.1, question 12.) Find the maximum area of the rectangle.

• **Hint:** Write an equation for θ in terms of x and find the value of x which makes θ a maximum by using your GDC.

- 10 A ship sailing due south at 16 knots is 10 nautical miles north of a second ship going due west at 12 knots. Find the minimum distance between the two ships.
- 11 Find the height, h , and the base radius, r , of the largest right circular cylinder that can be made by cutting it away from a sphere with a radius of R .

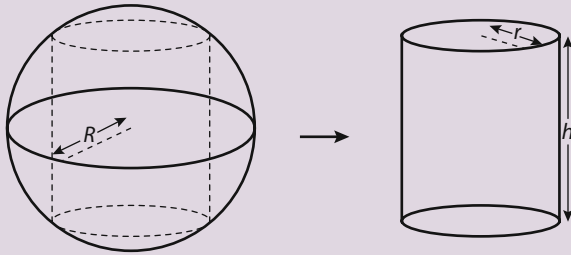

- 12 Nadia is standing at point A that is a km away in the countryside from a straight road XY (see diagram). She wishes to reach the point Y where the distance from X to Y is b km. Her speed on the road is r km/hr and her speed travelling across the countryside is c km/hr, such that $r > c$. If she wishes to reach Y as quickly as possible, find the position of point P where she joins the road.

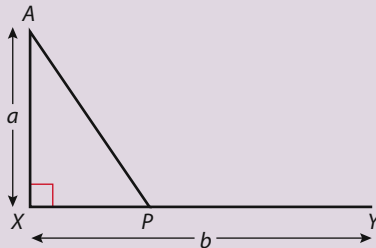

- 13 A cone of height h and radius r is constructed from a circle with radius 10 cm by removing a sector AOC of arc length x cm and then connecting the edges OA and OC . What arc length x will produce the cone of maximum volume, and what is the volume?

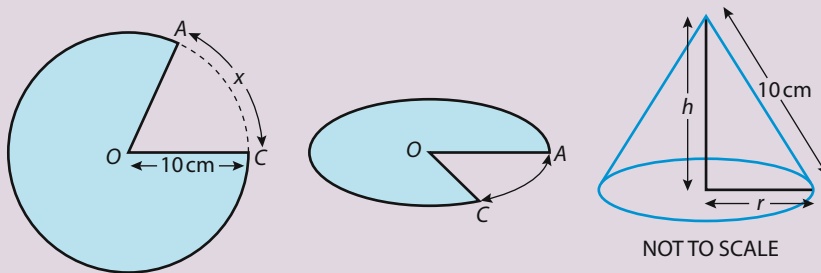

- 14 Point P is a units above the line AB , and point Q is b units below line AB (see diagram). The velocity of light is u units/second above AB and v units/second below AB , and $u > v$. The angles α and β are the angles that a ray of light makes with a perpendicular (normal) to line AB above and below AB , respectively. Show that the following relationship must hold true.

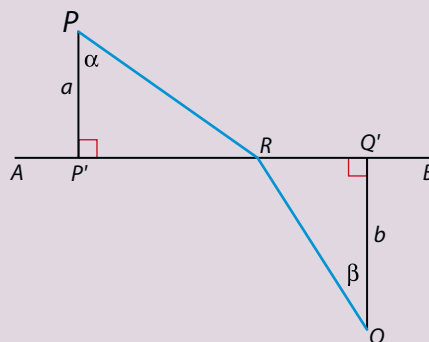

$$\frac{\sin \alpha}{\sin \beta} = \frac{u}{v}$$

Practice questions

- 1 The diagram shows the graph of $y = f(x)$.

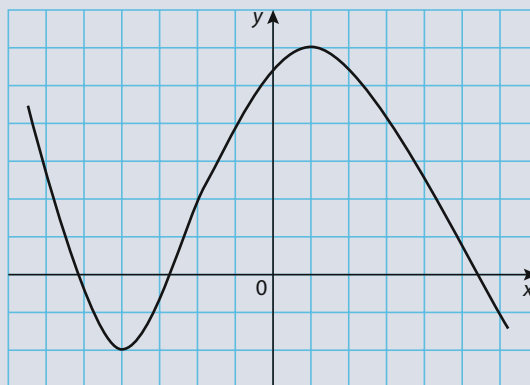

Copy the grid right and sketch the graph of $y = f'(x)$.

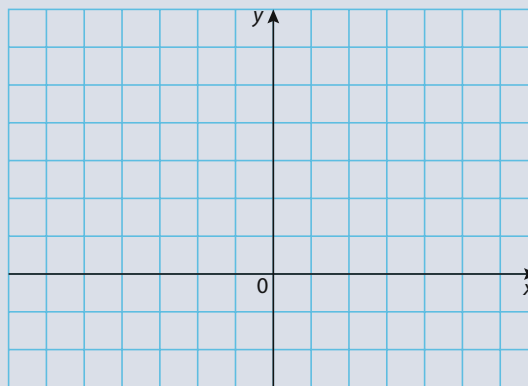

- 2 The diagram right shows part of the graph of the function $f: x \mapsto -x^3 - 2x^2 + 8x$.

The graph intersects the x -axis at $(-4, 0)$, $(0, 0)$ and $(2, 0)$. There is a minimum point at C and a maximum point at D .

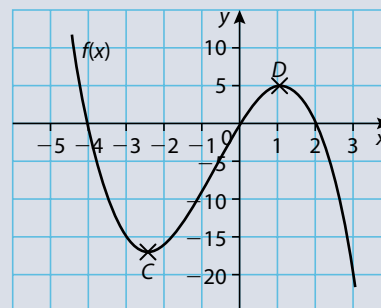

- a) The function may also be written in the form $f: x \mapsto -x(x-a)(x-b)$, where $a < b$. Write down the value of
- (i) a (ii) b .
- b) Find
- (i) $f'(x)$
- (ii) the exact values of x at which $f'(x) = 0$
- (iii) the value of the function at D .
- c) (i) Find the equation of the tangent to the graph of f at $(0, 0)$.
- (ii) This tangent cuts the graph of f at another point. Give the x -coordinate of this point.

- 3 In a controlled experiment, a tennis ball is dropped from the uppermost observation deck (447 metres high) of the CN Tower in Toronto.

The tennis ball's velocity is given by

$$v(t) = 66 - 66e^{-0.15t}$$

where v is in metres per second and t is in seconds.





- a) Find the value of v when
(i) $t = 0$ (ii) $t = 10$.
- b) (i) Find an expression for the acceleration, a , as a function of t .
(ii) What is the value of a when $t = 0$?
- c) (i) As t becomes large, what value does v approach?
(ii) As t becomes large, what value does a approach?
(iii) Explain the relationship between the answers to parts c(i) and (ii).
- 4 Given the function $f(x) = x^3 + 7x^2 + 8x - 3$,
a) identify any points as a relative maximum or minimum and find their exact coordinates
b) find the exact coordinates of any inflexion point(s).
- 5 Consider the function $g(x) = 2 + \frac{1}{e^{3x}}$.
a) (i) Find $g'(x)$.
(ii) Explain briefly how this shows that $g(x)$ is a decreasing function for all values of x (i.e. that $g(x)$ always decreases in value as x increases).
Let P be the point on the graph of g where $x = -\frac{1}{3}$.
b) Find an expression in terms of e for
(i) the y -coordinate of P
(ii) the gradient of the tangent to the curve at P .
c) Find the equation of the tangent to the curve at P , giving your answer in the form $y = mx + c$.
- 6 Consider the function f given by $f(x) = \frac{2x^2 - 13x + 20}{(x - 1)^2}$, $x \neq 1$.
a) Show that $f'(x) = \frac{9x - 27}{(x - 1)^3}$, $x \neq 1$.
The second derivative is given by $f''(x) = \frac{72 - 18x}{(x - 1)^4}$, $x \neq 1$.
b) Using values of $f'(x)$ and $f''(x)$, explain why a minimum must occur at $x = 3$.
c) There is a point of inflexion on the graph of f . Write down the coordinates of this point.
- 7 Differentiate with respect to x :
a) $y = \frac{1}{(2x + 3)^2}$
b) $y = e^{\sin 5x}$
c) $y = \tan^2(x^2)$
- 8 The curve with equation $y = Ax + B + \frac{C}{x}$, $x \in \mathbb{R}$, $x \neq 0$, has a minimum at $P(1, 4)$ and a maximum at $Q(-1, 0)$. Find the value of each of the constants A , B and C .
- 9 Find $\frac{dy}{dx}$ and $\frac{d^2y}{dx^2}$ at the point $(1, 1)$ on the curve $x^3 + y^3 = 2$.
- 10 Differentiate with respect to x :
a) $y = \frac{x}{e^x - 1}$ b) $y = e^x \sin 2x$ c) $y = (x^2 - 1) \ln(3x)$
- 11 The normal to the curve $y = x^2 - 4x$ at the point $(3, -3)$ intersects the x -axis at point P and the y -axis at point Q . Find the equation of the normal and the coordinates of P and Q .

- 12 Let $y = h(x)$ be a function of x for $0 \leq x \leq 6$. The graph of h has an inflexion point at P and a maximum point at M . Partial sketches of the curves of $h'(x)$ and $h''(x)$ are shown below.

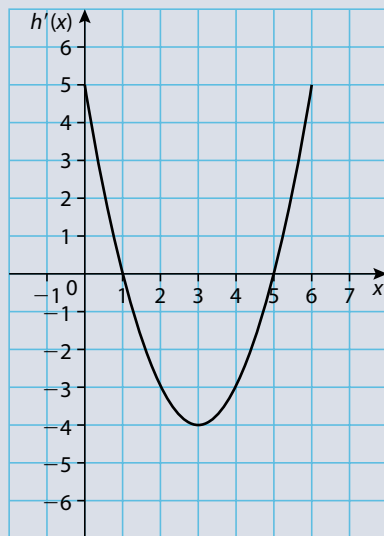
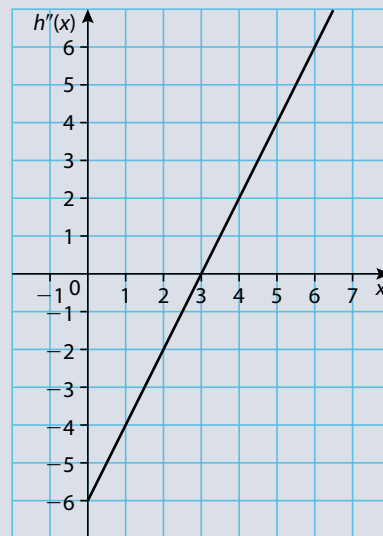
 $y = h'(x)$  $y = h''(x)$

Use the above information to answer the following.

- Write down the x -coordinate of P and justify your answer.
 - Write down the x -coordinate of M and justify your answer.
 - Given that $h(3) = 0$, sketch the graph of h . On the sketch, mark the points P and M .
- 13 Find the equation of the normal to the curve $x^2 + xy + y^2 - 3y = 10$ at the point $(2, 3)$.

- 14 A cylinder is to be made with an exact volume of $128\pi \text{ cm}^3$.

What should be the height h and the radius r of the cylinder's base so that the cylinder's surface area is a minimum?

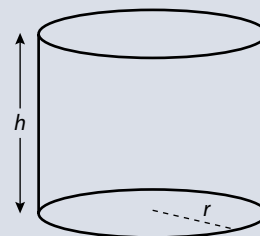

- 15 A rectangle has its base on the x -axis and its upper two vertices on the parabola $y = 12 - x^2$, as shown in the diagram. What is the largest area that the rectangle can have, and what are its dimensions (i.e. length and width)?

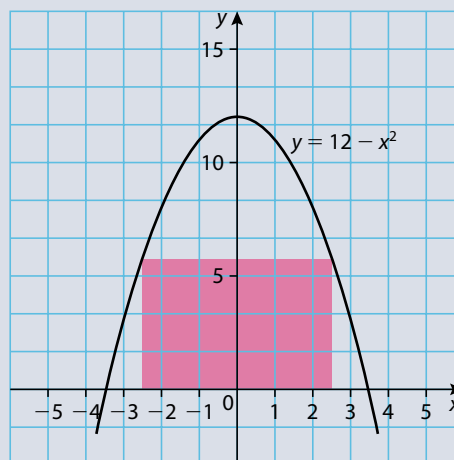

16 The figure below shows the graph of a function $y = f(x)$. At which one of the five points on the graph:

- are $f'(x)$ and $f''(x)$ both negative?
- is $f'(x)$ negative and $f''(x)$ positive?
- is $f'(x)$ positive and $f''(x)$ negative?

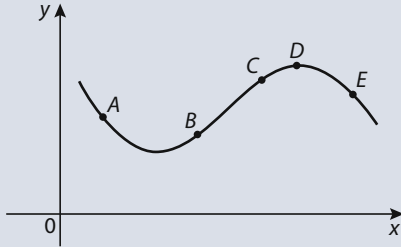

17 Find the equation of the normal to the curve with equation $y = \frac{2x - 1}{x + 2}$ at the point $(-3, 7)$.

18 Find the equation of a) the tangent, and b) the normal to the curve $y = \ln(4x - 3)$ at the point $(1, 0)$.

19 Consider the function $f(x) = x^2 \ln x$.

- Find the exact coordinates of any stationary points. Indicate whether it is a maximum or minimum (and absolute or relative).
- Find the exact coordinates of any inflexion points.

20 a) Determine the constant a such that the function $f(x) = x^2 + \frac{a}{x}$ has (i) a local minimum at $x = 2$ and (ii) a local minimum at $x = -3$.

- Show that the function cannot have a local maximum for any value of a .

21 A line passes through the point $(3, 2)$ and intersects both the x -axis and the y -axis, forming a triangular region in the first quadrant bounded by the x -axis, the y -axis and the line. Find the equation of such a line that creates a triangle of minimum area.

22 Find the equation of both the tangent and normal to the curve $y = x \tan x$ at the point where $x = \frac{\pi}{4}$.

23 A very important function in statistics is the equation for the **standard normal curve**

(mean = 0, standard deviation = 1) given by $f(x) = \frac{e^{-\frac{x^2}{2}}}{\sqrt{2\pi}}$.

- Find the coordinates of any stationary points and of any inflexion points.
- What happens when $x \rightarrow \infty$, and when $x \rightarrow -\infty$? Give the equation for any asymptotes.
- Sketch a graph of $f(x)$ and indicate the location of any of the points found in part a).

24 Let f be the function given by $f(x) = 2 \ln(x^2 + 3) - x$.

- Find the x -coordinate of each maximum and minimum point of f . Justify your answer(s).
- Find the x -coordinate of each inflexion point of f . Justify your answer(s).

25 The rate at which cars on a road pass a certain point is known as the flow rate and is in units of cars per hour. The flow rate, F , of a certain road is given by

$F(x) = \frac{2x}{18 + 0.015x^2}$ where x is the speed of the traffic in kilometres per hour. What

speed will maximise the flow rate on the road?

- 26 If $2x^2 - 3y^2 = 2$, find the two values of $\frac{dy}{dx}$ when $x = 5$.
- 27 Differentiate $y = \arccos(1 - 2x^2)$ with respect to x , and simplify your answer.
- 28 For the function $f: x \mapsto x^2 \ln x$, $x > 0$, find the function f' , the derivative of f with respect to x .
- 29 For the function $f: x \mapsto \frac{1}{2} \sin 2x + \cos x$, find the possible values of $\sin x$ for which $f'(x) = 0$.
- 30 Find the gradient of the tangent to the curve $3x^2 + 4y^2 = 7$ at the point where $x = 1$ and $y > 0$.
- 31 If $f(x) = \ln(2x - 1)$, $x > \frac{1}{2}$, find
- $f'(x)$
 - the value of x where the gradient of $f(x)$ is equal to x .
- 32 Find the x -coordinate, between -2 and 0 , of the point of inflexion on the graph of the function $f: x \mapsto x^2 e^x$. Give your answer to 3 decimal places.
- 33 A normal to the graph of $y = \arctan(x - 1)$, for $x > 0$, has equation $y = -2x + c$, where $c \in \mathbb{R}$. Find the value of c .
- 34 The function f is given by $f: x \mapsto e^{1 + \sin \pi x}$, $x \geq 0$.
- Find $f'(x)$.

Let x_n be the value of x where the $(n + 1)$ th maximum or minimum point occurs, $n \in \{N\}$ (i.e. x_0 is the value of x where the first maximum or minimum occurs, x_1 is the value of x where the second maximum or minimum occurs, etc.).

- Find x_n in terms of n .
- 35 Let $f(x) = x^3 \sqrt{x^2 - 1}$, $-1.4 \leq x \leq 1.4$.
- Sketch** the graph of $f(x)$. (An exact scale diagram is **not** required.)
On your graph indicate the approximate position of
 - each zero
 - each maximum point
 - each minimum point.
 - Find $f'(x)$, clearly stating its domain.
 - Find the x -coordinates of the maximum and minimum points of $f(x)$, for $-1 < x < 1$.
 - Find the x -coordinate of the point of inflexion of $f(x)$, where $x > 0$, giving your answer correct to **four** decimal places.
- 36 The line $y = 16x - 9$ is a tangent to the curve $y = 2x^3 + ax^2 + bx - 9$ at the point $(1, 7)$. Find the values of a and b .
- 37 Consider the function $y = \tan x - 8 \sin x$.
- Find $\frac{dy}{dx}$.
 - Find the value of $\cos x$ for which $\frac{dy}{dx} = 0$.
- 38 Consider the tangent to the curve $y = x^3 + 4x^2 + x - 6$.
- Find the equation of this tangent at the point where $x = -1$.
 - Find the coordinates of the point where this tangent meets the curve again.
- 39 Let $y = \sin(kx) - kx \cos(kx)$, where k is a constant.
Show that $\frac{dy}{dx} = k^2 x \sin(kx)$.

40 A curve has equation $xy^3 + 2x^2y = 3$. Find the equation of the tangent to this curve at the point $(1, 1)$.

41 The function f is defined by

$$f(x) = \frac{x^2 - x + 1}{x^2 + x + 1}.$$

- a) (i) Find an expression for $f'(x)$, simplifying your answer.
 (ii) The tangents to the curve of $f(x)$ at points A and B are parallel to the x -axis. Find the coordinates of A and of B .
- b) (i) Sketch the graph of $y = f'(x)$.
 (ii) Find the x -coordinates of the three points of inflexion on the graph of f .
- c) Find the range of
 (i) f
 (ii) the composite function $f \circ f$.

42 Air is pumped into a spherical ball which expands at a rate of 8 cm^3 per second ($8 \text{ cm}^3 \text{ s}^{-1}$). Find the **exact** rate of increase of the radius of the ball when the radius is 2 cm .

43 A curve has equation $x^3y^2 = 8$. Find the equation of the normal to the curve at the point $(2, 1)$.

44 The function f is defined by $f(x) = \frac{x^2}{2^x}$, for $x > 0$.

a) (i) Show that

$$f'(x) = \frac{2x - x^2 \ln 2}{2^x}.$$

- (ii) Obtain an expression for $f''(x)$, simplifying your answer as far as possible.
- b) (i) Find the exact value of x satisfying the equation $f'(x) = 0$.
 (ii) Show that this value gives a maximum value for $f(x)$.
- c) Find the x -coordinates of the two points of inflexion on the graph of f .

45 Consider the function $f(t) = 3 \sec^2 t + 5t$.

- a) Find $f'(t)$.
 b) Find the **exact** values of
 (i) $f(\pi)$
 (ii) $f'(\pi)$.

46 Consider the equation $2xy^2 = x^2y + 3$.

- a) Find y when $x = 1$ and $y < 0$.
 b) Find $\frac{dy}{dx}$ when $x = 1$ and $y < 0$.

47 Let $y = e^{3x} \sin(\pi x)$.

- a) Find $\frac{dy}{dx}$.
 b) Find the smallest positive value of x for which $\frac{dy}{dx} = 0$.

48 An airplane is flying at a constant speed at a constant altitude of 3 km in a straight line that will take it directly over an observer at ground level. At a given instant the observer notes that the angle θ is $\frac{1}{3}\pi$ radians and is increasing at $\frac{1}{60}$ radians per second. Find the speed, in kilometres per hour, at which the airplane is moving towards the observer.

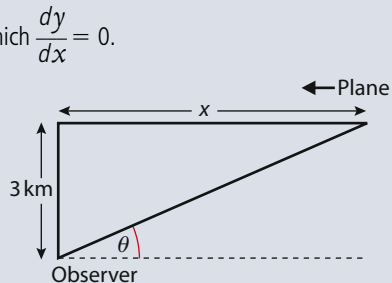

49 A curve has equation $f(x) = \frac{a}{b + e^{-cx}}$, $a \neq 0$, $b > 0$, $c > 0$.

a) Show that $f''(x) = \frac{ac^2e^{-cx}(e^{-cx} - b)}{(b + e^{-cx})^3}$.

b) Find the coordinates of the point on the curve where $f''(x) = 0$.

c) Show that this is a point of inflexion.

50 The point $P(1, p)$, where $p > 0$, lies on the curve $2x^2y + 3y^2 = 16$.

a) Calculate the value of p .

b) Calculate the gradient of the tangent to the curve at P .

51 The function f is defined by $f: x \mapsto 3^x$.

Find the solution of the equation $f''(x) = 2$.

52 The following diagram shows an isosceles triangle ABC with $AB = 10$ cm and

$AC = BC$. The vertex C is moving in a direction perpendicular to (AB) with speed 2 cm per second.

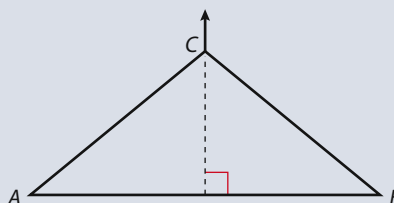

Calculate the rate of increase of the angle \widehat{CAB} at the moment the triangle is equilateral.

53 If $y = \ln(2x - 1)$, find $\frac{d^2y}{dx^2}$.

54 Find the equation of the normal to the curve $x^3 + y^3 - 9xy = 0$ at the point $(2, 4)$.

55 The function f' is given by $f'(x) = 2 \sin\left(5x - \frac{\pi}{2}\right)$.

a) Write down $f''(x)$.

b) Given that $f\left(\frac{\pi}{2}\right) = 1$, find $f(x)$.

56 Find the gradient of the normal to the curve $3x^2y + 2xy^2 = 2$ at the point $(1, -2)$.

57 The function f is given by $f(x) = \frac{x^5 + 2}{x}$, $x \neq 0$. There is a point of inflexion on the graph of f at the point P . Find the coordinates of P .

58 An experiment is carried out in which the number n of bacteria in a liquid is given

by the formula $n = 650e^{kt}$, where t is the time in minutes after the beginning of the experiment and k is a constant. The number of bacteria doubles every 20 minutes. Find

a) the **exact** value of k

b) the rate at which the number of bacteria is increasing when $t = 90$.

59 Let f be a cubic polynomial function. Given that $f(0) = 2$, $f'(0) = -3$, $f(1) = f'(1)$ and $f''(-1) = 6$, find $f(x)$.

60 Let $f(x) = \cos^3(4x + 1)$, $0 \leq x \leq 1$.

a) Find $f'(x)$.

b) Find the **exact** values of the three roots of $f'(x) = 0$.

- 61 Given that $3^{x+y} = x^3 + 3y$, find $\frac{dy}{dx}$.
- 62 Let f be the function defined for $x > -\frac{1}{3}$ by $f(x) = \ln(3x + 1)$.
- Find $f'(x)$.
 - Find the equation of the normal to the curve $y = f(x)$ at the point where $x = 2$.
- Give your answer in the form $y = ax + b$ where $a, b \in \mathbb{R}$.
- 63 Let $y = x \arcsin x$, $x \in (-1, 1)$. Show that $\frac{d^2y}{dx^2} = \frac{2-x^2}{(1-x^2)^{\frac{3}{2}}}$.
- 64 Given that $e^{xy} - y^2 \ln x = e$ for $x \geq 1$, find $\frac{dy}{dx}$ at the point $(1, 1)$.
- 65 The function f is defined by $f(x) = \frac{2x}{x^2 + 6}$ for $x \geq b$ where $b \in \mathbb{R}$.
- Show that $f'(x) = \frac{12 - 2x^2}{(x^2 + 6)^2}$.
 - Hence, find the smallest exact value of b for which the inverse function f^{-1} exists. Justify your answer.
- 66 Consider the curve with equation $x^2 + xy + y^2 = 3$.
- Find in terms of k , the gradient of the curve at the point $(-1, k)$.
 - Given that the tangent to the curve is parallel to the x -axis at this point, find the value of k .
- 67 Find the gradient of the tangent to the curve $x^3y^2 = \cos(\pi y)$ at the point $(-1, 1)$.

- 68 André wants to get from point A located in the sea to point Y located on a straight stretch of beach. P is the point on the beach nearest to A such that $AP = 2$ km and $PY = 2$ km. He does this by swimming in a straight line to a point Q located on the beach and then running to Y.

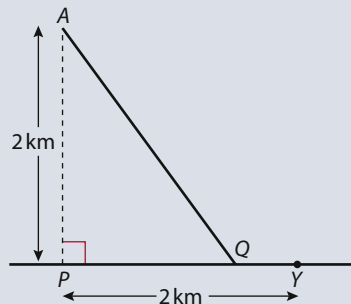

When André swims he covers 1 km in $5\sqrt{5}$ minutes. When he runs he covers 1 km in 5 minutes.

- If $PQ = x$ km, $0 \leq x \leq 2$, find an expression for the time T minutes taken by André to reach point Y.
- Show that $\frac{dT}{dx} = \frac{5\sqrt{5}x}{\sqrt{x^2 + 4}} - 5$.
- Solve $\frac{dT}{dx} = 0$.
 - Use the value of x found in **part c (i)** to determine the time, T minutes, taken for André to reach point Y.
 - Show that $\frac{d^2T}{dx^2} = \frac{20\sqrt{5}}{(x^2 + 4)^{\frac{3}{2}}}$ and hence show that the time found in **part c** is a minimum.

69 The function f is defined by $f(x) = xe^{2x}$.

It can be shown that $f^{(n)}(x) = (2^n x + n^{2^n-1})e^{2x}$ for all $n \in \mathbb{Z}^+$, where $f^{(n)}(x)$ represents the n th derivative of $f(x)$.

- By considering $f^{(n)}(x)$ for $n = 1$ and $n = 2$, show that there is one minimum point P on the graph of f , and find the coordinates of P .
- Show that f has a point of inflexion Q at $x = -1$.
- Determine the intervals on the domain of f where f is
 - concave up
 - concave down.
- Sketch f' , clearly showing any intercepts, asymptotes and the points P and Q .
- Use mathematical induction to prove that $f^{(n)}(x) = (2^n x + n^{2^n-1})e^{2x}$ for all $n \in \mathbb{Z}^+$, where $f^{(n)}(x)$ represents the n th derivative of $f(x)$.

70 The diagram below shows the boundary of the cross-section of a water channel.

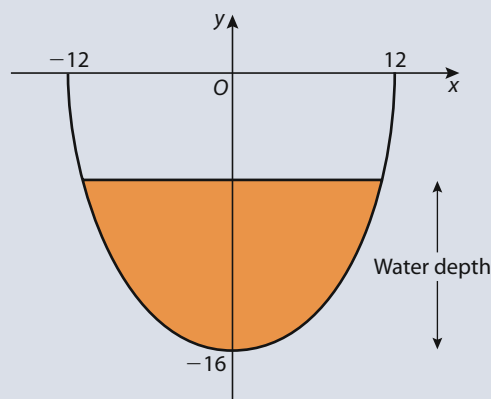

The equation that represents this boundary is $y = 16 \sec\left(\frac{\pi x}{36}\right) - 32$ where x and y are both measured in cm.

The top of the channel is level with the ground and has a width of 24 cm. The maximum depth of the channel is 16 cm.

Find the width of the water surface in the channel when the water depth is 10 cm. Give your answer in the form $a \arccos b$ where $a, b \in \mathbb{R}$.

71 The graphs given below are those of the same function $y = f(x)$ for $a \leq x \leq b$.

Sketch, on the given axes, the graphs of **a)** $\frac{dy}{dx}$ and **b)** $\frac{d^2y}{dx^2}$.

Indicate clearly the positions of any asymptotes.

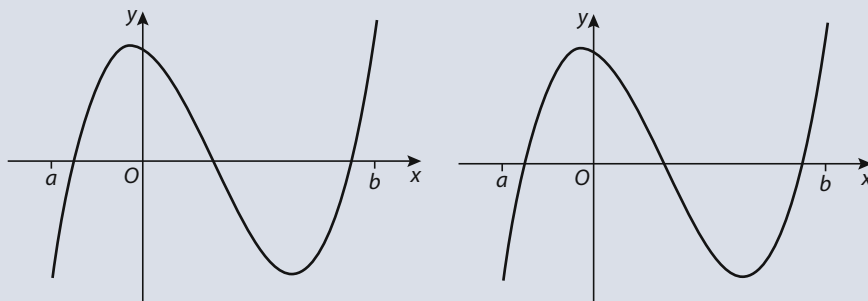

Assessment statements

- 6.4 Indefinite integration as anti-differentiation.
Indefinite integral of x^n , $\sin x$, $\cos x$, $1/x$ and e^x .
The composites of any of these with a linear function.
- 6.5 Anti-differentiation with a boundary condition to determine the constant term.
Definite integrals.
Area of the region enclosed by a curve and the x -axis or y -axis in a given interval.
Areas of regions enclosed by curves.
Volumes of revolution about the x -axis or y -axis.
- 6.6 Kinematic problems involving displacement s , velocity v and acceleration a .
Total distance travelled.
- 6.7 Further integration: integration by substitution; integration by parts.

Introduction

In Chapters 13 and 15 you learned about the process of differentiation. That is, given a function, how you can find its derivative. In this chapter, we will look at the reverse process. That is, given a function $f(x)$, how can we find a function $F(x)$ whose derivative is $f(x)$. This process is the opposite of differentiation and is therefore called **anti-differentiation**.

16.1 Anti-derivative

An **anti-derivative** of the function $f(x)$ is a function $F(x)$ such that

$$\frac{d}{dx}F(x) = F'(x) = f(x) \text{ wherever } f(x) \text{ is defined.}$$

For instance, let $f(x) = x^2$. It is not difficult to discover an anti-derivative of $f(x)$. Keep in mind that this is a power function. Since the power rule reduces the power of the function by 1, we examine the derivative of x^3 :

$$\frac{d}{dx}(x^3) = 3x^2.$$

This derivative, however, is 3 times $f(x)$. To 'compensate' for the 'extra' 3, we have to multiply by $\frac{1}{3}$, so that the anti-derivative is now $\frac{1}{3}x^3$. Now,

$$\frac{d}{dx}\left(\frac{1}{3}x^3\right) = x^2.$$

And, therefore, $\frac{1}{3}x^3$ is an anti-derivative of x^2 .

Table 16.1 shows some examples of functions, each paired with one of its anti-derivatives.

Table 16.1

Function $f(x)$	Anti-derivative $F(x)$
1	x
x	$\frac{x^2}{2}$
$3x^2$	x^3
x^4	$\frac{x^5}{5}$
$\cos x$	$\sin x$
$\cos 2x$	$\frac{1}{2}\sin 2x$
e^x	e^x
$\sin x$	$-\cos x$
$2x$	x^2

The diagrams below show the relationship between the derivative and the integral as opposite operations.

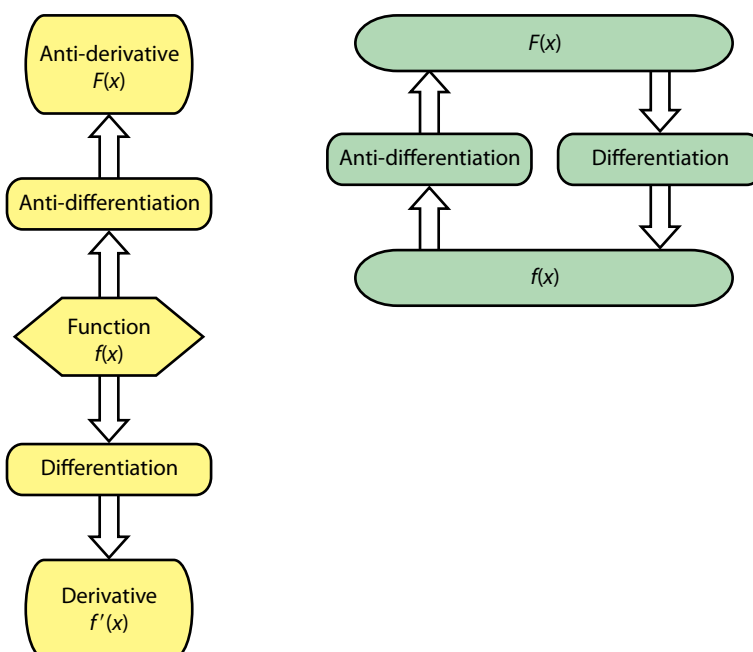

Example 1

Given the function $f(x) = 3x^2$, find an anti-derivative of $f(x)$.

Solution

$F_1(x) = x^3$ is such an anti-derivative because $\frac{d}{dx}(F_1(x)) = 3x^2$.

The following functions are also anti-derivatives because the derivative of each one of them is also $3x^2$.

$$H_1(x) = x^3 + 27, H_2(x) = x^3 - \pi, \text{ or } H_3(x) = x^3 + \sqrt{5}$$

Indeed, $F(x) = x^3 + c$ is an anti-derivative of $f(x) = 3x^2$ for any choice of the constant c .

This is so simply because

$$(F(x) + c)' = F'(x) + c' = F'(x) + 0 = f(x)!$$

Thus, we can say that any single function $f(x)$ has many anti-derivatives, whereas a function can have only one derivative.

If $F(x)$ is an anti-derivative of $f(x)$, then so is $F(x) + c$ for any choice of the constant c .

Stated slightly differently, this observation says:

If $F(x)$ is an anti-derivative of $f(x)$ over a certain interval I , then every anti-derivative of $f(x)$ on I is of the form $F(x) + c$.

This statement is an indirect conclusion of one of the results of the mean value theorem.

Two functions with the same derivative on an interval differ only by a constant on that interval.

We will state the mean value theorem here in order to establish the general rule for anti-derivatives.

Mean value theorem

A function $H(x)$, continuous over an interval $[a, b]$ and differentiable over $]a, b[$, satisfies

$$H(b) - H(a) = (b - a)H'(c) \text{ for some } c \in]a, b[.$$

Let $F(x)$ and $G(x)$ be any anti-derivatives of $f(x)$, i.e. $F'(x) = G'(x)$.

Take $H(x) = F(x) - G(x)$ and any two numbers x_1 and x_2 in the interval $[a, b]$ such that $x_1 < x_2$, then

$$\begin{aligned} H(x_2) - H(x_1) &= (x_2 - x_1)H'(c) = (x_2 - x_1) \cdot (F'(c) - G'(c)) \\ &= (x_2 - x_1) \cdot 0 = 0 \Rightarrow H(x_1) = H(x_2) \end{aligned}$$

which means that $H(x)$ is a constant function.

Hence, $H(x) = F(x) - G(x) = \text{constant}$. That is, any two anti-derivatives of a function differ by a constant.

Notation:

The notation

$$\int f(x) dx = F(x) + c \quad (1)$$

where c is an arbitrary constant, means that $F(x) + c$ is an anti-derivative of $f(x)$.

Equivalently, $F(x)$ satisfies the condition that

$$\frac{d}{dx}(F(x)) = F'(x) = f(x) \quad (2)$$

for all x in the domain of $f(x)$.

It is important to note that (1) and (2) are just different notations to express the same fact. For example,

$$\int x^2 dx = \frac{1}{3}x^3 + c \text{ is equivalent to } \frac{d}{dx}\left(\frac{1}{3}x^3\right) = x^2.$$

Note that if we differentiate an anti-derivative of $f(x)$, we obtain $f(x)$ back again.

$$\text{Thus, } \frac{d}{dx}(\int f(x) dx) = f(x).$$

The expression $\int f(x) dx$ is called an **indefinite integral** of $f(x)$. The function $f(x)$ is called the **integrand** and the constant c is called the **constant of integration**.

The integral symbol \int is made like an elongated capital S. It is, in fact, a medieval S, used by Leibniz as an abbreviation for the Latin word *summa*.

We think of the combination $\int [\] dx$ as a single symbol; we fill in the 'blank' with the formula of the function whose anti-derivative we seek. We may regard the differential **dx** as specifying the independent variable x both in the function $f(x)$ and in its anti-derivatives.

If an independent variable other than x is used, say t , the notation must be adjusted appropriately.

$$\text{Thus, } \frac{d}{dt}(\int f(t) dt) = f(t) \text{ and } \int f(t) dt = F(t) + c \text{ are equivalent statements.}$$



Derivative formula	Equivalent integration formula
$\frac{d}{dx}(x^3) = 3x^2$	$\int 3x^2 dx = x^3 + c$
$\frac{d}{dx}(\sqrt{x}) = \frac{1}{2\sqrt{x}}$	$\int \frac{1}{2\sqrt{x}} dx = \sqrt{x} + c$
$\frac{d}{dt}(\tan t) = \sec^2 t$	$\int \sec^2 t dt = \tan t + c$
$\frac{d}{dv}(v^{\frac{3}{2}}) = \frac{3}{2}v^{\frac{1}{2}}$	$\int \frac{3}{2}v^{\frac{1}{2}} dv = v^{\frac{3}{2}} + c$



Note: The integral sign and differential serve as delimiters, adjoining the integrand on the left and right, respectively. In particular, we do not write $\int dx f(x)$ when we mean $\int f(x) dx$.

Basic integration formulae

Integration is essentially educated guesswork – given the derivative $f(x)$ of a function $F(x)$, we try to guess what the function $F(x)$ is. However, many basic integration formulae can be obtained directly from their companion differentiation formulae. Some of the most important are given in Table 16.2.

Table 16.2

	Differentiation formula	Integration formula
1	$\frac{d}{dx}(x) = 1$	$\int dx = x + c$
2	$\frac{d}{dx}(x^{n+1}) = (n+1)x^n, n \neq -1$	$\int x^n dx = \frac{x^{n+1}}{n+1} + c, n \neq -1$
3	$\frac{d}{dx}(\sin x) = \cos x$	$\int \cos x dx = \sin x + c$
4	$\frac{d}{dx}(\cos x) = -\sin x$	$\int \sin v dv = -\cos v + c$
5	$\frac{d}{dt}(\tan t) = \sec^2 t$	$\int \sec^2 t dt = \tan t + c$
6	$\frac{d}{dv}(e^v) = e^v$	$\int e^v dv = e^v + c$
7	$\frac{d}{dx}(\ln x) = \frac{1}{x}$	$\int \frac{1}{x} dx = \ln x + c$
8	$\frac{d}{dx}\left(\frac{a^x}{\ln a}\right) = a^x$	$\int a^x dx = \frac{1}{\ln a} a^x + c$
9	$\frac{d}{dx}(\arcsin x) = \frac{1}{\sqrt{1-x^2}}$	$\int \frac{dx}{\sqrt{1-x^2}} = \arcsin x + c$
10	$\frac{d}{dx}(\arctan x) = \frac{1}{1+x^2}$	$\int \frac{dx}{1+x^2} = \arctan x + c$

Formula (7) is a special case of the ‘power’ rule formula (2), but needs some modification.

If we are given the task to integrate $\frac{1}{x}$, we may attempt to do it using the power rule:

$$\int \frac{1}{x} dx = \int x^{-1} dx = \frac{1}{(-1)+1} x^{(-1)+1} + c = \frac{1}{0} x^0 + c, \text{ which is undefined.}$$

However, the solution is clearly found by observing what you learned in Chapter 15.

In Section 15.3 you learned that

$$\frac{d}{dx}(\ln x) = \frac{1}{x}, \quad x > 0.$$

This implies

$$\int \frac{1}{x} dx = \ln x + c, \quad x > 0.$$

However, the function $\frac{1}{x}$ is differentiable for $x < 0$ too. So, we must be able to find its integral.

The solution lies in the chain rule!

If $x < 0$, we can write $x = -u$ where $u > 0$. Then $dx = -du$, and

$$\int \frac{1}{x} dx = \int \frac{1}{-u} (-du) = \int \frac{1}{u} du = \ln u + c, \quad u > 0.$$

But $u = -x$, therefore when $x < 0$

$$\int \frac{1}{x} dx = \ln u + c = \ln(-x) + c, \text{ and, combining the two results, we have}$$

$$\int \frac{1}{x} dx = \ln|x| + c, \quad x \neq 0.$$

Suppose that $f(x)$ and $g(x)$ are differentiable functions and k is a constant, then:

1. A constant factor can be moved through an integral sign, i.e.

$$\int kf(x) dx = k \int f(x) dx$$

2. An anti-derivative of a sum (difference) is the sum (difference) of the anti-derivatives, i.e.

$$\int (f(x) + g(x)) dx = \int f(x) dx + \int g(x) dx, \text{ or } \int (f(x) - g(x)) dx = \int f(x) dx - \int g(x) dx$$

Example 2

Evaluate:

a) $\int 3 \cos x \, dx$

b) $\int (x^3 + x^2) \, dx$

Solution

a) $\int 3 \cos x \, dx = 3 \int \cos x \, dx = 3 \sin x + c$

b) $\int (x^3 + x^2) \, dx = \int x^3 \, dx + \int x^2 \, dx = \frac{x^4}{4} + \frac{x^3}{3} + c$

Sometimes it is useful to rewrite the integrand in a different form before performing the integration.

Example 3

Evaluate:

a) $\int \frac{t^3 - 3t^5}{t^5} \, dt$

b) $\int \frac{x + 5x^4}{x^2} \, dx$

Solution

a) $\int \frac{t^3 - 3t^5}{t^5} \, dt = \int \frac{t^3}{t^5} \, dt - \int \frac{3t^5}{t^5} \, dt = \int t^{-2} \, dt - \int 3 \, dt = \frac{t^{-1}}{-1} - 3t + c$
 $= -\frac{1}{t} - 3t + c$

b) $\int \frac{x + 5x^4}{x^2} \, dx = \int \frac{x}{x^2} \, dx + \int \frac{5x^4}{x^2} \, dx = \int \frac{1}{x} \, dx + \int 5x^2 \, dx = \ln|x| + 5 \cdot \frac{x^3}{3} + c$

Integration by simple substitution

In this section, we will study a technique called substitution that can often be used to transform complicated integration problems into simpler ones.

The method of substitution depends on our understanding of the chain rule as well as the use of variables in integration. Two facts to recall:

1. When we find an anti-derivative, we established earlier that the use of x is arbitrary. We can use any other variable as you have seen in several exercises and examples so far.

So, $\int f(u) du = F(u) + c$, where u is a 'dummy' variable in the sense that it can be replaced by any other variable.

2. The chain rule enables us to say

$$\frac{d}{dx}(F(u(x))) = F'(u(x)) \cdot u'(x).$$

This can be written in integral form as

$$\int F'(u(x)) \cdot u'(x) dx = F(u(x)) + c$$

or, equivalently, since $F(x)$ is an anti-derivative of $f(x)$,

$$\int f(u(x)) \cdot u'(x) dx = F(u(x)) + c.$$

For our purposes, it will be useful and simpler to let $u(x) = u$ and to write

$\frac{du}{dx} = u'(x)$ in its 'differential' form $du = u'(x) dx$, or, simply, $du = u' dx$.

With this notation, the integral can now be written as

$$\int f(u(x)) \cdot u'(x) dx = \int f(u) du = F(u) + c.$$

The following example explains how the method works.

Example 4

Evaluate:

- | | |
|--|-------------------------------|
| a) $\int (x^3 + 2)^{10} \cdot 3x^2 dx$ | b) $\int \tan x dx$ |
| c) $\int \cos 5x dx$ | d) $\int \cos x^2 \cdot x dx$ |
| e) $\int e^{3x+1} dx$ | |

Solution

- a) To integrate this function, it is simplest to make the following substitution.

Let $u = x^3 + 2$, and so $du = 3x^2 dx$. Now the integral can be written as

$$\int (x^3 + 2)^{10} \cdot 3x^2 dx = \int u^{10} du = \frac{u^{11}}{11} + c = \frac{(x^3 + 2)^{11}}{11} + c.$$

- b) This integrand has to be rewritten first and then we make the substitution.

$$\int \tan x dx = \int \frac{\sin x}{\cos x} dx = \int \frac{1}{\cos x} \cdot \sin x dx$$

We now let $u = \cos x \Rightarrow du = -\sin x dx$, and

$$\int \tan x dx = \int \frac{1}{\cos x} \cdot \sin x dx = \int \frac{1}{u} \cdot (-du) = -\int \frac{1}{u} du = -\ln|u| + c.$$

c) Let $u = 3x - 5$, then $du = 3dx$, and

$$\begin{aligned}\int 2 \sin(3x - 5) dx &= 2 \cdot \frac{1}{3} \int \sin(3x - 5) 3dx = \frac{2}{3} \int \sin u du \\ &= -\frac{2}{3} \cos u + c = -\frac{2}{3} \cos(3x - 5) + c.\end{aligned}$$

d) Let $u = mx + n$, then $du = m dx$, and

$$\begin{aligned}\int e^{mx+n} dx &= \frac{1}{m} \int e^{mx+n} m dx = \frac{1}{m} \int e^u du \\ &= \frac{1}{m} e^u + c = \frac{1}{m} e^{mx+n} + c.\end{aligned}$$

e) $F(x) = \int x\sqrt{x} dx = \int x^{\frac{3}{2}} dx = \frac{x^{\frac{5}{2}}}{(\frac{5}{2})} + c = \frac{2}{5} x^{\frac{5}{2}} + c$, but $F(1) = 2$

$$F(1) = \frac{2}{5} 1^{\frac{5}{2}} + c = \frac{2}{5} + c = 2 \Rightarrow c = \frac{8}{5}$$

$$\text{Therefore, } F(x) = \frac{2}{5} x^{\frac{5}{2}} + \frac{8}{5}.$$

The previous discussion makes it clear that Table 16.2 is limited in scope, because we cannot use the integrals directly to evaluate composite integrals such as the ones in Examples 4 and 5 above. An adjusted table is therefore presented here.

Table 16.3

	Differentiation formula	Integration formula
1	$\frac{d}{dx}(u(x)) = u'(x) \Rightarrow du = u'(x)dx$	$\int du = u + c$
2	$\frac{d}{dx}\left(\frac{u^{n+1}}{n+1}\right) = u^n u'(x), n \neq -1 \Rightarrow d\left(\frac{u^{n+1}}{n+1}\right) = u^n u'(x)dx$	$\int u^n du = \frac{u^{n+1}}{n+1} + c, n \neq -1$
3	$\frac{d}{dx}(\sin(u)) = \cos(u)u'(x) \Rightarrow d(\sin(u)) = \cos(u)u'(x)dx$	$\int \cos u du = \sin u + c$
4	$\frac{d}{dx}(-\cos(u)) = \sin(u)u'(x) \Rightarrow d(-\cos(u)) = \sin(u)u'(x)dx$	$\int \sin u du = -\cos u + c$
5	$\frac{d}{dt}(\tan u) = \sec^2 u u'(t) \Rightarrow d(\tan u) = \sec^2 u u'(t)dt$	$\int \sec^2 u du = \tan u + c$
6	$\frac{d}{dx}(e^u) = e^u u'(x)dx \Rightarrow d(e^u) = e^u u'(x)dx$	$\int e^u du = e^u + c$
7	$\frac{d}{dx}(\ln u) = \frac{1}{u}u'(x) \Rightarrow d(\ln u) = \frac{1}{u}u'(x)dx$	$\int \frac{1}{u} du = \ln u + c$
8	$\frac{d}{dx}\left(\frac{a^u}{\ln a}\right) = a^u u'(x) \Rightarrow d\left(\frac{a^u}{\ln a}\right) = a^u u'(x)dx$	$\int a^u du = \frac{a^u}{\ln a} + c$
9	$\frac{d}{dx}(\arcsin u) = \frac{1}{\sqrt{1-u^2}}u'(x) \Rightarrow d(\arcsin u) = \frac{1}{\sqrt{1-u^2}}u'(x)dx$	$\int \frac{du}{\sqrt{1-u^2}} = \arcsin u + c$
10	$\frac{d}{dx}(\arctan u) = \frac{1}{1+u^2}u'(x) \Rightarrow d(\arctan u) = \frac{1}{1+u^2}u'(x)dx$	$\int \frac{du}{1+u^2} = \arctan u + c$

Example 6

Evaluate each integral.

a) $\int \sqrt{6x + 11} dx$

b) $\int (5x^3 + 2)^8 x^2 dx$

c) $\int \frac{x^3 - 2}{\sqrt[5]{x^4 - 8x + 13}} dx$

d) $\int \sin^4(3x^2) \cos(3x^2) x dx$

Solution

a) We let $u = 6x + 11$ and calculate du :

$$u = 6x + 11 \Rightarrow du = 6dx$$

Since du contains the factor 6, the integral is still not in the proper form $\int f(u) du$. However, here we can use of two approaches:

(i) Introduce the factor 6, as we have done before, i.e.

$$\begin{aligned} \int \sqrt{6x + 11} dx &= \frac{1}{6} \int \sqrt{6x + 11} \boxed{6dx} \\ &= \frac{1}{6} \int \sqrt{u} \boxed{du} = \frac{1}{6} \int u^{\frac{1}{2}} du \\ &= \frac{1}{6} \frac{u^{\frac{3}{2}}}{\frac{3}{2}} + c = \frac{2}{18} u^{\frac{3}{2}} + c \\ &= \frac{1}{9} (6x + 11)^{\frac{3}{2}} + c \end{aligned}$$

Or,

(ii) Since $u = 6x + 11 \Rightarrow du = 6dx \Rightarrow dx = \frac{du}{6}$, then

$$\int \sqrt{6x + 11} dx = \int \sqrt{u} \frac{du}{6} = \frac{1}{6} \int u^{\frac{1}{2}} du, \text{ then we follow the same steps as before.}$$

b) We let $u = 5x^3 + 2$, then $du = 15x^2 dx$. This means that we need to introduce the factor 15 into the integrand:

$$\begin{aligned} \int (5x^3 + 2)^8 x^2 dx &= \frac{1}{15} \int (5x^3 + 2)^8 15x^2 dx \\ &= \frac{1}{15} \int u^8 du = \frac{1}{15} \frac{u^9}{9} + c \\ &= \frac{1}{135} (5x^3 + 2)^9 + c \end{aligned}$$

c) We let $u = x^4 - 8x + 13 \Rightarrow du = (4x^3 - 8) dx = 4(x^3 - 2) dx$.

$$\begin{aligned} \int \frac{x^3 - 2}{\sqrt[5]{x^4 - 8x + 13}} dx &= \frac{1}{4} \int \frac{4(x^3 - 2) dx}{\sqrt[5]{x^4 - 8x + 13}} = \frac{1}{4} \int \frac{du}{u^{\frac{1}{5}}} \\ &= \frac{1}{4} u^{-\frac{1}{5}} du = \frac{1}{4} \frac{u^{\frac{4}{5}}}{\frac{4}{5}} + c \\ &= \frac{5}{16} (x^4 - 8x + 13)^{\frac{4}{5}} + c \end{aligned}$$

d) We let $u = \sin(3x^2) \Rightarrow du = \cos(3x^2)6x dx$ using the chain rule!

$$\begin{aligned}\int \sin^4(3x^2)\cos(3x^2)x dx &= \frac{1}{6}\int \sin^4(3x^2)\cos(3x^2)6x dx \\ &= \frac{1}{6}\int u^4 du = \frac{1}{6} \frac{u^5}{5} + c \\ &= \frac{1}{30} \sin^5(3x^2) + c\end{aligned}$$

Exercise 16.1

In questions 1–15, find the most general anti-derivative of the function.

1 $f(x) = x + 2$

2 $f(t) = 3t^2 - 2t + 1$

3 $g(x) = \frac{1}{3} - \frac{2}{7}x^3$

4 $f(t) = (t - 1)(2t + 3)$

5 $g(u) = u^{\frac{2}{5}} - 4u^3$

6 $f(x) = 2\sqrt{x} - \frac{3}{2\sqrt{x}}$

7 $h(\theta) = 3 \sin \theta + 4 \cos \theta$

8 $f(t) = 3t^2 - 2 \sin t$

9 $f(x) = \sqrt{x}(2x - 5)$

10 $g(\theta) = 3 \cos \theta - 2 \sec^2 \theta$

11 $h(t) = e^{3t-1}$

12 $f(t) = \frac{2}{t}$

13 $h(t) = \frac{t}{3t^2 + 5}$

14 $h(\theta) = e^{\sin \theta} \cos \theta$

15 $f(x) = (3 + 2x)^2$

In questions 16–20, find f .

16 $f''(x) = 4x - 15x^2$

17 $f''(x) = 1 + 3x^2 - 4x^3; f'(0) = 2, f(1) = 2$

18 $f''(t) = 8t - \sin t$

19 $f'(x) = 12x^3 - 8x + 7, f(0) = 3$

20 $f'(\theta) = 2 \cos \theta - \sin(2\theta)$

In questions 21–50, evaluate each integral.

21 $\int x(3x^2 + 7)^5 dx$

22 $\int \frac{x}{(3x^2 + 5)^4} dx$

23 $\int 2x^2 \sqrt[4]{5x^3 + 2} dx$

24 $\int \frac{(3 + 2\sqrt{x})^5}{\sqrt{x}} dx$

25 $\int t^2 \sqrt{2t^3 - 7} dt$

26 $\int \left(2 + \frac{3}{x}\right) \left(\frac{1}{x^2}\right) dx$

27 $\int \sin(7x - 3) dx$

28 $\int \frac{\sin(2\theta - 1)}{\cos(2\theta - 1) + 3} d\theta$

29 $\int \sec^2(5\theta - 2) d\theta$

30 $\int \cos(\pi x + 3) dx$

31 $\int \sec 2t \tan 2t dt$

32 $\int x e^{x^2 + 1} dx$

33 $\int \sqrt{t} e^{2t\sqrt{t}} dt$

34 $\int \frac{2}{\theta} (\ln \theta)^2 d\theta$

35 $\int \frac{dz}{z \ln 2z}$

36 $\int t \sqrt{3 - 5t^2} dt$

37 $\int \theta^2 \sec^2 \theta^3 d\theta$

38 $\int \frac{\sin \sqrt{t}}{2\sqrt{t}} dt$

39 $\int \tan^5 2t \sec^2 2t dt$

40 $\int \frac{dx}{\sqrt{x}(\sqrt{x} + 2)}$

41 $\int \sec^5 2t \tan 2t dt$

42 $\int \frac{x+3}{x^2+6x+7} dx$

43 $\int \frac{k^3 x^3}{\sqrt{a^2 - a^4 x^4}} dx$

44 $\int 3x\sqrt{x-1} dx$

45 $\int \csc^2 \pi t dt$

46 $\int \sqrt{1 + \cos \theta} \sin \theta d\theta$

47 $\int t^2 \sqrt{1-t} dt$

48 $\int \frac{r^2-1}{\sqrt{2r-1}} dr$

49 $\int \frac{e^{x^2} - e^{-x^2}}{e^{x^2} + e^{-x^2}} x dx$

50 $\int \frac{t^2+2}{\sqrt{t-5}} dt$

16.2

Methods of integration: integration by parts

As far as this point, you will have noticed that while differentiation and integration are so strongly linked, finding derivatives is greatly different from finding integrals. With the derivative rules available, you are able to find the derivative of about any function you can think of. By contrast, you can compute anti-derivatives for a rather small number of functions. Thus far, we have developed a set of basic integration formulae, most of which followed directly from the related differentiation formulae that you saw in Table 16.2.

Using substitution, in some cases, helps us reduce the difficulty of evaluating some integrals by rendering them in familiar forms. However, there are far too many cases, where the simple substitution will not help. For example,

$$\int x \cos x dx$$

cannot be evaluated by the methods you have learned so far. We improve the situation in this section by introducing a powerful and yet simple tool called *integration by parts*.

Recall the product rule for differentiation:

$$\frac{d}{dx}(u(x)v(x)) = u'(x)v(x) + u(x)v'(x),$$

which gives rise to the differential form

$$d(u(x)v(x)) = v(x)d(u(x)) + u(x)d(v(x)), \text{ and for convenience, we will write}$$

$$d(uv) = vdu + u dv.$$

If we integrate both sides of this equation, we get

$$\int d(uv) = \int vdu + \int u dv \Leftrightarrow uv = \int vdu + \int u dv.$$

Solving this equation for $u dv$, we get

$$\int u dv = uv - \int vdu.$$

This rule is the **integration by parts**.

The significance of this rule is not immediately apparent. We will see its great utility in a few examples.

Brook Taylor (1685–1731) is credited with devising integration by parts. Taylor is mostly known for his contributions to power series where his 'Taylor theorem' has several very important applications in mathematics and science.



Example 7

Evaluate $\int x \cos x \, dx$.

Solution

First, observe that you cannot evaluate this as it stands, i.e. it is not one of our basic integrals and no substitution can help either.

Notice how you need to make a clever choice of u and dv so that the integral on the right side is one that will ease your work ahead. We need to choose u (to differentiate) and dv (to integrate); thus we let

$$u = x, \text{ and } dv = \cos x \, dx.$$

Then $du = dx$, and $v = \sin x$. (We will introduce c at the end of the process.)

It is usually helpful to organize your work in a table form:

$$\begin{array}{ll} u = x & du = dx \\ dv = \cos x \, dx & v = \sin x \end{array}$$

This gives us:

$$\begin{aligned} \int \underbrace{x}_u \underbrace{\cos x \, dx}_{dv} &= \int u \, dv = uv - \int v \, du \\ &= x \sin x - \int \sin x \, dx \\ &= x \sin x + \cos x + c \end{aligned}$$

To verify your result, simply differentiate the right-hand side.

$$\frac{d}{dx}(x \sin x + \cos x + c) = \sin x + x \cos x - \sin x + 0 = x \cos x$$



Note: What other choices can you make?

There are three other choices of u and dv in this problem:

1 If we let

$$\left. \begin{array}{ll} u = \cos x & du = -\sin x \, dx \\ dv = dx & v = \frac{x^2}{2} \end{array} \right\} \Rightarrow \int x \cos x \, dx = \frac{x^2}{2} \cos x + \int \frac{x^2}{2} \sin x \, dx$$

This new integral is worse than the one we started with!

2 If we let

$$\left. \begin{array}{ll} u = x \cos x & du = (\cos x - x \sin x) \, dx \\ dv = x \, dx & v = x \end{array} \right\} \Rightarrow \int x \cos x \, dx = x^2 \cos x - \int x(\cos x - x \sin x) \, dx$$

Again, this new integral is worse than the one we started with!

3 If we let

$$\begin{array}{ll} u = 1 & du = 0 \\ dv = x \cos x \, dx & v = ?? \end{array}$$

This is obviously a bad choice since we still do not know how to integrate $dv = x \cos x \, dx$.

The objective of integration by parts is to move from an integral $\int u dv$ (which we cannot see how to evaluate) to an integral $\int v du$ which we *can* integrate. So, keep in mind that integration by parts does not necessarily work all the time, and that we have to develop enough experience with such a process in order to make the 'correct' choice for u and $v du$.

Example 8

Evaluate $\int x e^{-x} dx$.

Solution

We let

$$\left. \begin{array}{l} u = x \quad du = dx \\ dv = e^{-x} dx \quad v = -e^{-x} \end{array} \right\} \Rightarrow \int x e^{-x} dx = -x e^{-x} + \int e^{-x} dx \\ = -x e^{-x} - e^{-x} + c$$

Example 9

Evaluate $\int \ln x dx$.

Solution

$$\left. \begin{array}{l} u = \ln x \quad du = \frac{dx}{x} \\ dv = dx \quad v = x \end{array} \right\} \Rightarrow \int \ln x dx = x \ln x - \int x \frac{dx}{x} \\ = x \ln x - x + c$$

Example 10

Evaluate $\int x^2 \ln x dx$.

Solution

Since x^2 is easier to integrate than $\ln x$, and the derivative of $\ln x$ is also easier than $\ln x$ itself, we make the following substitution:

$$\left. \begin{array}{l} u = \ln x \quad du = \frac{dx}{x} \\ dv = x^2 dx \quad v = \frac{x^3}{3} \end{array} \right\} \Rightarrow \int x^2 \ln x dx = \frac{x^3}{3} \ln x - \int \frac{x^3}{3} \frac{dx}{x} \\ = \frac{x^3}{3} \ln x - \int \frac{1}{3} x^2 dx \\ = \frac{x^3}{3} \ln x - \frac{1}{9} x^3 + c$$

Example 11 – Repeated use of integration by parts

Evaluate $\int x^2 \sin x dx$.

Solution

Since $\sin x$ is equally easy to integrate or differentiate while x^2 is easier to differentiate, we make the following substitution:

$$\left. \begin{array}{l} u = x^2 \quad du = 2x dx \\ dv = \sin x dx \quad v = -\cos x \end{array} \right\} \Rightarrow \int x^2 \sin x dx = -x^2 \cos x + 2 \int x \cos x dx$$

This first step simplified the original integral. However, the right-hand side still needs further integration. Here again, we use integration by parts.

$$\left. \begin{array}{l} u = x^2 \quad du = 2x \, dx \\ dv = \cos x \, dx \quad v = \sin x \end{array} \right\} \Rightarrow \int 2x \cos x \, dx = 2x \sin x - 2 \int \sin x \, dx \\ = 2x \sin x + 2 \cos x + c$$

Combining the two results, we can now write

$$\begin{aligned} \int x^2 \sin x \, dx &= -x^2 \cos x + 2 \int x \cos x \, dx \\ &= x^2 \cos x + 2x \sin x + 2 \cos x + c. \end{aligned}$$



Note: When making repeated applications of the integration by parts, you need to be careful not to change the 'nature' of the substitution in successive applications. For instance, in the previous example, the first substitution was $u = x^2$ and $dv = \sin x \, dx$. If in the second step, you had switched the substitution to $u = \cos x$ and $dv = 2x \, dx$, you would have obtained

$$\begin{aligned} \int x^2 \sin x \, dx &= -x^2 \cos x + x^2 \cos x + \int x^2 \sin x \, dx \\ &= \int x^2 \sin x \, dx, \end{aligned}$$

thus 'undoing' the previous integration and returning to the original integral.

Example 12

Evaluate $\int x^2 e^x \, dx$.

Solution

Since e^x is equally easy to integrate or differentiate while x^2 is easier to differentiate, we make the following substitution:

$$\left. \begin{array}{l} u = x^2 \quad du = 2x \, dx \\ dv = e^x \, dx \quad v = e^x \end{array} \right\} \Rightarrow \int x^2 e^x \, dx = x^2 e^x - 2 \int x e^x \, dx$$

This first step simplified the original integral. However, the right-hand side still needs further integration. Here again, we use integration by parts.

$$\left. \begin{array}{l} u = 2x \quad du = 2 \, dx \\ dv = e^x \, dx \quad v = e^x \end{array} \right\} \Rightarrow \int 2x e^x \, dx = 2x e^x - 2 \int e^x \, dx \\ = 2x e^x - 2e^x + c$$

Hence,

$$\begin{aligned} \int x^2 e^x \, dx &= x^2 e^x - \int 2x e^x \, dx \\ &= x^2 e^x - 2x e^x + 2e^x + c. \end{aligned}$$

Using integration by parts to find unknown integrals

Integrals like the one in the next example occur frequently in electricity problems. Their evaluation requires repeated applications of integration by parts followed by algebraic manipulation.

Example 13

Evaluate $\int \cos x e^x dx$.

Solution

Let

$$\left. \begin{array}{l} u = e^x \quad du = e^x dx \\ dv = \cos x dx \quad v = \sin x \end{array} \right\} \Rightarrow \int \cos x e^x dx = e^x \sin x - \int \sin x e^x dx$$

The second integral is of the same nature, so we use integration by parts again.

$$\left. \begin{array}{l} u = e^x \quad du = e^x dx \\ dv = \sin x dx \quad v = -\cos x \end{array} \right\} \Rightarrow \int \sin x e^x dx = -e^x \cos x + \int \cos x e^x dx$$

Hence,

$$\begin{aligned} \int \cos x e^x dx &= e^x \sin x - \int \sin x e^x dx \\ &= e^x \sin x - (-e^x \cos x + \int \cos x e^x dx) \\ &= e^x \sin x + e^x \cos x - \int \cos x e^x dx. \end{aligned}$$

Now, the unknown integral appears on both sides of the equation, thus

$$\begin{aligned} \int \cos x e^x dx + \int \cos x e^x dx &= e^x \sin x + e^x \cos x \\ \Rightarrow 2 \int \cos x e^x dx &= e^x \sin x + e^x \cos x \\ \Rightarrow \int \cos x e^x dx &= \frac{e^x \sin x + e^x \cos x}{2} + c. \end{aligned}$$

Example 14

Evaluate $\int x \ln x dx$.

Solution

$$\left. \begin{array}{l} u = \ln x \quad du = \frac{dx}{x} \\ dv = x dx \quad v = \frac{x^2}{2} \end{array} \right\} \Rightarrow \int x^2 \ln x dx = \frac{x^2}{2} \ln x - \int \frac{x^2}{2} \frac{dx}{x}$$
$$= \frac{x^2}{2} \ln x - \int \frac{x dx}{2} = \frac{x^2}{2} \ln x - \frac{x^2}{4} + c$$

Alternatively, we could have used a different substitution:

$$\left. \begin{array}{l} u = x \ln x \quad du = (\ln x + 1) dx \\ dv = dx \quad v = x \end{array} \right\} \Rightarrow \int x \ln x dx = x^2 \ln x - \int x (\ln x + 1) dx$$
$$= x^2 \ln x - \int x \ln x dx - \int x dx$$

Adding $\int x \ln x \, dx$ to both sides and integrating $\int x \, dx$ we get

$$\int x \ln x \, dx + \int x \ln x \, dx = x^2 \ln x - \frac{x^2}{2} + c$$

$$\Rightarrow 2 \int x \ln x \, dx = x^2 \ln x - \frac{x^2}{2} + c$$

$$\Rightarrow \int x \ln x \, dx = \frac{1}{2} \left(x^2 \ln x - \frac{x^2}{2} + c \right) = \frac{x^2 \ln x}{2} - \frac{x^2}{4} + C.$$

Note: The constant c is arbitrary, and hence it is unimportant that we use $c/2$ or C in our final answer.

Exercise 16.2

In questions 1–22, evaluate each integral.

1 $\int x^2 e^{-x^3} \, dx$

2 $\int x^2 e^{-x} \, dx$

3 $\int x^2 \cos 3x \, dx$

4 $\int x^2 \sin ax \, dx$

5 $\int \cos x \ln(\sin x) \, dx$

6 $\int x \ln x^2 \, dx$

7 $\int x^2 \ln x \, dx$

8 $\int x^2(e^x - 1) \, dx$

9 $\int x \cos \pi x \, dx$

10 $\int e^{3t} \cos 2t \, dt$

11 $\int \arcsin x \, dx$

12 $\int x^3 e^x \, dx$

13 $\int e^{-2x} \sin 2x \, dx$

14 $\int \sin(\ln x) \, dx$

15 $\int \cos(\ln x) \, dx$

16 $\int \ln(x + x^2) \, dx$

17 $\int e^{tx} \sin x \, dx$

18 $\int x \sec^2 x \, dx$

19 $\int \sin x \sin 2x \, dx$

20 $\int x \arctan x \, dx$

21 $\int \frac{\ln x}{\sqrt{x}} \, dx$

22 $\int t \sec^2 t \, dt$

23 In one scene of the movie *Stand and Deliver*, the teacher shows his students how to evaluate $\int x^2 \sin x \, dx$ by setting up a chart similar to the following.

	$\sin x$	
x^2	$-\cos x$	$+$
$2x$	$-\sin x$	$-$
2	$\cos x$	$+$

Multiply across each row and add the result. The integral is

$$\int x^2 \sin x \, dx = -x^2 \cos x + 2x \sin x + 2 \cos x + c.$$

Explain why the method works for this problem.

In questions 24–26, use the result of question 23 to evaluate each integral.

24 $\int x^4 \sin x \, dx$

25 $\int x^5 \cos x \, dx$

26 $\int x^4 e^x \, dx$

27 Show that the method used in question 23 will not work with

$$\int x^2 \ln x \, dx.$$

28 Show that $\int x^n e^x dx = x^n e^x - n \int x^{n-1} e^x dx$, then use this *reduction formula* to show that $\int x^4 e^x dx = ax^4 e^x + bx^3 e^x + cx^2 e^x + dx e^x + fe^x + g$, where a, b, c, \dots, g are to be determined.

29 Show that $\int x^n \ln x \, dx = \frac{x^{n+1}}{n+1} \ln x - \frac{x^{n+1}}{(n+1)^2} + c$.

30 Show that $\int e^{mx} \cos nx \, dx = \frac{e^{mx}(m \cos nx + n \sin nx)}{m^2 + n^2} + c$.

31 Show that $\int e^{mx} \sin nx \, dx = \frac{e^{mx}(m \sin nx - n \cos nx)}{m^2 + n^2} + c$.

16.3 More methods of integration

In the previous section, we looked at a very powerful method for integration that has a wide range of applications. However, integration by parts does not work for all situations, and in some cases where it works, it may not be the most efficient of methods. We learned about substitution before. In this section we will consider a few trigonometric integrals and some substitutions related to trigonometric functions or their inverses.

This section is basically a set of examples that will show you how to deal with a variety of cases.

Some of the trigonometric identities you learned before will prove very helpful in this section. Key identities we will make use of are the following:

1 $\cos^2 \theta + \sin^2 \theta = 1$

2 $\sin^2 \theta = \frac{1 - \cos 2\theta}{2}$

3 $\cos^2 \theta = \frac{1 + \cos 2\theta}{2}$

4 $\sec^2 \theta = 1 + \tan^2 \theta$

Example 15

Evaluate $\int \sin^2 x \, dx$.

Solution

We can use identity (2) from the list above.

$$\begin{aligned} \int \sin^2 x \, dx &= \int \frac{1 - \cos 2x}{2} \, dx = \frac{1}{2} \int (1 - \cos 2x) \, dx \\ &= \frac{1}{2} \left(x - \frac{1}{2} \sin 2x \right) + c \end{aligned}$$

Example 16

Evaluate $\int \cos^4 \theta d\theta$.

Solution

Identity (3) will give us the following:

$$\begin{aligned} \int \cos^4 \theta d\theta &= \int \left(\frac{1 + \cos 2\theta}{2} \right)^2 d\theta = \frac{1}{4} \int (1 + 2 \cos 2\theta + \cos^2 2\theta) d\theta \\ &= \frac{1}{4} \int \left(1 + 2 \cos 2\theta + \frac{1 + \cos 4\theta}{2} \right) d\theta \\ &= \frac{1}{8} \left(2\theta + 2 \sin 2\theta + \theta + \frac{1}{4} \sin 4\theta \right) + c \\ &= \frac{1}{32} (12\theta + 8 \sin 2\theta + \sin 4\theta) + c \end{aligned}$$

Here is a list of a few cases and how to find the integral. There are a few more integrals that we did not list here. On exams, any non-standard cases will be accompanied by a recommended substitution.

Integral	How to find it
$\int \sin^m x \cos^n x dx$	If m is odd, then break $\sin^m x$ into $\sin x$ and $\sin^{m-1} x$, use the substitution $u = \cos x$ and change the integral into the form $\int \cos^p x \sin x dx = \int u^p du$. Similarly if n is odd.
$\int \tan^m x \sec^n x dx$	If m and n are odd, break off a term for $\sec x \tan x dx$ and express the integrand in terms of $\sec x$ since $d(\sec x) = \sec x \tan x dx$.
$\int \tan^n x dx$	Write the integrand as $\int \tan^{n-2} x \tan^2 x dx$, replace $\tan^2 x$ with $\sec^2 x - 1$ and then use $u = \tan x$.
$\int \sec^n x dx$	If n is even, factor a $\sec^2 x$ out and write the rest in terms of $\tan^2 x + 1$. If n is odd, factor a $\sec^3 x$ out. Here, integration by parts may be useful.

Example 17

Evaluate $\int \sec x dx$.

Solution

This integral is evaluated using a 'clever' multiplication by an atypical factor, then:

$$\int \sec x dx = \int \sec x \frac{\tan x + \sec x}{\tan x + \sec x} dx = \int \frac{\sec x \tan x + \sec^2 x}{\tan x + \sec x} dx$$

Now use the substitution $u = \sec x + \tan x \Rightarrow du = (\sec x \tan x + \sec^2 x) dx$; hence,

$$\begin{aligned} \int \sec x dx &= \int \frac{\sec x \tan x + \sec^2 x}{\tan x + \sec x} dx = \int \frac{du}{u} \\ &= \ln|u| + c = \ln|\tan x + \sec x| + c. \end{aligned}$$

Example 18

Evaluate $\int \sec^3 x \, dx$.

Solution

This can be evaluated using integration by parts and some of the results we have already established.

$$\begin{aligned}u &= \sec x & du &= \sec x \tan x \, dx \\dv &= \sec^2 x \, dx & v &= \tan x\end{aligned}$$

Hence,

$$\begin{aligned}\int \sec^3 x \, dx &= \sec x \tan x - \int \tan x \sec x \tan x \, dx \\&= \sec x \tan x - \int \sec x \tan^2 x \, dx \\&= \sec x \tan x - \int \sec x [\sec^2 x - 1] \, dx \\&= \sec x \tan x - \int \sec^3 x \, dx + \int \sec x \, dx.\end{aligned}$$

Adding $\int \sec^3 x \, dx$ to both sides:

$$\begin{aligned}2 \int \sec^3 x \, dx &= \sec x \tan x + \int \sec x \, dx \\&= \sec x \tan x + \ln|\sec x + \tan x|\end{aligned}$$

And finally,

$$\int \sec^3 x \, dx = \frac{\sec x \tan x + \ln|\sec x + \tan x|}{2} + c.$$

Example 19

Evaluate $\int \sin^3 x \cos^3 x \, dx$.

Solution

This integral can be evaluated by separating either a cosine or a sine, then writing the rest of the expression in terms of sine or cosine.

We will separate a cosine here.

$$\begin{aligned}\int \sin^3 x \cos^3 x \, dx &= \int \sin^3 x \cos^2 x \cos x \, dx \\&= \int \sin^3 x (1 - \sin^2 x) \cos x \, dx \\&= \int (\sin^3 x - \sin^5 x) \cos x \, dx\end{aligned}$$

Now we let

$$\begin{aligned}u &= \sin x \Rightarrow du = \cos x \, dx, \text{ and hence} \\ \int \sin^3 x \cos^3 x \, dx &= \int (\sin^3 x - \sin^5 x) \cos x \, dx \\&= \int (u^3 - u^5) du = \frac{u^4}{4} - \frac{u^6}{6} + c \\&= \frac{\sin^4 x}{4} - \frac{\sin^6 x}{6} + c.\end{aligned}$$

Some useful trigonometric substitutions

Evaluating integrals that involve $(a^2 - u^2)$, $(a^2 + u^2)$ or $(u^2 - a^2)$ may be rendered simpler by using some trigonometric substitution like the ones listed below.

Expression	Substitution	Simplified	du
$a^2 - u^2$	$u = a \sin \theta$	$a^2 - u^2 = a^2 - a^2 \sin^2 \theta$ $= a^2(1 - \sin^2 \theta) = a^2 \cos^2 \theta$	$a \cos \theta d\theta$
$a^2 + u^2$	$u = a \tan \theta$	$a^2 + u^2 = a^2 + a^2 \tan^2 \theta$ $= a^2(1 + \tan^2 \theta) = a^2 \sec^2 \theta$	$a \sec^2 \theta d\theta$
$u^2 - a^2$	$u = a \sec \theta$	$u^2 - a^2 = a^2 \sec^2 \theta - a^2$ $= a^2(\sec^2 \theta - 1) = a^2 \tan^2 \theta$	$a \sec \theta \tan \theta d\theta$

As you notice, this substitution is not the usual form. For convenience, we express the variable of integration in terms of the new variable. For example, rather than saying let $\theta = \arcsin \frac{u}{a}$, we say $u = a \sin \theta$. This allows us to easily find an expression for du . We will clarify the use of this type of substitution with a few examples. One important aspect of the process is how to revert back to the variable of integration. We will demonstrate that in the following examples.

Example 20

Evaluate $\int \frac{dx}{\sqrt{a^2 - x^2}}$.

Solution

This integrand is of the form involving $a^2 - u^2$, where $u = x$. We use the substitution $x = a \sin \theta$.

$$\Rightarrow dx = a \cos \theta d\theta,$$

$$\sqrt{a^2 - x^2} = \sqrt{a^2 \cos^2 \theta} = a \cos \theta$$

Hence,

$$\int \frac{dx}{\sqrt{a^2 - x^2}} = \int \frac{a \cos \theta d\theta}{a \cos \theta} = \int d\theta = \theta + c.$$

Now, consider the right triangle where

$$x = a \sin \theta \Leftrightarrow \sin \theta = \frac{x}{a}.$$

$$\int \frac{dx}{\sqrt{a^2 - x^2}} = \theta + c = \arcsin \frac{x}{a} + c.$$

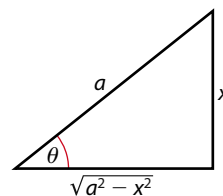

Example 21

Evaluate $\int \frac{dt}{\sqrt{a^2 - t^2}}$.

Solution

This integrand is of the form involving $a^2 - u^2$, where $u = t$. We use the substitution $t = a \sin \theta$.

$$\Rightarrow dt = a \cos \theta d\theta,$$

$$a^2 - t^2 = a^2 \cos^2 \theta$$

And so

$$\int \frac{dt}{a^2 - t^2} = \int \frac{a \cos \theta d\theta}{a^2 \cos^2 \theta} = \frac{1}{a} \int \sec \theta d\theta = \frac{1}{a} \ln |\sec \theta + \tan \theta| + c.$$

Now, in the triangle right,

$$t = a \sin \theta \Leftrightarrow \sin \theta = \frac{t}{a}$$

$$\cos \theta = \frac{\sqrt{a^2 - t^2}}{a};$$

$$\tan \theta = \frac{t}{\sqrt{a^2 - t^2}}; \sec \theta = \frac{a}{\sqrt{a^2 - t^2}}$$

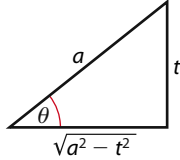

Consequently,

$$\int \frac{dt}{a^2 - t^2} = \frac{1}{a} \ln |\sec \theta + \tan \theta| + c = \frac{1}{a} \ln \left| \frac{a}{\sqrt{a^2 - t^2}} + \frac{t}{\sqrt{a^2 - t^2}} \right| + c$$

$$= \frac{1}{a} \ln \left| \frac{a + t}{\sqrt{a^2 - t^2}} \right| + c.$$

This is an acceptable answer. However, using the logarithmic properties you learned in Chapter 5, you can simplify further.

$$\int \frac{dt}{a^2 - t^2} = \frac{1}{a} \ln \left| \frac{a + t}{\sqrt{a^2 - t^2}} \right| + c = \frac{1}{a} \ln \sqrt{\frac{(a + t)^2}{a^2 - t^2}} + c$$

$$= \frac{1}{a} \ln \sqrt{\frac{(a + t)^2}{(a - t)(a + t)}} + c = \frac{1}{a} \ln \sqrt{\frac{(a + t)}{(a - t)}} + c$$

$$= \frac{1}{2a} \ln \left| \frac{(a + t)}{(a - t)} \right| + c$$

Example 22

Evaluate $\int \frac{dt}{a^2 + t^2}$.

Solution

This integrand is of the form involving $a^2 + u^2$, where $u = t$.

We use the substitution $t = a \tan \theta$.

$$\Rightarrow dt = a \sec^2 \theta d\theta,$$

$$a^2 + t^2 = a^2(1 + \tan^2 \theta) = a^2 \sec^2 \theta$$

And so

$$\int \frac{dt}{a^2 + t^2} = \int \frac{a \sec^2 \theta d\theta}{a^2 \sec^2 \theta} = \frac{1}{a} \int d\theta = \frac{1}{a} \theta + c.$$

Since $t = a \tan \theta$, then $\tan \theta = \frac{t}{a} \Rightarrow \theta = \arctan \frac{t}{a}$.

Consequently,

$$\int \frac{dt}{a^2 + t^2} = \frac{1}{a} \theta + c = \frac{1}{a} \arctan \frac{t}{a} + c.$$

Example 23

Evaluate $\int \sqrt{x^2 + 5} \, dx$.

Solution

This integrand is of the form involving $a^2 + u^2$, where $u = x$. We use the substitution $x = a \tan \theta = \sqrt{5} \tan \theta$.

$$\Rightarrow dx = \sqrt{5} \sec^2 \theta d\theta,$$

$$5 + x^2 = 5(1 + \tan^2 \theta) = 5 \sec^2 \theta d\theta$$

And so

$$\begin{aligned} \int \sqrt{x^2 + 5} \, dx &= \int \sqrt{5 \sec^2 \theta} \sqrt{5} \sec^2 \theta d\theta \\ &= \int 5 \sec^3 \theta d\theta. \end{aligned}$$

Now, earlier in Example 18, we have seen that

$$\int \sec^3 x \, dx = \frac{\sec x \tan x + \ln|\sec x + \tan x|}{2} + c.$$

And therefore

$$\int \sqrt{x^2 + 5} \, dx = 5 \int \sec^3 \theta d\theta = 5 \left(\frac{\sec \theta \tan \theta + \ln|\sec \theta + \tan \theta|}{2} \right) + c.$$

Now, in the triangle right,

$$\tan \theta = \frac{x}{\sqrt{5}},$$

$$\sec \theta = \frac{\sqrt{5 + x^2}}{\sqrt{5}} = \sqrt{\frac{5 + x^2}{5}}, \text{ and so}$$

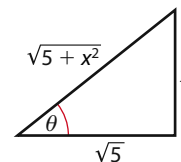

$$\int \sqrt{x^2 + 5} \, dx = 5 \left(\frac{\sec \theta \tan \theta + \ln|\sec \theta + \tan \theta|}{2} \right) + c$$

$$= 5 \left(\frac{\left(\sqrt{\frac{5 + x^2}{5}} \cdot \frac{x}{\sqrt{5}} + \ln \left| \sqrt{\frac{5 + x^2}{5}} + \frac{x}{\sqrt{5}} \right| \right)}{2} \right) + c$$

$$= \frac{\sqrt{5}}{2} (\sqrt{5 + x^2} \cdot x) + \frac{1}{2} \ln \left(\frac{\sqrt{5 + x^2} + x}{\sqrt{5}} \right) + c$$

$$= \frac{\sqrt{5}}{2} (\sqrt{5 + x^2} \cdot x) + \frac{1}{2} (\ln(\sqrt{5 + x^2} + x) - \ln \sqrt{5}) + c$$

$$= \frac{\sqrt{5}}{2} (x \sqrt{5 + x^2}) + \frac{1}{2} (\ln(\sqrt{5 + x^2} + x)) + C.$$

In the last step we set $-\frac{1}{2} \ln \sqrt{5} + c = C$.

Example 24

Evaluate $\int \sqrt{25 - 4x^2} dx$.

Solution

This integrand is of the form involving $a^2 - u^2$, where $u = 2x$. We use the substitution $2x = 5 \sin \theta$.

$$2dx = 5 \cos \theta d\theta \Rightarrow dx = \frac{5}{2} \cos \theta d\theta$$

$$\sqrt{25 - 4x^2} = \sqrt{25 - 25 \sin^2 \theta} = 5 \cos \theta$$

And so

$$\begin{aligned} \int \sqrt{25 - 4x^2} dx &= \int 5 \cos \theta \left(\frac{5}{2} \cos \theta d\theta \right) = \frac{25}{2} \int \cos^2 \theta d\theta \\ &= \frac{25}{2} \int \left(\frac{1 + \cos 2\theta}{2} \right) d\theta = \frac{25}{2} \left(\frac{\theta}{2} + \frac{1}{4} \sin 2\theta \right) + c \\ &= \frac{25}{8} (2\theta + \sin 2\theta) + c. \end{aligned}$$

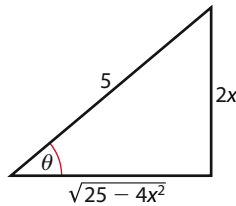

But, since $2x = 5 \sin \theta$, then $\sin \theta = \frac{2x}{5} \Rightarrow \theta = \arcsin \frac{2x}{5}$, and since $\sin 2\theta = 2 \sin \theta \cos \theta$, then

$$\begin{aligned} \int \sqrt{25 - 4x^2} dx &= \frac{25}{8} (2\theta + \sin 2\theta) + c \\ &= \frac{25}{8} \left(2 \arcsin \frac{2x}{5} + 2 \left(\frac{2x}{5} \right) \left(\frac{\sqrt{25 - 4x^2}}{5} \right) \right) + c \\ &= \frac{25}{4} \arcsin \frac{2x}{5} + \frac{x\sqrt{25 - 4x^2}}{2} + c. \end{aligned}$$

Exercise 16.3

In questions 1–44, evaluate each integral.

1 $\int \sin^3 t \cos^2 t dt$

2 $\int \sin^3 t \cos^3 t dt$

3 $\int \sin^3 3\theta \cos 3\theta d\theta$

4 $\int \frac{1}{t^2} \sin^5 \left(\frac{1}{t} \right) \cos^2 \left(\frac{1}{t} \right) dt$

5 $\int \frac{\sin^3 x}{\cos^2 x} dx$

6 $\int \tan^5 3x \sec^2 3x dx$

7 $\int \theta \tan^3 \theta^2 \sec^4 \theta^2 d\theta$

8 $\int \frac{1}{\sqrt{t}} \tan^3 \sqrt{t} \sec^3 \sqrt{t} dt$

9 $\int \tan^4(5t) dt$

10 $\int \frac{dt}{1 + \sin t}$

• **Hint:** multiply the integrand by $\frac{1 - \sin t}{1 - \sin t}$.

11 $\int \frac{d\theta}{1 + \cos \theta}$

13 $\int \frac{\sin x - 5 \cos x}{\sin x + \cos x} dx$

14 $\int \frac{\sec \theta \tan \theta}{1 + \sec^2 \theta} d\theta$

16 $\int \frac{1}{(1 + t^2) \arctan t} dt$

18 $\int \sin^3 x dx$

20 $\int \frac{\sin^3 \sqrt{x}}{\sqrt{x}} dx$

22 $\int \frac{\cos \theta + \sin 2\theta}{\sin \theta} d\theta$

24 $\int \frac{\cos x}{2 - \sin x} dx$

26 $\int \frac{\sec(\sqrt{t})}{\sqrt{t}} dt$

28 $\int \sqrt{1 - 9x^2} dx$

30 $\int \sqrt{4 + t^2} dt$

32 $\int \frac{1}{\sqrt{9 - 4x^2}} dx$

34 $\int \frac{\cos x}{\sqrt{1 + \sin^2 x}} dx$

36 $\int \frac{x}{x^2 + 16} dx$

38 $\int \frac{dx}{(9 - x^2)^{\frac{3}{2}}}$

40 $\int e^{2x} \sqrt{1 + e^{2x}} dx$

42 $\int \frac{e^x dx}{\sqrt{e^{2x} + 9}}$

44 $\int \frac{x^3}{(x + 2)^2} dx$

45 The integral $\int \frac{x}{x^2 + 9} dx$ can be evaluated either by trigonometric substitution or by direct substitution. Do it both ways and reconcile the results.

46 The integral $\int \frac{x^2}{x^2 + 9} dx$ can be evaluated either by trigonometric substitution or by rewriting the numerator as $(x^2 + 9) - 9$. Do it both ways and reconcile the results.

12 $\int \frac{1 + \sin t}{\cos t} dt$

• **Hint:** find numbers a and b such that $\sin x - 5 \cos x = a(\sin x + \cos x) + b(\cos x - \sin x)$.

15 $\int \frac{\arctan t}{1 + t^2} dt$

17 $\int \frac{dx}{x\sqrt{1 - (\ln x)^2}}$

19 $\int \frac{\sin^3 x}{\sqrt{\cos x}} dx$

21 $\int \cos t \cos^3(\sin t) dt$

23 $\int t \sec t \tan t dt$

25 $\int e^{-2x} \tan(e^{-2x}) dx$

27 $\int \frac{dt}{1 + \cos 2t}$

29 $\int \frac{dx}{(x^2 + 4)^{\frac{3}{2}}}$

31 $\int \frac{3e^t dt}{4 + e^{2t}}$

33 $\int \frac{1}{\sqrt{4 + 9x^2}} dx$

35 $\int \frac{x}{\sqrt{4 - x^2}} dx$

37 $\int \frac{\sqrt{4 - x^2}}{x^2} dx$

39 $\int x\sqrt{1 + x^2} dx$

41 $\int e^x \sqrt{1 - e^{2x}} dx$

43 $\int \frac{\ln x}{\sqrt{x}} dx$

16.4 Area and definite integral

The main goal of this section is to introduce you to the following major problem of calculus.

The area problem: Given a function $f(x)$ that is continuous and non-negative on an interval $[a, b]$, find the area between the graph of $f(x)$ and the interval $[a, b]$ on the x -axis.

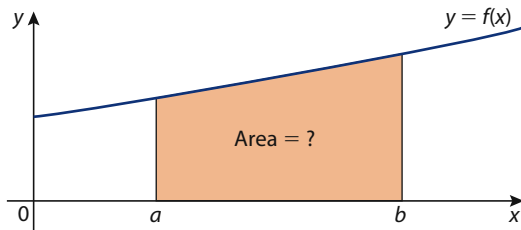

We divide the base interval $[a, b]$ into n equal sub-intervals, and over each sub-interval construct a rectangle that extends from the x -axis to any point on the curve $y = f(x)$ that is above the sub-interval. The particular point does not matter – it can be above the centre, above one endpoint, or any other point in the sub-interval. In Figure 16.1 it is above the centre.

For each n , the total area of the rectangles can be viewed as an approximation to the exact area in question. Moreover, it is evident intuitively that as n increases, these approximations will get better and better and will eventually approach the exact area as a limit. See Figure 16.2.

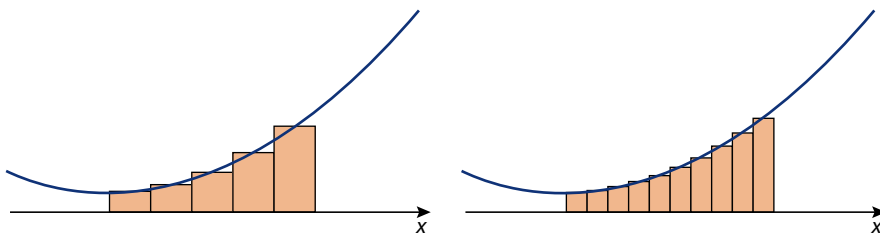

A traditional approach to this would be to study how the choice of where to erect the rectangular strip does not affect the approximation as the number of intervals increases. You can construct ‘inscribed’ rectangles, which, at the start, give you an underestimate of the area. On the other hand, you can construct ‘circumscribed’ rectangles that, at the start, overestimate the area. See Figure 16.3.

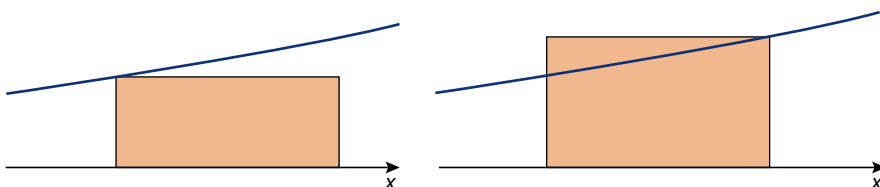

● **Hint:** This is only an expository treatment that explains to you how the definite integral is developed. You will not be required to reproduce this calculation yourself.

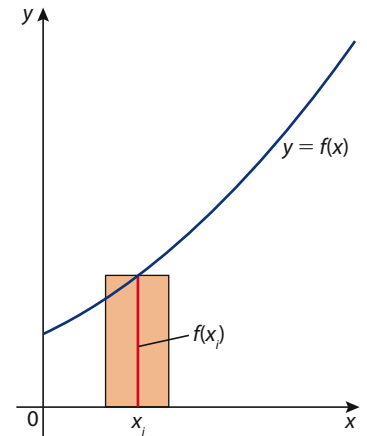

Figure 16.1

Figure 16.2

Figure 16.3

Figure 16.4

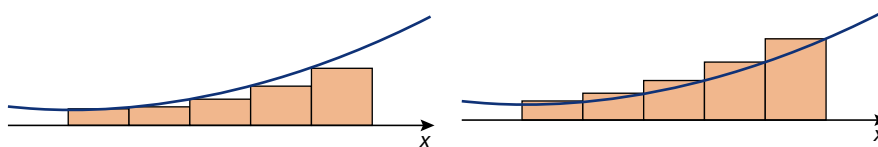

Figure 16.4 above shows n inscribed and subscribed rectangles and Figure 16.5 shows us the difference between the overestimates and the underestimates.

Figure 16.5

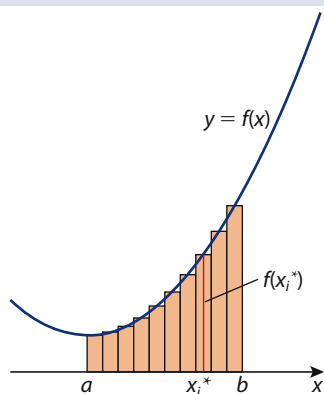

Figure 16.6

Figure 16.5 demonstrates that as the number n increases, the difference between the estimates will approach 0. Since, in Figure 16.1, we set up our rectangles by choosing a point inside the interval, the areas of the rectangles will lie between the overestimates and the underestimates, and hence as the difference between the extremes approaches zero, the rectangles we constructed will give the area of the region required.

If we consider the width of each interval to be Δx , the area of any rectangle is given as

$$A_i = f(x_i^*)\Delta x.$$

The total area of the rectangles so constructed is

$$A_n = \sum_{t=0}^n f(x_t^*)\Delta x$$

where x_i^* is an arbitrary point within any sub-interval $[x_{i-1}, x_i]$, $x_0 = a$ and $x_n = b$.

In the case of a function $f(x)$ that has both positive and negative values on $[a, b]$, it is necessary to consider the *signs* of the areas in the following sense.

Figure 16.7

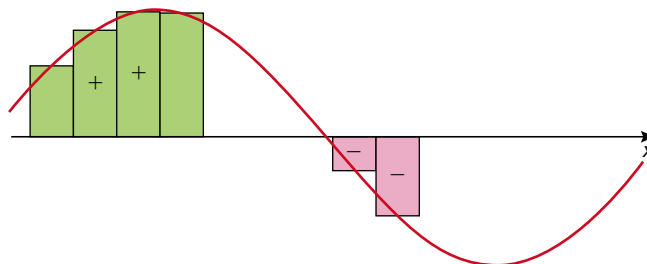

On each sub-interval, we have a rectangle with width Δx and height $f(x^*)$. If $f(x^*) > 0$, this rectangle is above the x -axis; if $f(x^*) < 0$, this rectangle is below the x -axis. We will consider the sum defined above as the sum of the signed areas of these rectangles. That means the total area on the interval is the sum of the areas above the x -axis minus the sum of the areas of the rectangles below the x -axis.

We are now ready to look at a 'loose' definition of the definite integral.

If $f(x)$ is a continuous function defined for $a \leq x \leq b$, we divide the interval $[a, b]$ into n sub-intervals of equal width $\Delta x = (b - a)/n$. We let $x_0 = a$ and $x_n = b$ and we choose $x_1^*, x_2^*, \dots, x_n^*$ in these sub-intervals, so that x_i^* lies in the i th sub-interval $[x_{i-1}, x_i]$. Then the definite integral of $f(x)$ from a to b is

$$\int_a^b f(x) dx = \lim_{n \rightarrow \infty} \sum_{i=1}^n f(x_i^*) \Delta x.$$

In the notation $\int_a^b f(x) dx$, in addition to the known integrand and differential, a and b are called the limits of integration: a is the lower limit and b is the upper limit.

Note: Because we have assumed that $f(x)$ is continuous, it can be proved that the limit definition above always exists and gives the same value no matter how we choose the points x_i^* . If we take these points at the centre, at two-thirds the distance from the lower endpoint or at the upper endpoint, the value is the same. This is why we will state the definition of the integral from now on as

$$\int_a^b f(x) dx = \lim_{n \rightarrow \infty} \sum_{i=1}^n f(x_i) \Delta x.$$

Calling the area under the function an integral is no coincidence. To make the point, let us take the following example.

Example 25(I)

Find the area, $A(x)$, between the graph of the function $f(x) = 3$ and the interval $[-1, x]$, and find the derivative $A'(x)$ of this area function.

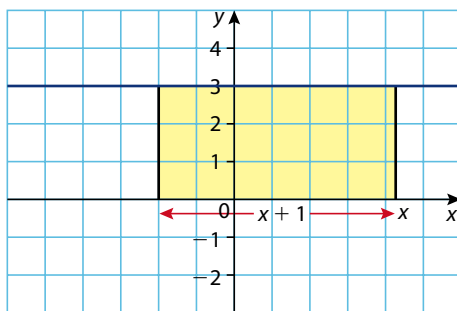

Solution

The area in question is

$$A(x) = 3(x - (-1)) = 3x + 3, \text{ and}$$

$$A'(x) = 3 = f(x).$$



For a list of recommended resources about definite integrals, visit www.pearsonhotlinks.com, enter the ISBN or title of this book and select weblink 2.

Example 25(II)

Find the area, $A(x)$, between the graph of the function $f(x) = 3x + 2$ and the interval $[-2/3, x]$, and find the derivative $A'(x)$ of this area function.

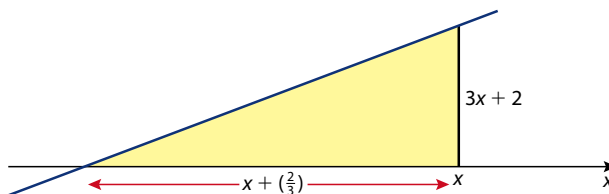
**Solution**

The area in question is

$$A(x) = \frac{1}{2} \left(x + \frac{2}{3} \right) (3x + 2) = \frac{1}{6} (3x + 2)^2, \text{ since this is the area of a triangle.}$$

$$\text{Hence, } A'(x) = \frac{1}{6} \times 2(3x + 2) \times 3 = 3x + 2 = f(x).$$

Example 25(III)

Find the area, $A(x)$, between the graph of the function $f(x) = x + 2$ and the interval $[-1, x]$, and find the derivative $A'(x)$ of this area function.

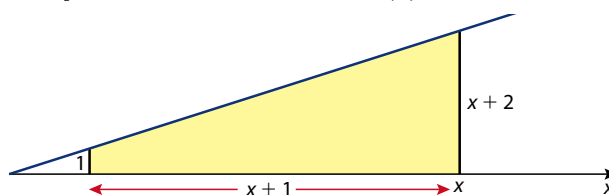
**Solution**

This is a trapezium, so the area is

$$A(x) = \frac{1}{2} (1 + (x + 2))(x + 1) = \frac{1}{2} (x^2 + 4x + 3), \text{ and}$$

$$A'(x) = \frac{1}{2} \times (2x + 4) = x + 2 = f(x).$$

Note that, in every case,
 $A'(x) = f(x)$.



The derivative of the area function $A(x)$ is the function whose graph forms the upper boundary of the region. It can be shown that this relation is true, not only for linear functions but for all continuous functions. Thus, to find the area function $A(x)$, we can look instead for a particular function whose derivative is $f(x)$. This is, of course, the anti-derivative of $f(x)$.

So, intuitively, as we have seen above, we define the area function as

$$A(x) = \int_a^x f(t) dt, \text{ that is, } A'(x) = f(x).$$

This is the trigger to the **fundamental theorem of calculus** which we will introduce in the following few pages. As we stressed at the outset, our intention here is to show you that this important theorem has its solid mathematical basis. However, examinations will not include questions requiring you to repeat the steps developed here. Just enjoy the discussion!

Before we begin the discussion, it is worth looking at some of the obvious properties of the definite integral.

Properties of the definite integral

$$1. \int_a^b f(x) dx = -\int_b^a f(x) dx$$

When we defined the definite integral $\int_a^b f(x) dx$, we implicitly assumed that $a < b$. When we reverse a and b , then Δx changes from $(b - a)/n$ to $(a - b)/n$. Therefore, the result above follows.

$$2. \int_a^a f(x) dx = 0$$

When $a = b$, then $\Delta x = 0$ and so the result above follows.

The following are a few straightforward properties:

$$3. \int_a^b c dx = c(b - a)$$

$$4. \int_a^b [f(x) \pm g(x)] dx = \int_a^b f(x) dx \pm \int_a^b g(x) dx$$

$$5. \int_a^b c f(x) dx = c \int_a^b f(x) dx, \text{ where } c \text{ is any constant}$$

$$6. \int_a^b f(x) dx = \int_a^c f(x) dx + \int_c^b f(x) dx$$

Property 6 can be demonstrated with a diagram (Figure 16.8) where the area from a to b is the sum of the two areas, i.e. $A(x) = A1 + A2$. Additionally, even if $c > b$ the relationship holds because the area from c to b in this case will be negative.

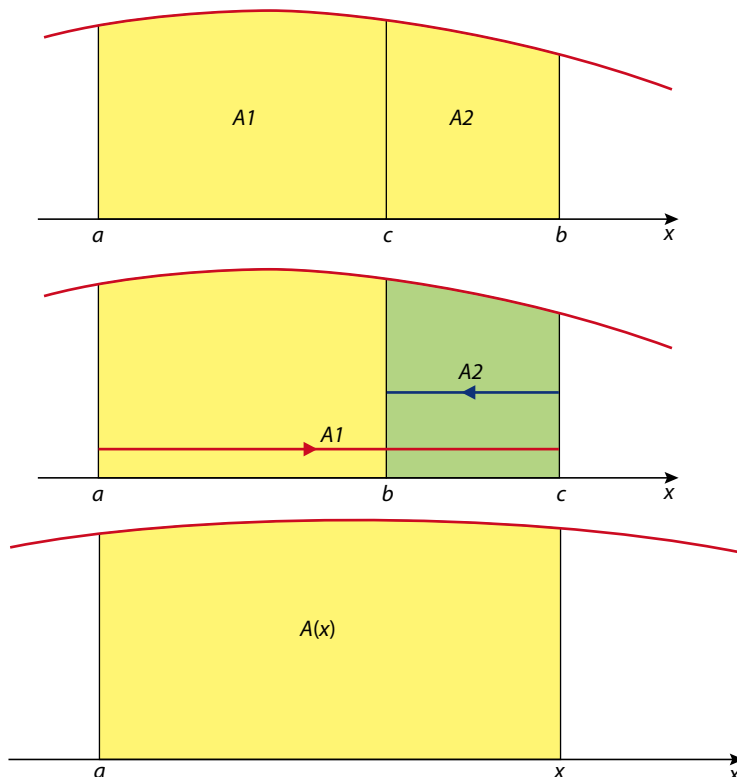
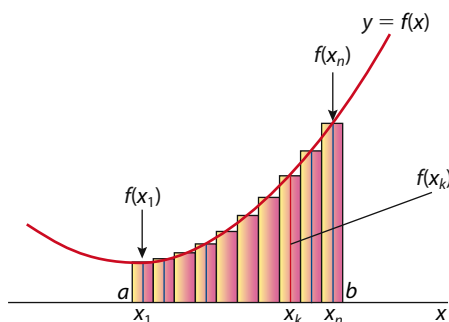

Figure 16.8

Average value of a function

As you recall from statistics, the average value of a variable is

$$\bar{X} = \frac{\sum_{i=1}^n X_i}{n}.$$



We can also think of the average value of a function in the same manner. Consider a continuous function $f(x)$ defined over a closed interval $[a, b]$. We partition this interval into n sub-intervals of equal length in a fashion similar to the previous discussion. Each interval has a length

$$\Delta x = \frac{b - a}{n}.$$

Now, the average value of $f(x)$ can be defined as

$$av(f) = \frac{f(x_1) + f(x_2) + \dots + f(x_n)}{n}.$$

Written in sigma notation:

$$av(f) = \frac{\sum_{k=1}^n f(x_k)}{n} = \frac{1}{n} \sum_{k=1}^n f(x_k)$$

However,

$$\Delta x = \frac{b - a}{n} \Rightarrow \frac{1}{n} = \frac{\Delta x}{b - a}; \text{ hence,}$$

$$av(f) = \frac{1}{n} \sum_{k=1}^n f(x_k) = \frac{\Delta x}{b - a} \sum_{k=1}^n f(x_k) = \underbrace{\frac{1}{b - a} \sum_{k=1}^n f(x_k) \Delta x}_{\text{A Riemann sum for } f \text{ on } [a, b]}$$

This leads us to the following definition of the average value of a function $f(x)$ over an interval $[a, b]$.

The average (mean value) of an integrable function $f(x)$ over an interval $[a, b]$ is given by

$$av(f) = \frac{1}{b - a} \int_a^b f(x) dx.$$

Max-min inequality

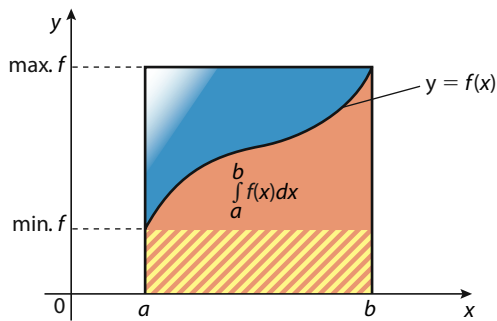

If $\text{max. } f$ and $\text{min. } f$ represent the maximum and minimum values of a non-negative continuous differentiable function $f(x)$ over an interval $[a, b]$, then the area under the curve lies between the area of the rectangle with base $[a, b]$ and the $\text{min. } f$ as height and the rectangle with $\text{max. } f$ as height.

That is,

$$(b - a)\text{min. } f \leq \int_a^b f(x) dx \leq (b - a)\text{max. } f.$$

With the assumption that $b > a$, this in turn is equivalent to

$$\text{min. } f \leq \frac{1}{b - a} \int_a^b f(x) dx \leq \text{max. } f.$$

Now using the intermediate value theorem we can ascertain that there is at

least one point $c \in [a, b]$ where $f(c) = \frac{1}{b - a} \int_a^b f(x) dx$.

The value $f(c)$ in this theorem is in fact the average value of the function.

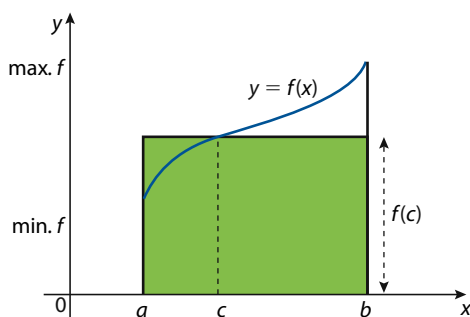

The first fundamental theorem of integral calculus

Our understanding of the definite integral as the area under the curve for $f(x)$ helps us establish the basis for the fundamental theorem of integral calculus.

In the definition of definite integral, let us make the upper limit a variable, say x . Then we will call the area between a and x , $A(x)$, i.e.

$$A(x) = \int_a^x f(t) dt.$$

Consequently,

$$A(x+h) = \int_a^{x+h} f(t) dt.$$

Now, if we want to find the derivative of $A(x)$, we evaluate.

$$\lim_{h \rightarrow 0} \frac{A(x+h) - A(x)}{h}.$$

Using the properties of definite integrals discussed earlier, we have:

$$\begin{aligned} A(x+h) - A(x) &= \int_a^{x+h} f(t) dt - \int_a^x f(t) dt \\ &= \int_x^a f(t) dt + \int_a^{x+h} f(t) dt \\ &= \int_x^{x+h} f(t) dt \end{aligned}$$

Therefore,

$$\lim_{h \rightarrow 0} \frac{A(x+h) - A(x)}{h} = \lim_{h \rightarrow 0} \frac{\int_x^{x+h} f(t) dt}{h} = \lim_{h \rightarrow 0} \frac{1}{h} \int_x^{x+h} f(t) dt.$$

Looking at this result and what we established about the average value of $f(x)$ over the interval $[x, x+h]$ we can conclude that there is a point $c \in [x, x+h]$ such that

$$f(c) = \frac{1}{h} \int_x^{x+h} f(t) dt.$$

What happens to c as h approaches 0?

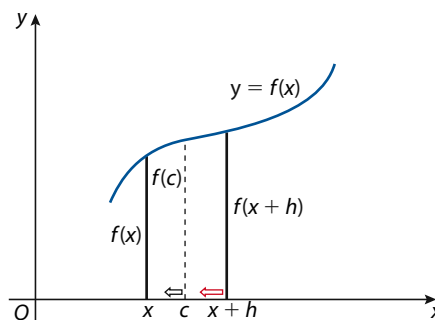

Answer: as h approaches 0, $x+h$ must approach x . This means, we are 'squeezing' c between x and a number approaching x . So, c must also approach x . That is,

$f(c) = f(x)$, and consequently

$$\lim_{h \rightarrow 0} \frac{A(x+h) - A(x)}{h} = \lim_{h \rightarrow 0} \frac{1}{h} \int_x^{x+h} f(t) dt = f(c) = f(x).$$

This last equation is stating that

$$\frac{d}{dx}(A(x)) = A'(x) = \frac{d}{dx}\left(\int_a^x f(t)dt\right) = f(x).$$

This very powerful statement is called the first fundamental theorem of integral calculus. In essence it says that the processes of integration and derivation are inverses of one another.

Note: It is important to remember that $\int_a^x f(t)dt$ is a function of x !

Example 26

Find each of the following.

a) $\frac{d}{dx} \int_{-e}^x \sec^2 t dt$

b) $\frac{d}{dx} \int_0^x \frac{dt}{1+t^4}$

c) $\frac{d}{dx} \int_x^\pi \frac{1}{1+t^4} dt$

d) $\frac{d}{dx} \int_0^{2x+x^3} \frac{1}{1+t^4} dt$

e) $\frac{d}{dx} \int_x^{2x+x^3} \frac{1}{1+t^4} dt$

Solution

a) This is a direct application of the fundamental theorem.

$$\frac{d}{dx} \int_{-e}^x \sec^2 t dt = \sec^2 x$$

b) This is also straightforward.

$$\frac{d}{dx} \int_0^x \frac{dt}{1+t^4} = \frac{1}{1+x^4}$$

c) In this exercise, we need to rewrite the expression before we perform the calculation.

$$\frac{d}{dx} \int_x^\pi \frac{1}{1+t^4} dt = \frac{d}{dx} \int_\pi^x -\frac{1}{1+t^4} dt = -\frac{d}{dx} \int_x^\pi \frac{1}{1+t^4} dt = \frac{-1}{1+x^4}$$

d) Remembering that this is a function of x , and that the upper limit

is a function of x , which makes $\int_0^{2x+x^3} \frac{1}{1+t^4} dt$ a composite of $\int_0^u \frac{1}{1+t^4} dt$ and $u = 2x + x^3$. So, we have to resort to the chain rule!

$$\begin{aligned} \frac{d}{dx} \int_0^{2x+x^3} \frac{1}{1+t^4} dt &= \left(\frac{d}{du} \int_0^u \frac{1}{1+t^4} \right) \left(\frac{du}{dx} \right) \\ &= \frac{1}{1+u^4} \cdot \frac{du}{dx} \\ &= \frac{1}{1+(2x+x^3)^4} \cdot (2+3x^2) \\ &= \frac{2+3x^2}{1+(2x+x^3)^4} \end{aligned}$$

e) Again, here we need to rewrite the integral before evaluation.

$$\begin{aligned}\frac{d}{dx} \int_x^{2x+x^3} \frac{1}{1+t^4} dt &= \frac{d}{dx} \left(\int_x^k \frac{1}{1+t^4} dt + \int_k^{2x+x^3} \frac{1}{1+t^4} dt \right) \\ &= \frac{2+3x^2}{1+(2x+x^3)^4} - \frac{1}{1+x^4}\end{aligned}$$

The second fundamental theorem of integral calculus

Recall that $A(x) = \int_a^x f(t) dt$. If $F(x)$ is any anti-derivatives of $f(x)$, then applying what we learned in earlier sections:

$$F(x) = A(x) + c \text{ where } c \text{ is an arbitrary constant.}$$

Now,

$$F(b) = A(b) + c = \int_a^b f(t) dt + c, \text{ and}$$

$$F(a) = A(a) + c = \int_a^a f(t) dt + c = 0 + c, \text{ and hence}$$

$$\begin{aligned}F(b) - F(a) &= \int_a^b f(t) dt + c - c \\ &= \int_a^b f(t) dt.\end{aligned}$$

Second fundamental theorem of calculus

$$\int_a^b f(t) dt = F(b) - F(a)$$

The fundamental theorem is also referred to as the **evaluation theorem**.

Also, since we know that $F'(x)$ is the rate of change in $F(x)$ with respect to x and that $F(b) - F(a)$ is the change in y when x changes from a to b , we can reformulate the theorem in words.

The integral of a rate of change is the **total change**.

$$\int_a^b F'(x) dx = F(b) - F(a)$$

Here are a few instances where this applies:

1. If $V'(t)$ is the rate at which a liquid flows into or out of a container at time t , then

$$\int_{t_1}^{t_2} V'(t) dt = V(t_2) - V(t_1)$$

is the change in the amount of liquid in the container between time t_1 and t_2 .

2. If the rate of growth of a population is $n'(t)$, then

$$\int_{t_1}^{t_2} n'(t) dt = n(t_2) - n(t_1)$$

is the increase (decrease!) in population during the time period from t_1 to t_2 .

3. Displacement situations are described separately later in the chapter.

This theorem has many other applications in calculus and several other fields. It is a very powerful tool to deal with problems of area, volume and work among other applications. In this book, we will apply it to finding areas between functions and volumes of revolution as well as displacement problems.

Notation:

We will use the following notation:

$$\int_a^b f(t) dt = F(x) \Big|_a^b = F(b) - F(a)$$

Example 27

a) Evaluate the integral $\int_{-1}^3 x^5 dx$.

b) Evaluate the integral $\int_0^4 \sqrt{x} dx$.

c) Evaluate the integral $\int_{\pi}^{2\pi} \cos \theta d\theta$.

d) Evaluate the integral $\int_1^2 \frac{4 + u^2}{u^3} du$.

Solution

a) $\int_{-1}^3 x^5 dx = \left[\frac{x^6}{6} \right]_{-1}^3 = \frac{3^6}{6} - \frac{1}{6} = \frac{364}{6}$

b) $\int_0^4 \sqrt{x} dx = \left[\frac{2}{3} x^{3/2} \right]_0^4 = \frac{2}{3} 4^{3/2} - 0 = \frac{16}{3}$

c) $\int_{\pi}^{2\pi} \cos \theta d\theta = \left[\sin \theta \right]_{\pi}^{2\pi} = 0 - 0 = 0$

d) $\int_1^2 \frac{4 + u^2}{u^3} du = \int_1^2 \left(\frac{4}{u^3} + \frac{1}{u} \right) du = \left[4 \cdot \frac{u^{-2}}{-2} + \ln|u| \right]_1^2$
 $= \left[-2u^{-2} + \ln u \right]_1^2$
 $= (-2 \cdot 2^{-2} + \ln 2) - (-2 \cdot 1 + \ln 1) = -\frac{1}{2} + \ln 2 + 2$
 $= \frac{3}{2} + \ln 2$

Using substitution with definite integral

In Section 16.1 we discussed the use of substitution to evaluate integrals in cases that are not easily recognized. We established the following rule:

$$\int f(u(x)) \cdot u'(x) dx = \int f(u) du = F(u(x)) + c = F(x) + c$$

When evaluating definite integrals by substitution, two methods are available.

- 1 Evaluate the indefinite integral first, revert to the original variable, and then use the fundamental theorem. For example, to evaluate

$$\int_0^{\frac{\pi}{3}} \tan^5 x \sec^2 x dx,$$

we find the indefinite integral

$$\int \tan^5 x \sec^2 x dx = \int u^5 du = \frac{1}{6} u^6 = \frac{1}{6} \tan^6 x,$$

and then we use the fundamental theorem, i.e.

$$\int_0^{\frac{\pi}{3}} \tan^5 x \sec^2 x dx = \left. \frac{1}{6} \tan^6 x \right|_0^{\frac{\pi}{3}} = \frac{1}{6} (\sqrt{3})^6 = \frac{27}{6} = \frac{9}{2}.$$

- 2 Use the following 'substitution rule' for definite integrals:

$$\int_a^b f(u(x)) u'(x) dx = \int_{u(a)}^{u(b)} f(u) du$$

Proof:

If $F(x)$ is an anti-derivative of $f(x)$, then by the fundamental theorem

$$\int_b^a f(u(x)) u'(x) dx = \left. F(u(x)) \right|_a^b = F(u(b)) - F(u(a)).$$

Also,

$$\int_{u(a)}^{u(b)} f(u) du = \left. F(u) \right|_{u(a)}^{u(b)} = F(u(b)) - F(u(a)).$$

Therefore, to evaluate

$$\int_0^{\frac{\pi}{3}} \tan^5 x \sec^2 x dx,$$

letting $u = \tan x \Rightarrow u\left(\frac{\pi}{3}\right) = \sqrt{3}$, $u(0) = 0$, and so

$$\int_0^{\frac{\pi}{3}} \tan^5 x \sec^2 x dx = \int_0^{\sqrt{3}} u^5 du = \left. \frac{1}{6} u^6 \right|_0^{\sqrt{3}} = \frac{9}{2}.$$

Example 28

Evaluate $\int_2^6 \sqrt{4x+1} dx$.

Solution

Let $u = 4x + 1$, then $du = 4dx$. The limits of integration are

$u(2) = 9$ and $u(6) = 25$, therefore

$$\begin{aligned} \int_2^6 \sqrt{4x+1} dx &= \frac{1}{4} \int_9^{25} \sqrt{u} du = \frac{1}{4} \left(\frac{2}{3} u^{\frac{3}{2}} \right) \Big|_9^{25} \\ &= \frac{1}{6} (125 - 27) = \frac{49}{3}. \end{aligned}$$

Observe that using this method, we do not return to the original variable of integration. We simply evaluate the 'new' integral between the appropriate values of u .

Exercise 16.4

In questions 1–42, evaluate the integral.

$$1 \int_{-2}^1 (3x^2 - 4x^3) dx$$

$$2 \int_2^7 8 dx$$

$$3 \int_1^5 \frac{2}{t^3} dt$$

$$4 \int_2^2 (\cos t - \tan t) dt$$

$$5 \int_1^7 \frac{2x^2 - 3x + 5}{\sqrt{x}} dx$$

$$6 \int_0^\pi \cos \theta d\theta$$

$$7 \int_0^\pi \sin \theta d\theta$$

$$8 \int_3^1 (5x^4 + 3x^2) dx$$

$$9 \int_1^3 \frac{u^5 + 2}{u^2} du$$

$$10 \int_1^e \frac{2 dx}{x}$$

$$11 \int_1^3 \frac{2x}{x^2 + 2} dx$$

$$12 \int_1^3 (2 - \sqrt{x})^2 dx$$

$$13 \int_0^{\frac{\pi}{4}} 3 \sec^2 \theta d\theta$$

$$14 \int_0^1 (8x^7 + \sqrt{\pi}) dx$$

$$15 \text{ a) } \int_0^2 |3x| dx$$

$$\text{b) } \int_{-2}^0 |3x| dx$$

$$\text{c) } \int_{-2}^2 |3x| dx$$

$$16 \int_0^{\frac{\pi}{2}} \sin 2x dx$$

$$17 \int_1^9 \frac{1}{\sqrt{x}} dx$$

$$18 \int_{-2}^2 (e^x - e^{-x}) dx$$

$$19 \int_{-1}^1 \frac{dx}{1 + x^2}$$

$$20 \int_0^{\frac{1}{2}} \frac{dx}{\sqrt{1 - x^2}}$$

$$21 \int_{-1}^1 \frac{dx}{\sqrt{4 - x^2}}$$

$$22 \int_{-2}^0 \frac{dx}{4 + x^2}$$

$$23 \int_0^4 \frac{x^3 dx}{\sqrt{x^2 + 1}}$$

$$24 \int_1^{\sqrt{e}} \frac{\sin(\pi \ln x)}{x} dx$$

$$25 \int_e^{e^2} \frac{dt}{t \ln t}$$

$$26 \int_{-1}^2 3x\sqrt{9 - x^2} dx$$

$$27 \int_{-\frac{\pi}{3}}^{\frac{2\pi}{3}} \frac{\sin x}{\sqrt{3 + \cos x}} dx$$

$$28 \int_e^{e^2} \frac{\ln x}{x} dx$$

$$30 \int_1^{\sqrt{e}} \frac{dx}{x\sqrt{1 - (\ln x)^2}}$$

$$32 \int_{\ln 2}^{\ln(\frac{2}{\sqrt{3}})} \frac{e^{-2x} dx}{\sqrt{1 - e^{-4x}}}$$

$$34 \int_0^{\sqrt{\pi}} 7x \cos x^2 dx$$

$$36 \int_0^1 \frac{\sqrt{3}x}{\sqrt{4 - 3x^4}} dx$$

$$38 \int_1^{\sqrt{2}} \frac{x dx}{3 + x^4}$$

$$40 \int_0^{\frac{\pi}{4}} e^{\sin 2\theta} \cos 2\theta d\theta$$

$$42 \int_0^{\sqrt{\ln \pi}} 4te^{t^2} \sin(e^{t^2}) dt$$

$$29 \int_1^{\sqrt{3}} \frac{\sqrt{\arctan x}}{1 + x^2} dx$$

$$31 \int_{-\ln 2}^{\ln 2} \frac{e^{2x}}{e^{2x} + 9} dx$$

$$33 \int_0^{\frac{\pi}{4}} \sqrt{\tan x} \sec^2 x dx$$

$$35 \int_{\pi^2}^{4\pi^2} \frac{\sin \sqrt{x}}{\sqrt{x}} dx$$

$$37 \int_0^{\frac{2}{\sqrt{3}}} \frac{dx}{9 + 4x^2}$$

$$39 \int_0^{\frac{\pi}{6}} (1 - \sin 3t) \cos 3t dt$$

$$41 \int_0^{\frac{\pi}{8}} (3 + e^{\tan 2t}) \sec^2 2t dt$$

In questions 43–47, find the average value of the given function over the given interval.

$$43 \ x^4, [1, 2]$$

$$44 \ \cos x, [0, \frac{\pi}{2}]$$

$$45 \ \sec^2 x, [\frac{\pi}{6}, \frac{\pi}{4}]$$

$$46 \ e^{-2x}, [0, 4]$$

$$47 \ \frac{e^{3x}}{1 + e^{6x}}, [-\ln 3, 0]$$

In questions 48–55, find the indicated derivative.

$$48 \ \frac{d}{dx} \int_2^{x^2} \frac{\sin t}{t} dt$$

$$49 \ \frac{d}{dt} \int_t^3 \frac{\sin x}{x} dx$$

$$50 \ \frac{d}{dx} \int_{x^2}^0 \frac{\sin t}{t} dt$$

$$51 \ \frac{d}{dx} \int_0^{x^2} \frac{\sin u}{u} du$$

$$52 \ \frac{d}{dt} \int_{-\pi}^t \frac{\cos y}{1 + y^2} dy$$

$$53 \ \frac{d}{dx} \int_{ax}^{bx} \frac{dt}{5 + t^4}$$

$$54 \ \frac{d}{d\theta} \int_{\sin \theta}^{\cos \theta} \frac{1}{1 - x^2} dx$$

$$55 \ \frac{d}{dx} \int_5^{x^{\frac{1}{4}}} e^{t^4 + 3t^2} dt$$

$$56 \ \text{Does the function } F(x) = \int_0^{2x-x^2} \cos\left(\frac{1}{1+t^2}\right) dt \text{ have an extreme value?}$$

$$57 \ \text{a) Find } \int_0^k \frac{dx}{3x+2}, \text{ giving your answer in terms of } k.$$

$$\text{b) Given that } \int_0^k \frac{dx}{3x+2} = 1, \text{ calculate the value of } k.$$

58 Given that $p, q \in \mathbb{N}$, show that

$$\int_0^1 x^p(1-x)^q dx = \int_0^1 x^q(1-x)^p dx.$$

Do not attempt to evaluate the integrals.

59 Given that $k \in \mathbb{N}$, evaluate the integral.

a) $\int x(1-x)^k dx$ b) $\int_0^1 x(1-x)^k dx$

60 Let $F(x) = \int_3^x \sqrt{5t^2 + 2} dt$. Find

a) $F(3)$ b) $F'(3)$ c) $F''(3)$

61 Show that the function

$$f(x) = \int_x^{3x} \frac{dt}{t}$$

is constant over the set of positive real numbers.

16.5 Integration by method of partial fractions (Optional)

In this section, we will see how rational functions with polynomial denominators can be integrated. For example, if we were to find the indefinite integral $\int \frac{x+1}{x^2+5x+6} dx$, we first decompose the integrand into partial fractions and then the integration process would be straightforward.

$$\frac{x+1}{x^2+5x+6} \equiv \frac{a}{x+2} + \frac{b}{x+3}$$

(See Section 3.6 for details.)

After solving for a and b we can perform the integration:

$$\begin{aligned} \int \frac{x+1}{x^2+5x+6} &\equiv \int \left(\frac{-1}{x+2} + \frac{2}{x+3} \right) dx = -\ln|x+2| + 2\ln|x+3| + c \\ &= \ln \left| \frac{(x+3)^2}{x+2} \right| + c \end{aligned}$$

Example 29

Find the indefinite integral $\int \frac{3x-1}{x^2+4x+4} dx$.

Solution

Using partial fractions will make the work simpler than otherwise.

From Example 42 of Section 3.6 we know:

$$\frac{3x-1}{x^2+4x+4} = \frac{3}{x+2} - \frac{7}{(x+2)^2}$$

Hence, the integral can be rewritten as:

$$\int \frac{3x-1}{x^2+4x+4} dx = \int \frac{3}{x+2} dx - \int \frac{7}{(x+2)^2} dx$$

These two integrals can be found by inspection, giving:

$$\int \frac{3x-1}{x^2+4x+4} dx = 3 \ln|x+2| + \frac{7}{x+2} + c$$

Example 30

Find the indefinite integral $\int \frac{2}{x^3+2x^2+2x} dx$.

Solution

Again, from Example 43 of Section 3.6, we have:

$$\frac{2}{x^3+2x^2+2x} = \frac{1}{x} - \frac{x+2}{x^2+2x+2}$$

Hence, we can write the integral as:

$$\begin{aligned} \int \frac{2}{x^3+2x^2+2x} dx &= \int \frac{dx}{x} - \frac{x+2}{x^2+2x+2} dx = \int \frac{dx}{x} - \int \frac{x+1+1}{x^2+2x+2} dx \\ &= \int \frac{dx}{x} - \frac{1}{2} \int \frac{2x+4}{x^2+2x+2} dx = \int \frac{dx}{x} - \frac{1}{2} \int \frac{2x+4}{(x+1)^2+1} dx \\ &= \ln|x| - \frac{1}{4} \ln(x^2+2x+2) - \arctan(x+1) + c \end{aligned}$$

Example 31

Find the indefinite integral $\int \frac{5x^2+16x+17}{2x^3+9x^2+7x-6} dx$.

Solution

Again from Example 41 of Section 3.6 we have:

$$\begin{aligned} \int \frac{5x^2+16x+17}{2x^3+9x^2+7x-6} dx &= \int \frac{3}{2x-1} dx - \int \frac{1}{x+2} dx + \int \frac{2}{x+3} dx \\ &= \frac{3}{2} \ln|2x-1| - \ln|x+2| + 2 \ln|x+3| + c \end{aligned}$$

Example 32

Evaluate $\int \frac{3x-1}{x^3+8} dx$.

Solution

We first factorize the denominator:

$$x^3+8 = (x+2)(x^2-2x+4)$$

Now, by using partial fractions we have:

$$\frac{3x-1}{x^3+8} = \frac{a}{x+2} + \frac{bx+c}{x^2-2x+4}$$

Solving for a , b , and c will yield:

$$\begin{aligned} 3x-1 &\equiv a(x^2-2x+4) + (bx+c)(x+2) \\ &= (a+b)x^2 + (2b-2a+c)x + 4a+2c \end{aligned}$$

This implies:
$$\begin{cases} a + b = 0 \\ 2b - 2a + c = 3 \\ 4a + 2c = -1 \end{cases}$$

Solving this system of equations will yield:

$$a = -\frac{7}{12}, b = \frac{7}{12}, c = \frac{2}{3}$$

Therefore,

$$\int \frac{3x-1}{x^3+8} dx = \int \frac{-\frac{7}{12}}{x+2} dx + \int \frac{\frac{7}{12}x + \frac{2}{3}}{x^2-2x+4} dx$$

Finally, using what you learned so far you can verify the answer to be:

$$\int \frac{3x-1}{x^3+8} dx = -\frac{7}{12} \ln|x+2| + \frac{7}{24} \ln(x^2-2x+4) - \frac{5\sqrt{3}}{12} \arctan\left(\frac{x-1}{\sqrt{3}}\right) + c$$

Summary of procedures

In this book we will only consider five general cases. They are outlined below.

Possible cases for partial fractions

- 1 Denominator is a quadratic** that factorises into two distinct linear factors, and numerator $p(x)$ is a constant or linear.

$$\frac{p(x)}{(ax+b)(cx+d)} = \frac{A}{ax+b} + \frac{B}{cx+d}$$

- 2 Denominator is a quadratic** that factorises into two repeated linear factors, and numerator $p(x)$ is a constant or linear.

$$\frac{p(x)}{(ax+b)^2} = \frac{A}{ax+b} + \frac{B}{(ax+b)^2}$$

- 3 Denominator is a cubic** that factorises into three repeated linear factors, and numerator $p(x)$ is a constant, linear or quadratic.

$$\frac{p(x)}{(ax+b)^3} = \frac{A}{ax+b} + \frac{B}{(ax+b)^2} + \frac{C}{(ax+b)^3}$$

- 4 Denominator is a cubic** that factorises into one linear factor and one quadratic factor (that cannot be factorised), and numerator $p(x)$ is a constant, linear or quadratic.

$$\frac{p(x)}{(ax+b)(cx^2+dx+e)} = \frac{A}{ax+b} + \frac{Bx+C}{cx^2+dx+e}$$

- 5 Denominator is a cubic** that factorises into three distinct linear factors, and numerator $p(x)$ is a constant, linear or quadratic.

$$\frac{p(x)}{(ax+b)(cx+d)(ex+f)} = \frac{A}{ax+b} + \frac{B}{cx+d} + \frac{C}{ex+f}$$



A consequence of the Fundamental Theorem of Algebra (see margin note in Section 3.3) guarantees that any polynomial with real coefficients can only have factors that are linear or quadratic.

Exercise 16.5

Evaluate each integral.

1 $\int \frac{5x+1}{x^2+x-2} dx$

2 $\int \frac{x+4}{x^2-2} dx$

3 $\int \frac{x+2}{x^2+4x+3} dx$

4 $\int \frac{5x^2+20x+6}{x^3+2x^2+x} dx$

5 $\int \frac{2x^2+x-12}{x^3+5x^2+6x} dx$

6 $\int \frac{4x^2+2x-1}{x^3+x^2} dx$

7 $\int \frac{3}{x^2+x-2} dx$

8 $\int \frac{5-x}{2x^2+x-1} dx$

9 $\int \frac{3x+4}{(x+2)^2} dx$

10 $\int \frac{12}{x^4-x^3-2x^2} dx$

11 $\int \frac{2}{x^3+x} dx$

12 $\int \frac{x+2}{x^3+3x} dx$

13 $\int \frac{3x+2}{x^3+6x} dx$

14 $\int \frac{2x+3}{x^3+8x} dx$

15 $\int \frac{x+5}{x^3-4x^2-5x} dx$

16.6 Areas

We have seen how the area between a curve, defined by $y = f(x)$, and the x -axis can be computed by the integral $\int_a^b f(x) dx$ on an interval $[a, b]$, where $f(x) \geq 0$. In this section, we shall find that integration can be used to find the area of more general regions between curves.

Areas between curves of functions of the form $y = f(x)$ and the x -axis

If the function $y = f(x)$ is always above the x -axis, finding the area is a straightforward computation of the integral $\int_a^b f(x) dx$.

Example 33

Find the area under the curve $f(x) = x^3 - x + 1$ and the x -axis over the interval $[-1, 2]$.

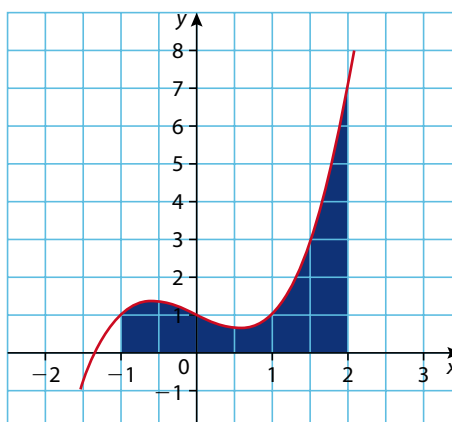

Solution

This area is simply

$$\int_{-1}^2 (x^3 - x + 1) dx = \left[\frac{x^4}{4} - \frac{x^2}{2} + x \right]_{-1}^2$$

$$= (4 - 2 + 2) - \left(\frac{1}{4} - \frac{1}{2} - 1 \right) = 5\frac{1}{4}.$$

Using your GDC, this is done by simply choosing the 'MATH' menu, then the 'fnInt' menu item.

Or, you can type in your function and then go to the 'CALC' menu, where you choose ' $\int f(x) dx$ ' and type in your integration limits. Here is what you see.

```
fnInt(X^3-X+1,X,
-1,2)
5.25
```

```
CALCULATE
1:value
2:zero
3:minimum
4:maximum
5:intersect
6:dy/dx
7: $\int f(x) dx$ 
```

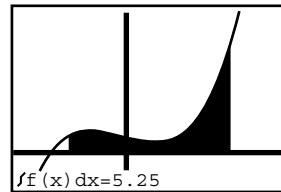
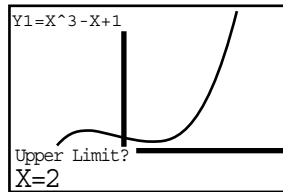

In some cases, you will have to adjust how you work. This is the case when the graph intersects the x -axis. Since you are interested in the area bounded by the curve and the interval $[a, b]$ on the x -axis, you do not want the 'signed' areas to cancel each other. This is why you have to split the process into different sub-intervals where you take the absolute values of the areas found and add them.

Example 34

Find the area under the curve $f(x) = x^3 - x - 1$ and the x -axis over the interval $[-1, 2]$.

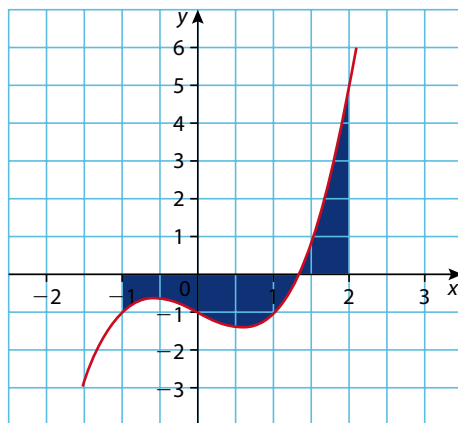

Solution

As you see from the diagram, a part of the graph is below the x -axis, and its area will be negative. If you try to integrate this function without paying attention to the intersection with the x -axis, this is what you get:

$$\int_{-1}^2 (x^3 - x - 1) dx = \left[\frac{x^4}{4} - \frac{x^2}{2} - x \right]_{-1}^2$$

$$= (4 - 2 - 2) - \left(\frac{1}{4} - \frac{1}{2} + 1 \right) = -\frac{3}{4}$$

This integration has to be split before we start. However, this is a function where you cannot find the intersection point. So, we either use our GDC to find the intersection, or we just take the absolute values of the different parts of the region. This is done by integrating the absolute value of the function:

$$\text{Area} = \int_a^b |f(x)| dx$$

$$\text{Hence, area} = \int_{-1}^2 |(x^3 - x - 1)| dx.$$

As we said earlier, this is not easy to find given the difficulty with the x -intercept. It is best if we make use of a GDC.

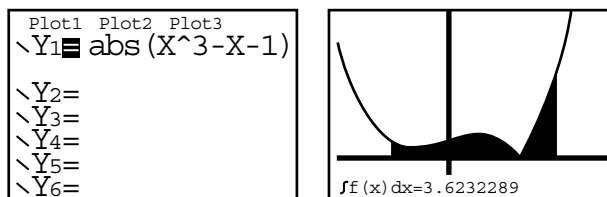

Or, using 'fnInt' directly:

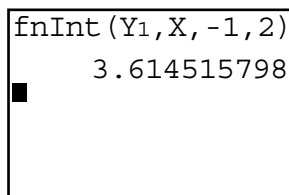

The difference between them is that the latter is more of a rough approximation than the first.

Example 35

Find the area enclosed by the graph of the function $f(x) = x^3 - 4x^2 + x + 6$ and the x -axis.

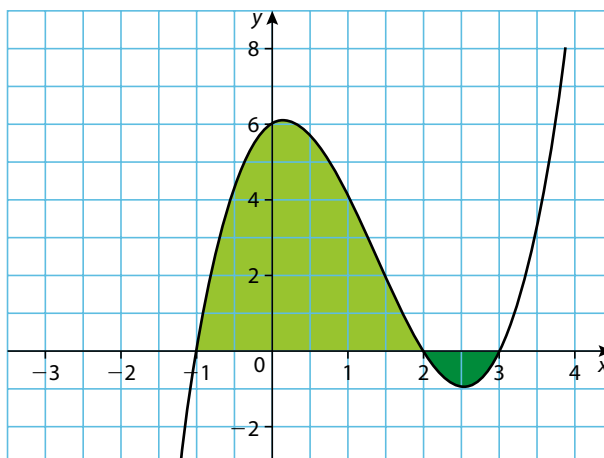

Solution

This function intersects the x -axis at three points where $x = -1, 2$ and 3 . To find the area, we split it into two and then add the absolute values:

$$\begin{aligned}\text{Area} &= \int_{-1}^3 |f(x)| dx = \int_{-1}^2 f(x) dx + \int_2^3 (-f(x)) dx \\ &= \int_{-1}^2 (x^3 - 4x^2 + x + 6) dx + \int_2^3 (-x^3 + 4x^2 - x - 6) dx \\ &= \left[\frac{x^4}{4} - \frac{4x^3}{3} + \frac{x^2}{2} + 6x \right]_{-1}^2 + \left[-\frac{x^4}{4} + \frac{4x^3}{3} - \frac{x^2}{2} - 6x \right]_2^3 \\ &= \frac{45}{4} + \frac{7}{12} = \frac{71}{6}\end{aligned}$$

Area between curves

In some practical problems, you may have to compute the area between two curves. Suppose $f(x)$ and $g(x)$ are functions such that $f(x) \geq g(x)$ on the interval $[a, b]$, as shown in the diagram. Note that we do not insist that both functions are non-negative, but we begin by showing that case for demonstration purposes.

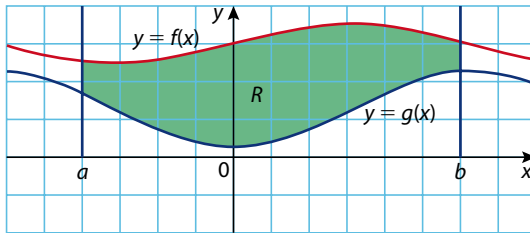

To find the area of the region R between the curves from $x = a$ to $x = b$, we subtract the area between the lower curve $g(x)$ and the x -axis from the area between the upper curve $f(x)$ and the x -axis; that is,

$$\text{Area of } R = \int_a^b f(x) dx - \int_a^b g(x) dx = \int_a^b [f(x) - g(x)] dx.$$

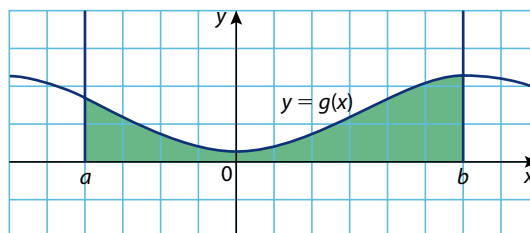
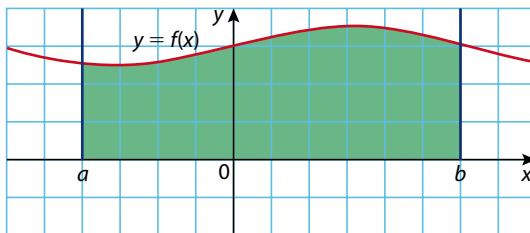

The fact just mentioned applies to all functions, not only positive functions. These facts are used to define the area between curves.

If $f(x)$ and $g(x)$ are functions such that $f(x) \geq g(x)$ on the interval $[a, b]$, then the area between the two curves is given by

$$A = \int_a^b [f(x) - g(x)] dx.$$

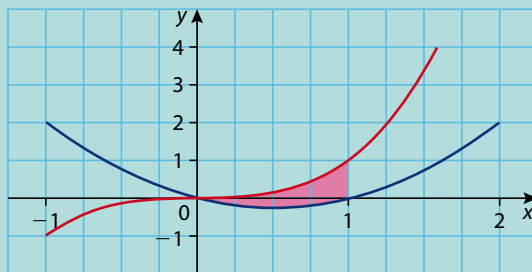

Example 36

Find the area of the region between the curves $y = x^3$ and $y = x^2 - x$ on the interval $[0, 1]$. (See diagram above.)

Solution

$y = x^3$ appears to be higher than $y = x^2 - x$ with one intersection at $x = 0$. Thus, the required area is

$$A = \int_0^1 [x^3 - (x^2 - x)] dx = \left[\frac{x^4}{4} - \frac{x^3}{3} + \frac{x^2}{2} \right]_0^1 = \frac{5}{12}.$$

In order to take all cases into consideration, we will present here another case where you must be very careful of how you calculate the area. This is the case where the two functions in question intersect at more than one point. We will clarify this with an example.

Example 37

Find the area of the region bounded by the curves $y = x^3 + 2x^2$ and $y = x^2 + 2x$.

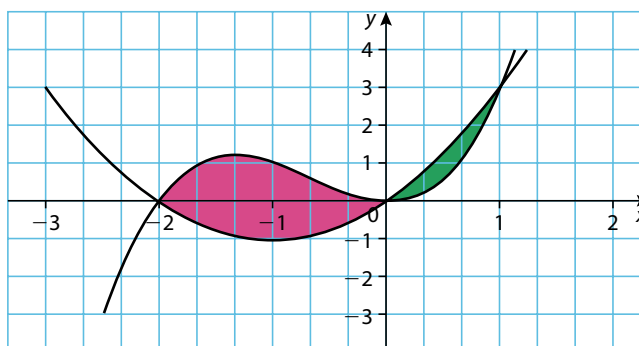

Solution

The two curves intersect when

$$x^3 + 2x^2 = x^2 + 2x \Rightarrow x^3 + x^2 - 2x = 0 \Rightarrow x(x + 2)(x - 1) = 0,$$

i.e. when $x = -2, 0$ or 1 .

The area is equal to

$$\begin{aligned}
 A &= \int_{-2}^0 [x^3 + 2x^2 - (x^2 + 2x)] dx + \int_0^1 [x^2 + 2x - (x^3 + 2x^2)] dx \\
 &= \int_{-2}^0 [x^3 + x^2 - 2x] dx + \int_0^1 [-x^2 + 2x - x^3] dx \\
 &= \left[\frac{x^4}{4} + \frac{x^3}{3} - x^2 \right]_{-2}^0 + \left[-\frac{x^4}{4} - \frac{x^3}{3} + x^2 \right]_0^1 \\
 &= 0 - \left[\frac{16}{4} - \frac{8}{3} - 4 \right] + \left[-\frac{1}{4} - \frac{1}{3} + 1 \right] - 0 = \frac{37}{12}.
 \end{aligned}$$

This discussion leads us to stating the general expression you should use in evaluating areas between curves.

If $f(x)$ and $g(x)$ are continuous functions on the interval $[a, b]$, the area between the two curves is given by

$$A = \int_a^b |f(x) - g(x)| dx.$$

The above computation can be done with your GDC as follows:

```

Plot1 Plot2 Plot3
\Y1= X^3+2X^2
\Y2= X^2+2X
\Y3= abs(Y1-Y2)
\Y4=
\Y5=
\Y6=
\Y7=
  
```

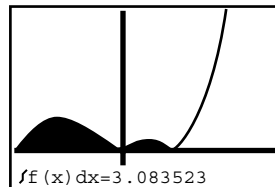
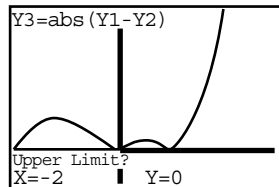

Areas along the y -axis

If we were to find the area enclosed by $y = 1 - x$ and $y^2 = x + 1$, it would be best to treat the region between them by regarding x as a function of y as you see in the graph here.

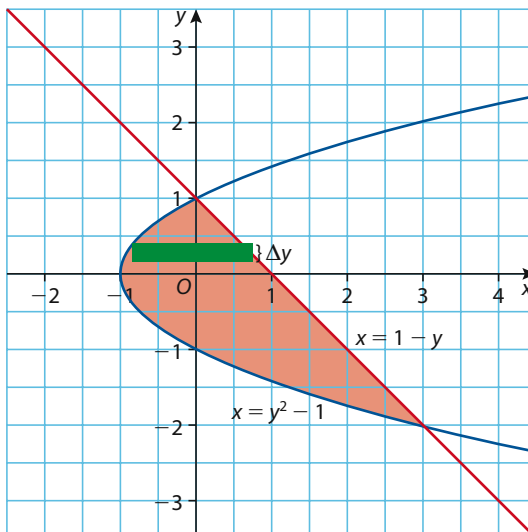

The area of the shaded region can be calculated using the following integral:

$$\begin{aligned} A(y) &= \int_{-1}^1 |(1-y) - (y^2-1)| dy \\ &= \int_{-2}^1 |2-y-y^2| dy = \left| 2y - \frac{y^2}{2} - \frac{y^3}{3} \right|_{-2}^1 = \frac{9}{2} \end{aligned}$$

If we were to use y as a function of x , then the calculation would have involved calculating the area by dividing the interval into two: $[-1, 0]$ and $[0, 3]$.

In the first part the area is enclosed between $y = \sqrt{x+1}$ and $y = -\sqrt{x+1}$, and the area in the second part is enclosed by $y = 1-x$ and $y = -\sqrt{x+1}$:

$$2 \int_{-1}^0 \sqrt{x+1} dx + \int_0^3 ((1-x) - (-\sqrt{x+1})) dx$$

(Calculation is left as an exercise.)

Exercise 16.6

In questions 1–22, sketch the region whose area you are asked for, and then compute the required area. In each question, find the area of the region bounded by the given curves.

- | | |
|---|---|
| 1 $y = x + 1, y = 7 - x^2$ | 2 $y = \cos x, y = x - \frac{\pi}{2}, x = -\pi$ |
| 3 $y = 2x, y = x^2 - 2$ | 4 $y = x^3, y = x^2 - 2, x = 1$ |
| 5 $y = x^6, y = x^2$ | 6 $y = 5x - x^2, y = x^2$ |
| 7 $y = 2x - x^3, y = x - x^2$ | 8 $y = \sin x, y = 2 - \sin x$ (one period) |
| 9 $y = \frac{x}{2}, y = \sqrt{x}, x = 9$ | 10 $y = \frac{x^4}{10}, y = 3x - x^3$ |
| 11 $y = \frac{1}{x}, y = \frac{1}{x^3}, x = 8$ | 12 $y = 2 \sin x, y = \sqrt{3} \tan x, -\frac{\pi}{4} \leq x \leq \frac{\pi}{4}$ |
| 13 $y = x - 1$ and $y^2 = 2x + 6$ | 14 $x = 2y^2$ and $x = 4 + y^2$ |
| 15 $4x + y^2 = 12$ and $y = x$ | 16 $x - y = 7$ and $x = 2y^2 - y + 3$ |
| 17 $x = y^2$ and $x = 2y^2 - y - 2$ | |
| 18 $y = x^3 + 2x^2, y = x^3 - 2x, x = -3$ and $x = 2$ | |
| 19 $y = \sec^2 x, y = \sec x \tan x, x = -\frac{\pi}{3}$ and $x = \frac{\pi}{6}$ | |
| 20 $y = x^3 + 1$ and $y = (x + 1)^2$ | 21 $y = x^3 + x$ and $y = 3x^2 - x$ |
| 22 $y = 3 - \sqrt{x}$ and $y = \frac{2\sqrt{x} + 1}{2\sqrt{x}}$ | |
| 23 Find the area of the shaded region. | |

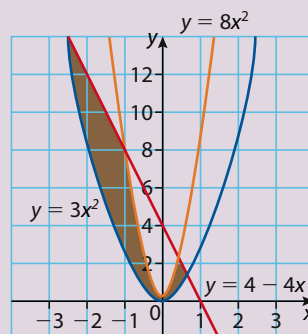

- 24 Find the area of the region enclosed by $y = e^x$, $x = 0$ and the tangent to $y = e^x$ at $x = 1$.
- 25 Find the area of the region inside the 'loop' in the graph of the curve $y^2 = x^4(x + 3)$.
- 26 Find the area enclosed by the curve $y^2 = 2x^2 - 4x^4$.
- 27 Find the area of the region enclosed by $x = 3y^2$ and $x = 12y - y^2 - 5$.
- 28 Find the area of the region enclosed by $y = (x - 2)^2$ and $y = x(x - 4)^2$.
- 29 Find a value for $m > 0$ such that the area under the graph of $y = e^{2x}$ over the interval $[0, m]$ is 3 square units.
- 30 Find the area of the region bounded by $y = x^3 - 4x^2 + 3x$ and the x -axis.

16.7 Volumes with integrals

Recall that the underlying principle for finding the area of a plane region is to divide the region into thin strips, approximate the area of each strip by the area of a rectangle, and then add the approximations and take the limit of the sum to produce an integral for the area. The same strategy can be used to find the volume of a solid.

The idea is to divide the solid into thin slabs, approximate the volume of each slab, add the approximations and take the limit of the sum to produce an integral of the volume.

Given a solid whose volume is to be computed, we start by taking cross-sections perpendicular to the x -axis as shown in Figure 16.9. Each slab will be approximated by a cylindrical solid whose volume will be equal to the product of its base times its height.

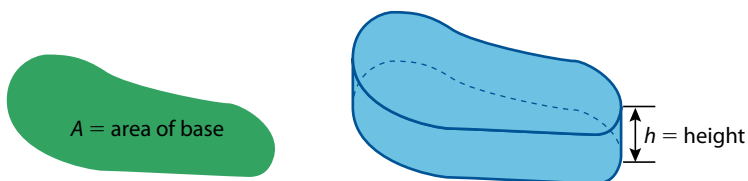

If we call the volume of the slab v_i and the area of its base $A(x)$, then

$$v_i = A(x_i) \cdot h = A(x_i) \cdot \Delta x_i.$$

Using this approximation, the volume of the whole solid can be found by

$$V \approx \sum_{i=1}^n A(x_i) \Delta x_i.$$

Taking the limit as n increases and the widths of the sub-intervals approach zero yields the definite integral:

$$V = \lim_{n \rightarrow \infty} \sum_{i=1}^n A(x_i) \Delta x_i = \int_a^b A(x) dx$$

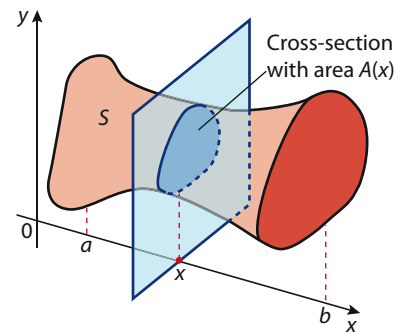
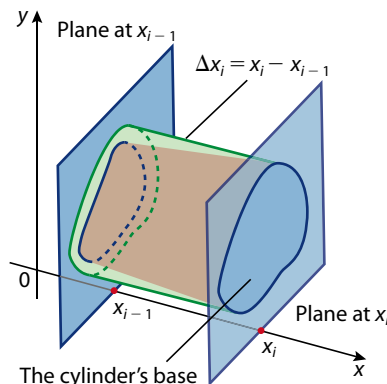
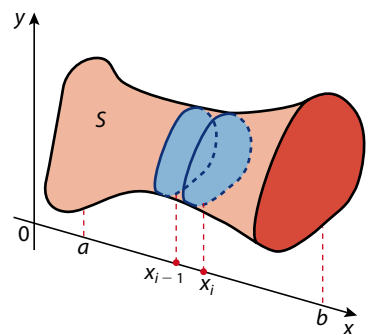

Figure 16.9



• **Hint:** This is an introductory section that will not be examined. It is only used to give you an idea of why we use integrals to find volumes.

Note: If we place the solid along the y -axis and take the cross-sections perpendicular to that axis, we will arrive at a similar expression for the volume of the solid, i.e.

$$V = \lim_{n \rightarrow \infty} \sum_{i=1}^n A(y_i) \Delta y_i = \int_a^b A(y) dy$$

Example 38

Find the volume of the solid formed when the graph of the parabola $y = \sqrt{2x}$ over $[0, 4]$ is rotated around the x -axis through an angle of 2π radians, as shown in the diagram.

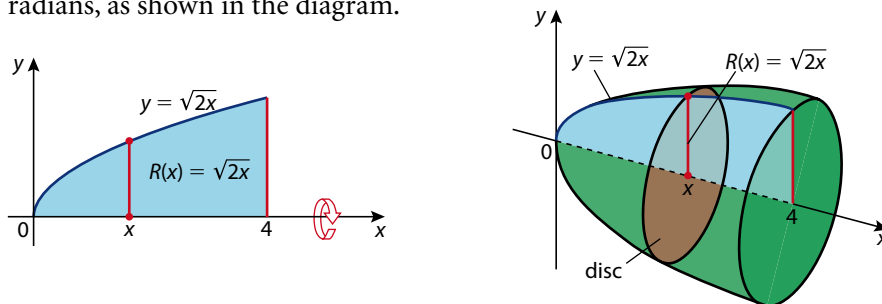

Solution

The cross-section here is a circular disc whose radius is $y = \sqrt{2x}$. Therefore,

$$A(x) = \pi R^2 = \pi(\sqrt{2x})^2 = 2\pi x.$$

The volume is then

$$V = \int_0^4 A(x) dx = \int_0^4 2\pi x dx = \left[2\pi \frac{x^2}{2} \right]_0^4 = 16\pi \text{ cubic units.}$$

Example 38 above is a special case of the general process for finding volumes of the so-called ‘solids of revolution’.

- 1 If a region is bounded by a closed interval $[a, b]$ on the x -axis and a function $f(x)$ is rotated about the x -axis, the volume of the resulting **solid of revolution** is given by

$$V = \int_a^b \pi(f(x))^2 dx.$$

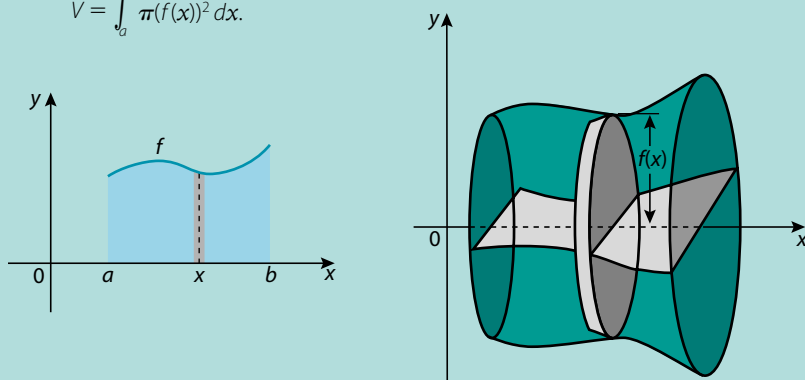

- 2** If the region bounded by a closed interval $[c, d]$ on the y -axis and a function $g(y)$ is rotated about the y -axis, the volume of the resulting solid of revolution is given by

$$V = \int_c^d \pi(g(y))^2 dy.$$

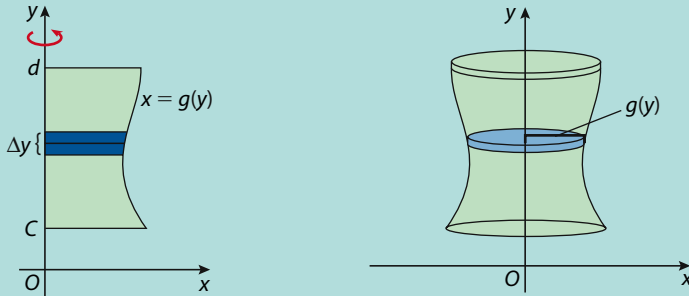

Example 39

Find the volume of a sphere with radius $R = a$.

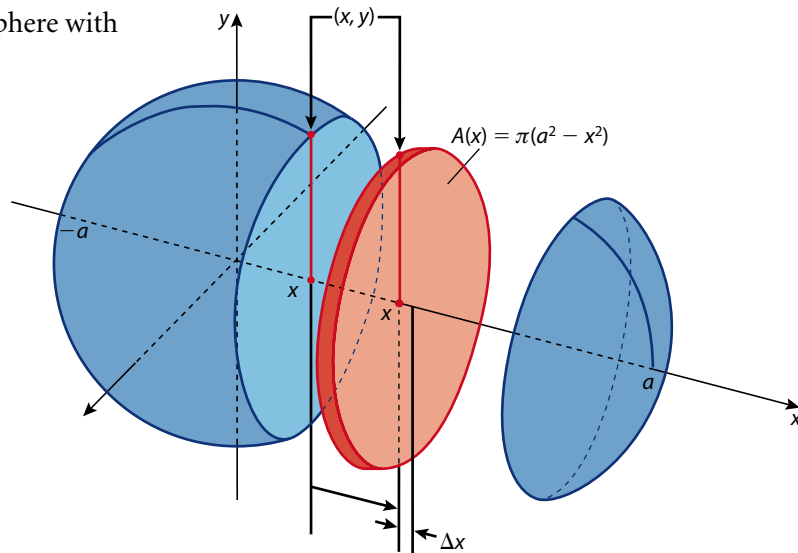

Solution

If we place the sphere with its centre at the origin, the equation of the circle will be

$$x^2 + y^2 = a^2 \Rightarrow y = \pm\sqrt{a^2 - x^2}.$$

The cross-section of the sphere, perpendicular to the x -axis, is a circular disc with radius y , so the area is

$$A(x) = \pi R^2 = \pi y^2 = \pi(\sqrt{a^2 - x^2})^2 = \pi(a^2 - x^2).$$

So, the volume of the sphere is

$$\begin{aligned} V &= \int_{-a}^a \pi(a^2 - x^2) dx = \pi \left[a^2x - \frac{x^3}{3} \right]_{-a}^a \\ &= \pi \left(a^3 - \frac{a^3}{3} \right) - \pi \left(-a^3 + \frac{a^3}{3} \right) \\ &= \pi \left(2a^3 - 2\frac{a^3}{3} \right) = \frac{4\pi a^3}{3}. \end{aligned}$$

Note: If we want to rotate the right-hand region of the circle around the y -axis, then the cross-section of the sphere, perpendicular to the y -axis is a circular disc with radius x . Solving the equation for x instead:

$$x^2 + y^2 = a^2 \Rightarrow x = \pm\sqrt{a^2 - y^2}, \text{ and hence the area is}$$

$$A(y) = \pi R^2 = \pi x^2 = \pi (\sqrt{a^2 - y^2})^2 = \pi(a^2 - y^2),$$

and the volume of the sphere is

$$\begin{aligned} V &= \int_{-a}^a \pi(a^2 - y^2) dy = \pi \left[a^2 y - \frac{y^3}{3} \right]_{-a}^a = \pi \left(a^3 - \frac{a^3}{3} \right) - \pi \left(-a^3 + \frac{a^3}{3} \right) \\ &= \pi \left(2a^3 - 2\frac{a^3}{3} \right) = \frac{4\pi a^3}{3} \end{aligned}$$

This is the same result as above.

Example 40

Find the volume of the solid generated when the region enclosed by $y = \sqrt{3x}$, $x = 3$ and $y = 0$ is revolved about the x -axis.

Solution

$$\begin{aligned} V &= \int_0^3 \pi(f(x))^2 dx \\ &= \pi \int_0^3 (\sqrt{3x})^2 dx \\ &= 3\pi \left[\frac{x^2}{2} \right]_0^3 = \frac{27\pi}{2} \end{aligned}$$

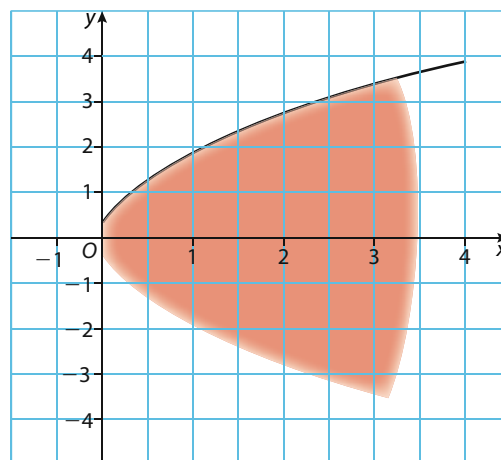

Example 41

Find the volume of the solid generated when the region enclosed by $y = \sqrt{3x}$, $y = 3$ and $x = 0$ is revolved about the y -axis.

Solution

Here, we first find x as a function of y .

$$y = \sqrt{3x} \Rightarrow x = \frac{y^2}{3}, \text{ the interval on the } y\text{-axis is } [0, 3]$$

So, the volume required is

$$V = \int_0^3 \pi \left(\frac{y^2}{3} \right)^2 dy = \frac{\pi}{9} \int_0^3 y^4 dy = \frac{\pi}{9} \left[\frac{y^5}{5} \right]_0^3 = \frac{27\pi}{5}.$$

Washers

Consider the region R between two curves, $y = f(x)$ and $y = g(x)$, and from $x = a$ to $x = b$ where $f(x) > g(x)$. Rotating R about the x -axis generates a solid of revolution S . How do we find the volume of S ?

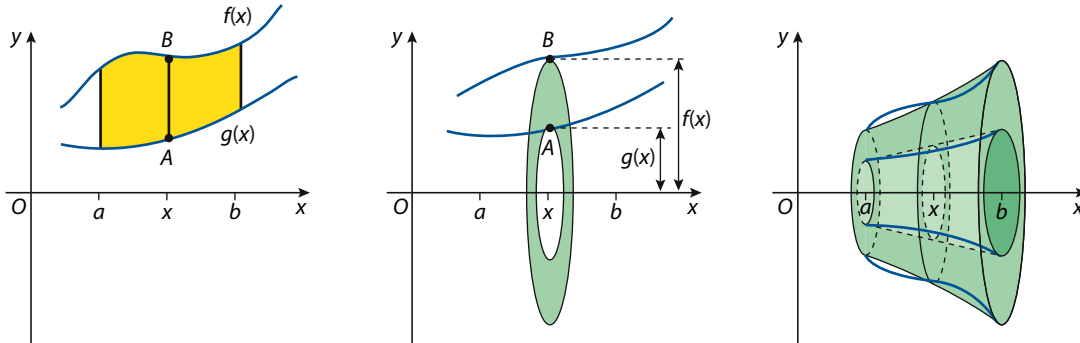

Consider an arbitrary point x in the interval $[a, b]$. The segment AB represents the difference $f(x) - g(x)$. When we rotate this slice, the cross-section perpendicular to the x -axis is going to look like a 'washer' whose area is

$$A = \pi(R^2 - r^2) = \pi((f(x))^2 - (g(x))^2).$$

So, the volume of S is

$$V = \int_a^b A(x) dx = \pi \int_a^b ((f(x))^2 - (g(x))^2) dx.$$

Note: If you are rotating about the y -axis, a similar formula applies.

$$V = \pi \int_c^d ((p(y))^2 - (q(y))^2) dy$$

$$\text{Area} = \pi(R^2 - r^2)$$

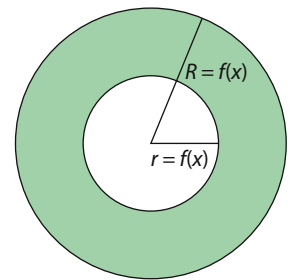

Note: To understand the washer more, you can think of it in the following manner: Let P be the solid generated by rotating the curve $y = f(x)$ and Q be the solid generated by rotating the curve $y = g(x)$. Then S can be found by removing the solid of revolution generated by $y = g(x)$ from the solid of revolution generated by $y = f(x)$, as shown.

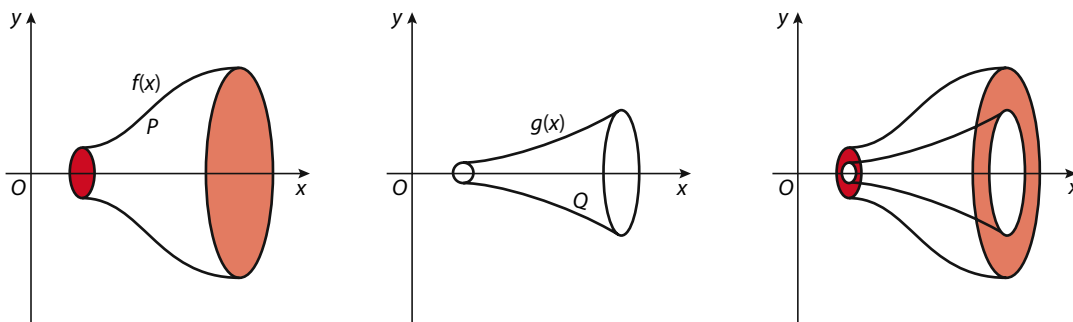

Therefore, volume of $S =$ volume of $P -$ volume of Q . And this justifies the formula:

$$V = \pi \int_a^b (f(x))^2 dx - \pi \int_a^b (g(x))^2 dx = \pi \int_a^b ((f(x))^2 - (g(x))^2) dx$$

Example 42

The region in the first quadrant between $f(x) = 6 - x^2$ and $h(x) = \frac{8}{x^2}$ is rotated about the x -axis. Find the volume of the generated solid.

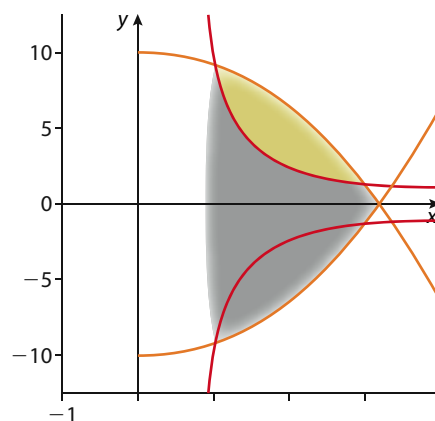
**Solution**

The rotated region is shown in the diagram. $f(x)$ is larger than $h(x)$ in this interval. Moreover, the two curves intersect at:

$$\frac{8}{x^2} = 6 - x^2 \Rightarrow x = \sqrt{2}, x = 2$$

Hence, the volume of the solid of revolution is

$$\begin{aligned} V &= \pi \int_{\sqrt{2}}^2 \left((6 - x^2)^2 - \left(\frac{8}{x^2} \right)^2 \right) dx \\ &= \pi \int_{\sqrt{2}}^2 \left(x^4 - 12x^2 + 36 - \frac{64}{x^4} \right) dx \\ &= \pi \left[\frac{x^5}{5} - 4x^3 + 36x + \frac{64}{3x^3} \right]_{\sqrt{2}}^2 \\ &= \frac{736 - 512\sqrt{2}}{15} \pi. \end{aligned}$$

An alternative method: Volumes by cylindrical shells

Consider the region R under the curve $y = f(x)$. Rotate R about the y -axis. We divide R into vertical strips of width Δx each as shown. When we rotate a strip around the y -axis, we generate a cylindrical shell of Δx thickness and height $f(x)$. To understand how we get the volume, we can cut the shell vertically as shown and 'unfold' it. The resulting rectangular parallelepiped has length $2\pi x$, height $f(x)$ and thickness Δx .

So, the volume of this shell is

$$\begin{aligned} \Delta v_i &= \text{length} \times \text{height} \times \text{thickness} \\ &= (2\pi x) \times f(x) \times \Delta x. \end{aligned}$$

The volume of the whole solid is the sum of the volumes of these shells as the number of shells increases, and consequently

$$\begin{aligned} V &= \lim_{n \rightarrow \infty} \sum_{i=1}^n \Delta v_i = \lim_{\Delta x \rightarrow 0} \sum (2\pi x) \times f(x) \times \Delta x \\ &= 2\pi \int_a^b x f(x) dx. \end{aligned}$$

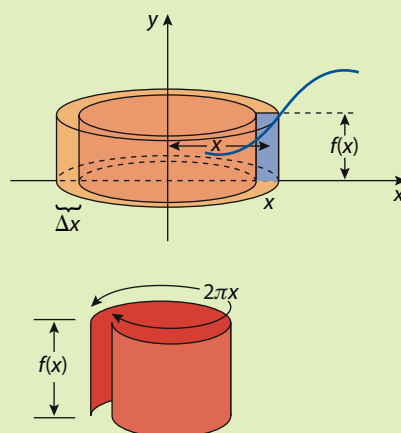
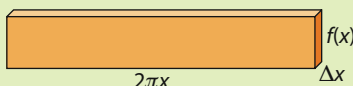

In many problems involving rotation about the y -axis, this would be more accessible than the disc/washer method.

Example 43

Find the volume of the solid generated when we rotate the region under

$$f(x) = \frac{2}{1+x^2}, \quad x=0 \text{ and } x=3 \text{ around the } y\text{-axis.}$$

Solution

Using the shell method, we have

$$\begin{aligned} V &= 2\pi \int_0^3 x \times \frac{2}{1+x^2} dx \\ &= 2\pi \int_0^3 \frac{2x}{1+x^2} dx = 2\pi \int_1^{10} \frac{du}{u} \\ &= 2\pi [\ln u]_1^{10} = 2\pi \ln 10. \end{aligned}$$

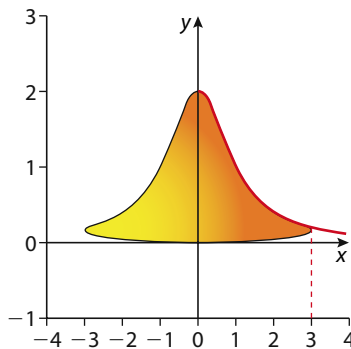

Exercise 16.7

In questions 1–19, find the volume of the solid obtained by rotating the region bounded by the given curves about the x -axis. Sketch the region, the solid and a typical disc.

- 1 $y = 3 - \frac{x}{3}, y = 0, x = 2, x = 3$
 - 2 $y = 2 - x^2, y = 0$
 - 3 $y = \sqrt{16 - x^2}, y = 0, x = 1, x = 3$
 - 4 $y = \frac{3}{x}, y = 0, x = 1, x = 3$
 - 5 $y = 3 - x, y = 0, x = 0$
 - 6 $y = \sqrt{\sin x}, y = 0, 0 \leq x \leq \pi$
 - 7 $y = \sqrt{\cos x}, y = 0, -\frac{\pi}{2} \leq x \leq \frac{\pi}{3}$
 - 8 $y = 4 - x^2, y = 0$
 - 9 $y = x^3 + 2x + 1, y = 0, x = 1$
 - 10 $y = -4x - x^2, y = x^2$
 - 11 $y = \sec x, x = \frac{\pi}{4}, x = \frac{\pi}{3}, y = 0$
 - 12 $y = 1 - x^2, y = x^3 + 1$
 - 13 $y = \sqrt{36 - x^2}, y = 4$
 - 14 $x = \sqrt{y}, y = 2x$
 - 15 $y = \sin x, y = \cos x, x = \frac{\pi}{4}, x = \frac{\pi}{2}$
 - 16 $y = 2x^2 + 4, y = x, x = 1, x = 3$
 - 17 $y = \sqrt{x^4 + 1}, y = 0, x = 1, x = 3$
 - 18 $y = 16 - x, y = 3x + 12, x = -1$
 - 19 $y = \frac{1}{x}, y = \frac{5}{2} - x$
- 20 Find the volume resulting from a rotation of this region about
- a) the x -axis
 - b) the y -axis.

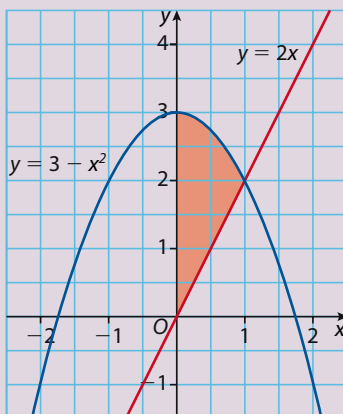

In questions 21–31, find the volume of the solid obtained by rotating the region bounded by the given curves about the y -axis. Sketch the region, the solid and a typical disc/shell.

$$21 \quad y = x^2, y = 0, x = 1, x = 3$$

$$22 \quad y = x, y = \sqrt{9 - x^2}, x = 0$$

$$23 \quad y = x^3 - 4x^2 + 4x, y = 0$$

$$24 \quad y = \sqrt{3x}, x = 5, x = 11, y = 0$$

$$25 \quad y = x^2, y = \frac{2}{1 + x^2}$$

$$26 \quad y = \sqrt{x^2 + 2}, x = 3, y = 0, x = 0$$

$$27 \quad y = \frac{7x}{\sqrt{x^3 + 7}}, x = 3, y = 0$$

$$28 \quad y = \sin x, y = \cos x, x = \frac{\pi}{4}, x = \frac{\pi}{2}$$

$$29 \quad y = 2x^2 + 4, y = x, x = 1, x = 3$$

$$30 \quad y = \sin(x^2), y = 0, x = 0, x = \sqrt{\pi}$$

$$31 \quad y = 5 - x^3, y = 5 - 4x$$

16.8 Modelling linear motion

In previous sections of this text, we have examined problems involving displacement, velocity and acceleration of a moving object. In different sections of Chapter 13, we applied the fact that a derivative is a rate of change to express velocity and acceleration as derivatives. Even though our earlier work on motion problems involved an object moving in one, two or even three dimensions, our mathematical models considered the object's motion occurring only along a straight line. For example, projectile motion (e.g. a ball being thrown) is often modelled by a position function that simply gives the height (displacement) of the object. In that way, we are modelling the motion as if it were restricted to a vertical line.

In this section, we will again analyze the motion of an object as if its motion takes place along a straight line in space. This can only make sense if the mass (and thus, size) of the object is not taken into account. Hence, the object is modelled by a particle whose mass is considered to be zero. This study of motion, without reference either to the forces that cause it or to the mass of the object, is known as **kinematics**.

Displacement and total distance travelled

Recall from Chapter 13 that given time t , displacement s , velocity v and acceleration a , we have the following:

$$v = \frac{ds}{dt}, \quad a = \frac{dv}{dt}, \quad \text{and} \quad a = \frac{d}{dt} \left(\frac{ds}{dt} \right) = \frac{d^2s}{dt^2}$$

Let's review some of the essential terms we use to describe an object's motion.

Position, distance and displacement

- The **position** s of a particle, with respect to a chosen axis, is a measure of how far it is from a fixed point (usually the origin) *and* of its direction relative to the fixed point.
- The **distance** $|s|$ of a particle is a measure of how far it is from a fixed point (usually the origin) and does *not* indicate direction. Thus, distance is the magnitude of position and is always positive.
- The **displacement** is the *change* in position. The displacement of an object may be positive, negative or zero, depending on its motion.

It is important to understand the difference between displacement and distance travelled. Consider a couple of simple examples of an object moving along the x -axis.

1. In this first example, assume that the object does not change direction during the interval $0 \leq t \leq 5$. In other words, its velocity does not change from positive to negative or from negative to positive. If the position of the object at $t = 0$ is $x = 2$ and then the object moves so that at $t = 5$ its position is $x = -3$, its displacement, or change in position, is -5 because the object changed its position by 5 units in the negative direction. This can be calculated by (final position) $-$ (initial position) $= -3 - 2 = -5$. However, the distance travelled would be the absolute value of displacement, calculated by $|\text{final position} - \text{initial position}| = |-3 - 2| = +5$.

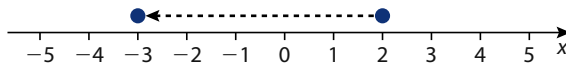

2. In this example, the object's initial and final positions are the same as in the first example – that is, at $t = 0$ its position is $x = 2$ and at $t = 5$ its position is $x = -3$. However, the object changed direction in that it first travelled to the left (negative velocity) from $x = 2$ to $x = -5$ during the interval $0 \leq t \leq 3$, and then travelled to the right (positive velocity) from $x = -5$ to $x = -3$. The object's displacement is -5 – the same as in the first example because its net change in position is just the difference between final and initial positions. However, it's clear that the object has travelled further than in the first example. But we cannot calculate it in the same way as we did in the first example. We will have to make a separate calculation for each interval where the direction changed. Hence, total distance travelled $= |-5 - 2| + |-3 - (-5)| = 7 + 2 = 9$.

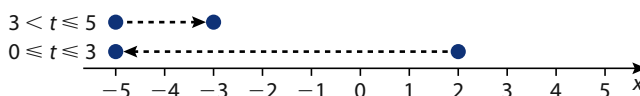

There is no separate word to describe the magnitude of acceleration, $|a|$.



The definite integral is a mathematical tool that can be used in applications to calculate net change of a quantity (e.g. Δ position \rightarrow displacement) and total accumulation (e.g. Σ area \rightarrow volume).



Velocity and speed

- The **velocity** $v = \frac{ds}{dt}$ of a particle is a measure of how fast it is moving *and* of its direction of motion relative to a fixed point.
- The **speed** $|v|$ of a particle is a measure of how fast it is moving and does *not* indicate direction. Thus, speed is the magnitude of velocity and is always positive.

Acceleration

- The **acceleration** $a = \frac{dv}{dt}$ of a particle is a measure of how fast its velocity is changing.

Example 44

The displacement s of a particle on the x -axis, relative to the origin, is given by the position function $s(t) = -t^2 + 6t$, where s is in centimetres and t is in seconds.

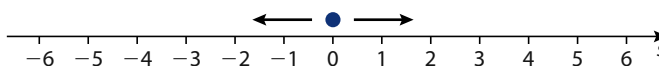

- Find a function for the particle's velocity $v(t)$ in terms of t . Graph the functions $s(t)$ and $v(t)$ on separate axes.
- Find the particle's position at the following times: $t = 0, 1, 3$ and 6 seconds.
- Find the particle's displacement for the following intervals: $0 \leq t \leq 1$, $1 \leq t \leq 3$, $3 \leq t \leq 6$ and $0 \leq t \leq 6$.
- Find the particle's total distance travelled for the following intervals: $0 \leq t \leq 1$, $1 \leq t \leq 3$, $3 \leq t \leq 6$ and $0 \leq t \leq 6$.

Solution

Position function: $s(t) = -t^2 + 6t$

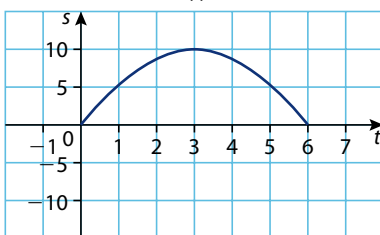

Velocity function: $v(t) = s'(t) = -2t + 6$

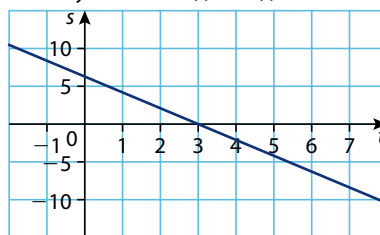

- $v(t) = \frac{d}{dt}(-t^2 + 6t) = -2t + 6$
- The particle's position at:
 - $t = 0$ is $s(0) = -(0)^2 + 6(0) = 0$ cm
 - $t = 1$ is $s(1) = -(1)^2 + 6(1) = 5$ cm
 - $t = 3$ is $s(3) = -(3)^2 + 6(3) = 9$ cm
 - $t = 6$ is $s(6) = -(6)^2 + 6(6) = 0$ cm
- The particle's displacement for the interval:
 - $0 \leq t \leq 1$ is Δ position = $s(1) - s(0) = 5 - 0 = 5$ cm
 - $1 \leq t \leq 3$ is Δ position = $s(3) - s(1) = 9 - 5 = 4$ cm
 - $3 \leq t \leq 6$ is Δ position = $s(6) - s(3) = 0 - 9 = -9$ cm
 - $0 \leq t \leq 6$ is Δ position = $s(6) - s(0) = 0 - 0 = 0$ cm

This last result makes sense considering the particle moved to the right 9 cm then at $t = 3$ turned around and moved to the left 9 cm, ending where it started – thus, no change in net position.

d) The particle's total distance travelled for the interval:

- $0 \leq t \leq 1$ is $|s(1) - s(0)| = |5 - 0| = 5$ cm
- $1 \leq t \leq 3$ is $|s(3) - s(1)| = |9 - 5| = 4$ cm
- $3 \leq t \leq 6$ is $|s(6) - s(3)| = |0 - 9| = |-9| = 9$ cm
- $0 \leq t \leq 6$: The object's motion changed direction (velocity = 0) at $t = 3$, so total distance is $|s(3) - s(0)| + |s(6) - s(3)|$
 $= |9 - 0| + |0 - 9| = 9 + 9 = 18$ cm

Since differentiation of the position function gives the velocity function (i.e. $v = \frac{ds}{dt}$), we expect that the inverse of differentiation, integration, will lead us in the reverse direction – that is, from velocity to position. When velocity is constant, we can find the displacement with the formula:

$$\text{displacement} = \text{velocity} \times \Delta \text{ in time}$$

If we drove a car at a constant velocity of 50 km/h for 3 hours, our displacement (same as distance travelled in this case) is 150 km. If a particle travelled to the left on the x -axis at a constant rate of -4 units/sec for 5 seconds, the particle's displacement is -20 units.

The velocity–time graph below depicts an object's motion with a constant velocity of 5 cm/s for $0 \leq t \leq 3$. Clearly, the object's displacement is $5 \text{ cm/s} \times 3 \text{ sec} = 15 \text{ cm}$ for this interval.

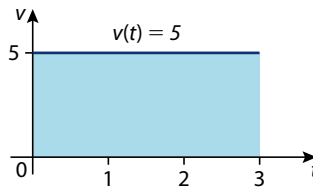
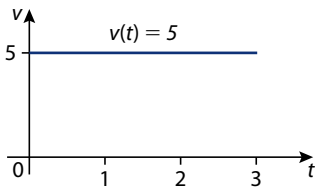

The rectangular area ($3 \times 5 = 15$) under the velocity curve is equal to the object's displacement.

Looking back at Example 44, consider the area under the graph of $v(t)$ from $t = 0$ to $t = 3$.

Velocity function: $v(t) = s'(t) = -2t + 6$

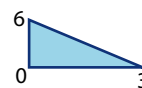
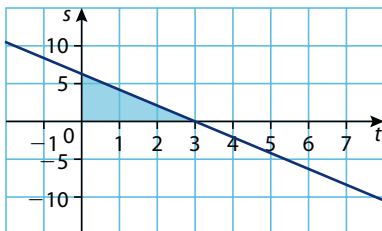

$$\text{Area} = \frac{1}{2} \times 3 \times 6 = 9$$

Given the discussion above, we should not be surprised to see that the area under the velocity curve for a certain interval is equal to the displacement

for that interval. We can argue that just as the total area can be found by summing the areas of narrow rectangular strips, the displacement can be found by summing small displacements ($v \cdot \Delta t$). Consider:

$$\text{displacement} = \text{velocity} \times \Delta \text{ in time} \Rightarrow s = v \cdot \Delta t \Rightarrow s = v \cdot dt$$

We learned earlier in this chapter that if $f(x) \geq 0$ then the definite integral

$\int_a^b f(x) dx$ gives the area between $y = f(x)$ and the x -axis from $x = a$ to $x = b$. And if $f(x) \leq 0$ then $\int_a^b f(x) dx$ gives a number that is the opposite of the area between $y = f(x)$ and the x -axis from a to b .

Using integration to find displacement and total distance travelled

Given that $v(t)$ is the velocity function for a particle moving along a line, then:

$\int_a^b v(t) dt$ gives the displacement from $t = a$ to $t = b$.

$\left| \int_a^b v(t) dt \right|$ gives the total distance travelled from $t = a$ to $t = b$ if the particle does not change direction during the interval $a < t < b$.

If a particle changes direction at some $t = c$ for $a < c < b$, the total distance

travelled for the particle is given by $\left| \int_a^c v(t) dt \right| + \left| \int_c^b v(t) dt \right|$.

In general, the total distance travelled by an object from time t_0 to t_1 , with many switches in direction is given by $\int_{t_0}^{t_1} |v(t)| dt$.

Let's apply integration to find the displacement and distance travelled for the two intervals $3 \leq t \leq 6$ and $0 \leq t \leq 6$ in Example 40.

- For $3 \leq t \leq 6$:

$$\begin{aligned} \text{Displacement} &= \int_3^6 (-2t + 6) dt = \left[-t^2 + 6t \right]_3^6 \\ &= [-(6)^2 + 6(6)] - [-(3)^2 + 6(3)] = 0 - 9 = -9 \end{aligned}$$

$$\begin{aligned} \text{Distance travelled} &= \left| \int_3^6 (-2t + 6) dt \right| = \left| \left[-t^2 + 6t \right]_3^6 \right| \\ &= |[-(6)^2 + 6(6)] - [-(3)^2 + 6(3)]| = |0 - 9| = 9 \end{aligned}$$

- For $0 \leq t \leq 6$:

$$\begin{aligned} \text{Displacement} &= \int_0^6 (-2t + 6) dt = \left[-t^2 + 6t \right]_0^6 \\ &= [-(6)^2 + 6(6)] - [0] = 0 \end{aligned}$$

$$\begin{aligned} \text{Distance travelled} &= \left| \int_0^3 (-2t + 6) dt \right| + \left| \int_3^6 (-2t + 6) dt \right| \\ &\quad \text{Particle changed direction at } t = 3. \end{aligned}$$

$$\begin{aligned} &= \left| \left[-t^2 + 6t \right]_0^3 \right| + \left| \left[-t^2 + 6t \right]_3^6 \right| \\ &= |(-9 + 18) - 0| + |0 - (-9 + 18)| \\ &= |9| + |-9| = 9 + 9 = 18 \end{aligned}$$

Example 45

The function $v(t) = \sin(\pi t)$ gives the velocity in m/s of a particle moving along the x -axis.

- Determine when the particle is moving to the right, to the left, and stopped. At any time it stops, determine if it changes direction at that time.
- Find the particle's displacement for the time interval $0 \leq t \leq 3$.
- Find the particle's total distance travelled for the time interval $0 \leq t \leq 3$.

Solution

- a) $v(t) = \sin(\pi t) = 0 \Rightarrow \sin(k \cdot \pi) = 0$ for $k \in \mathbb{Z} \Rightarrow \pi t = k\pi \Rightarrow t = k$, $k \in \mathbb{Z}$ for $0 \leq t \leq 3$, $t = 0, 1, 2, 3$. Therefore, the particle is stopped at $t = 0, 1, 2, 3$.

Since $t = 0$ and $t = 3$ are endpoints of the interval, the particle can only change direction at $t = 1$ or $t = 2$.

$$v\left(\frac{1}{2}\right) = \sin\left(\pi \cdot \frac{1}{2}\right) = 1; v\left(\frac{3}{2}\right) = \sin\left(\pi \cdot \frac{3}{2}\right) = -1 \Rightarrow \text{direction changes at } t = 1$$

$$v\left(\frac{3}{2}\right) = \sin\left(\pi \cdot \frac{3}{2}\right) = -1; v\left(\frac{5}{2}\right) = \sin\left(\pi \cdot \frac{5}{2}\right) = 1 \Rightarrow \text{direction changes again at } t = 2$$

- b) Displacement $= \int_0^3 \sin(\pi t) dt = \left[-\frac{1}{\pi} \cos(\pi t)\right]_0^3$
 $= -\frac{1}{\pi} \cos(3\pi) - \left(-\frac{1}{\pi} \cos(0)\right) = -\frac{1}{\pi}(-1) + \frac{1}{\pi}(1) = \frac{2}{\pi} \approx 0.637$ metres

- c) Total distance travelled $= \left| \int_0^1 \sin(\pi t) dt \right| + \left| \int_1^2 \sin(\pi t) dt \right|$
 $+ \left| \int_2^3 \sin(\pi t) dt \right| = \left| \left[-\frac{1}{\pi} \cos(\pi t)\right]_0^1 \right|$
 $+ \left| \left[-\frac{1}{\pi} \cos(\pi t)\right]_1^2 \right| + \left| \left[-\frac{1}{\pi} \cos(\pi t)\right]_2^3 \right|$
 $= \left| \frac{2}{\pi} \right| + \left| -\frac{2}{\pi} \right| + \left| \frac{2}{\pi} \right| = \frac{6}{\pi} \approx 1.91$ metres

Note that, in Example 45, the position function is not known precisely. The position function can be obtained by finding the anti-derivative of the velocity function.

$$s(t) = \int v(t) dt = \int \sin(\pi t) dt = -\frac{1}{\pi} \cos(\pi t) + C$$

We can only determine the constant of integration C if we know the particle's initial position (or position at any other specific time). However, the particle's initial position will not affect displacement or distance travelled for any interval.

Position and velocity from acceleration

If we can obtain position from velocity by applying integration then we can also obtain velocity from acceleration by integrating. Consider the following example.



Example 46

The motion of a falling parachutist is modelled as linear motion by considering that the parachutist is a particle moving along a line whose positive direction is vertically downwards. The parachute is opened at $t = 0$ at which time the parachutist's position is $s = 0$. According to the model, the acceleration function for the parachutist's motion for $t > 0$ is given by:

$$a(t) = -54e^{-1.5t}$$

- At the moment the parachute opens, the parachutist has a velocity of 42 m/s. Find the velocity function of the parachutist for $t > 0$. What does the model say about the parachutist's velocity as $t \rightarrow \infty$?
- Find the position function of the parachutist for $t > 0$.

Solution

$$\begin{aligned} \text{a) } v(t) &= \int a(t) dt = \int (-54e^{-1.5t}) dt \\ &= -54 \left(\frac{1}{-1.5} \right) e^{-1.5t} + C \\ &= 36e^{-1.5t} + C \end{aligned}$$

$$\text{Since } v = 42 \text{ when } t = 0, \text{ then } 42 = 36e^0 + C \Rightarrow 42 = 36 + C \Rightarrow C = 6$$

Therefore, after the parachute opens ($t > 0$) the velocity function is $v(t) = 36e^{-1.5t} + 6$.

$$\text{Since } \lim_{t \rightarrow \infty} e^{-1.5t} = \lim_{t \rightarrow \infty} \frac{1}{e^{1.5t}} = 0, \text{ then as } t \rightarrow \infty, \lim_{t \rightarrow \infty} v(t) = 6 \text{ m/sec.}$$

$$\begin{aligned} \text{b) } s(t) &= \int v(t) dt = \int (36e^{-1.5t} + 6) dt \\ &= 36 \left(\frac{1}{-1.5} \right) e^{-1.5t} + 6t + C \\ &= -24e^{-1.5t} + 6t + C \end{aligned}$$

$$\begin{aligned} \text{Since } s = 0 \text{ when } t = 0, \text{ then } 0 &= -24e^0 + 6(0) + C \\ \Rightarrow 0 &= -24 + C \Rightarrow C = 24 \end{aligned}$$

Therefore, after the parachute opens ($t > 0$) the position function is $s(t) = -24e^{-1.5t} + 6t + 24$.

The limit of the velocity as $t \rightarrow \infty$, for a falling object, is called the **terminal velocity** of the object. While the limit $t \rightarrow \infty$ is never attained (the parachutist eventually lands on the ground), the velocity gets close to the terminal velocity very quickly. For example, after just 8 seconds, the velocity is $v(8) = 36e^{-1.5(8)} + 6 \approx 6.0002$ m/s.



Uniformly accelerated motion

Motion under the effect of gravity in the vicinity of Earth (or other planets) is an important case of rectilinear motion. This is called uniformly accelerated motion.

If a particle moves with constant acceleration along the s -axis, and if we know the initial speed and position of the particle, then it is possible to have specific formulae for the position and speed at any time t . This is how:

Assume acceleration is constant, i.e. $a(t) = a$, $v(0) = v_0$ and $s(0) = s_0$.

$$v(t) = \int a dt = at + c, \text{ we know that } v(0) = v_0, \text{ then}$$

$$v(0) = v_0 = a(0) + c \Rightarrow c = v_0; \text{ hence } v(t) = at + v_0$$

$$s(t) = \int v(t) dt = \int (at + v_0) dt = \frac{1}{2}at^2 + v_0t + c, \text{ but } s(0) = s_0, \text{ then}$$

$$s(0) = s_0 = \frac{1}{2}a(0^2) + v_0(0) + c \Rightarrow c = s_0; \text{ hence}$$

$$s(t) = \frac{1}{2}at^2 + v_0t + s_0$$

When this is applied to a free-fall model (s -axis vertical), then

$$v(t) = -gt + v_0, \text{ and}$$

$$s(t) = -\frac{1}{2}gt^2 + v_0t + s_0, \text{ where } g = 9.8 \text{ m/s}^2.$$

Example 47

A ball is hit, from a point 2 m above the ground, directly upward with initial velocity of 45 m/s. How high will the ball travel?

Solution

$$v(t) = -9.8t + 45$$

$$s(t) = -\frac{1}{2}(9.8)t^2 + 45t + 2 = -4.9t^2 + 45t + 2$$

The ball will rise till $v(t) = 0$, $\Rightarrow 0 = -9.8t + 45$, $\Rightarrow t \approx 4.6$ s

At this time,

$$s(4.6) = -4.9(4.6)^2 + 45(4.6) + 2 \approx 105.32\text{m}.$$

Example 48

Tim is running at a constant speed of 5 m/s to catch a bus that stopped at the station. The bus started as it was 11 m away with an acceleration of 1 m/s^2 . How long will it take Tim to catch up with the bus?

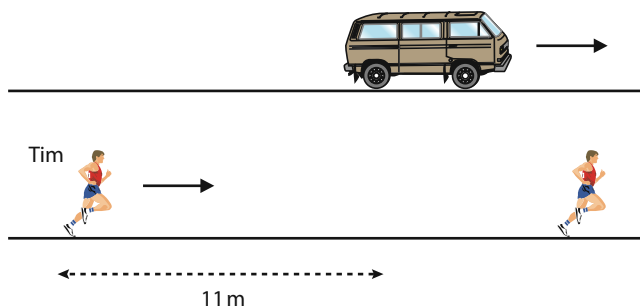

Solution

To catch the bus at some time t , Tim will have to cover a distance s_T that is equal to 11 m plus s_b travelled by the bus.

$$s_T = 5t$$

$$s_b = \frac{1}{2}t^2$$

But $s_T = s_b + 11 = \frac{1}{2}t^2 + 11$, therefore

$$5t = \frac{1}{2}t^2 + 11 \Rightarrow t^2 - 10t + 22 = 0$$

So, $t \approx 3.3$ s, or $t \approx 6.7$ s.

Note: The reason we have two answers is that since Tim is travelling at a constant rate he may miss the door at first, and if he continues, the bus will catch up with him 6.7 s later!

Exercise 16.8

In questions 1–6, the velocity of a particle along a rectilinear path is given by the equation $v(t)$ in m/s. Find both the net distance and the total distance it travels between the times $t = a$ and $t = b$.

1 $v(t) = t^2 - 11t + 24, a = 0, b = 10$

2 $v(t) = t - \frac{1}{t^2}, a = 0.1, b = 1$

3 $v(t) = \sin 2t, a = 0, b = \frac{\pi}{2}$

4 $v(t) = \sin t + \cos t, a = 0, b = \pi$

5 $v(t) = t^3 - 8t^2 + 15t, a = 0, b = 6$

6 $v(t) = \sin\left(\frac{\pi t}{2}\right) + \cos\left(\frac{\pi t}{2}\right), a = 0, b = 1$

In questions 7–11, the acceleration of a particle along a rectilinear path is given by the equation $a(t)$ in m/s^2 , and the initial velocity v_0 m/s is also given. Find the velocity of the particle as a function of t , and both the net distance and the total distance it travels between the times $t = a$ and $t = b$.

7 $a(t) = 3, v_0 = 0, a = 0, b = 2$

8 $a(t) = 2t - 4, v_0 = 3, a = 0, b = 3$

9 $a(t) = \sin t, v_0 = 0, a = 0, b = \frac{3\pi}{2}$

10 $a(t) = \frac{-1}{\sqrt{t+1}}, v_0 = 2, a = 0, b = 4$

11 $a(t) = 6t - \frac{1}{(t+1)^3}, v_0 = 2, a = 0, b = 2$

In each question 12–15, the velocity and initial position of an object moving along a coordinate line are given. Find the position of the object at time t .

12 $v = 9.8t + 5, s(0) = 10$

13 $v = 32t - 2, s(0.5) = 4$

14 $v = \sin \pi t, s(0) = 0$

15 $v = \frac{1}{t+2}, t > -2, s(-1) = \frac{1}{2}$

In each question 16–19, the acceleration is given as well as the initial velocity and initial position of an object moving on a coordinate line. Find the position of the object at time t .

16 $a = e^t, v(0) = 20, s(0) = 5$

17 $a = 9.8, v(0) = -3, s(0) = 0$

18 $a = -4 \sin 2t, v(0) = 2, s(0) = -3$

19 $a = \frac{9}{\pi^2} \cos \frac{3t}{\pi}, v(0) = 0, s(0) = -1$

In questions 20–23, an object moves with a speed of $v(t)$ m/s along the s -axis. Find the displacement and the distance travelled by the object during the given time interval.

20 $v(t) = 2t - 4; 0 \leq t \leq 6$

21 $v(t) = |t - 3|; 0 \leq t \leq 5$

22 $v(t) = t^3 - 3t^2 + 2t; 0 \leq t \leq 3$

23 $v(t) = \sqrt{t} - 2; 0 \leq t \leq 3$

In questions 24–26, an object moves with an acceleration $a(t)$ m/s² along the s -axis. Find the displacement and the distance travelled by the object during the given time interval.

24 $a(t) = t - 2, v_0 = 0, 1 \leq t \leq 5$

25 $a(t) = \frac{1}{\sqrt{5t+1}}, v_0 = 2, 0 \leq t \leq 3$

26 $a(t) = -2, v_0 = 3, 1 \leq t \leq 4$

27 The velocity of an object moving along the s -axis is

$$v = 9.8t - 3.$$

- Find the object's displacement between $t = 1$ and $t = 3$ given that $s(0) = 5$.
- Find the object's displacement between $t = 1$ and $t = 3$ given that $s(0) = -2$.
- Find the object's displacement between $t = 1$ and $t = 3$ given that $s(0) = s_0$.

28 The displacement s metres of a moving object from a fixed point O at time t seconds is given by $s(t) = 50t - 10t^2 + 1000$.

- Find the velocity of the object in m s⁻¹.
- Find its maximum displacement from O.

29 A particle moves along a line so that its speed v at time t is given by

$$v(t) = \begin{cases} 5t, & 0 \leq t < 1 \\ 6\sqrt{t} - \frac{1}{t}, & t \geq 1 \end{cases}$$

where t is in seconds and v is in cm/s. Estimate the time(s) at which the particle is 4 cm from its starting position.

30 A projectile is fired vertically upward with an initial velocity of 49 m/s from a platform 150 m high.

- How long will it take the projectile to reach its maximum height?
- What is the maximum height?
- How long will it take the projectile to pass its starting point on the way down?
- What is the velocity when it passes the starting point on the way down?
- How long will it take the projectile to hit the ground?
- What will its speed be at impact?

16.9 Differential equations (Optional)

This section presents only an introduction to differential equations. More on differential equations can be found in the Options part: Calculus.

A differential equation is an equation that relates an unknown function and one or more of its derivatives. A *first-order* differential equation is an equation that involves an unknown function and its *first derivative*. Examples of first-order differential equations are:

$$y' + 2xy = \sin x, \quad \frac{dy}{dx} = y + 2x, \quad \text{and} \quad \frac{dy}{dx} = -ky$$

In this part of the textbook we will consider only first-order differential equations that can be written in the form

$$\frac{dy}{dx} = f(x, y).$$

Here $f(x, y)$ is a function of two variables defined on a *region* in the xy -plane. By a solution to the differential equation, we mean the following.

Solution of a differential equation

We say that a *differentiable* function $y = y(x)$ is a solution to the differential equation

$$\frac{dy}{dx} = f(x, y)$$

on an interval of x -values (sometimes \mathbb{R}) when

$$\frac{d}{dx}y(x) = f(x, y(x)).$$

The initial condition $y(x_0) = y_0$ amounts to requiring the solution curve $y = y(x)$ to pass through the point (x_0, y_0) .

Let us clarify these initial ideas by some examples.

Note: In algebra we usually seek the unknown variable values that satisfy an equation such as $3x^2 - 2x - 5 = 0$. By contrast, in solving a differential equation, we are looking for the unknown functions $y = y(x)$ for which an identity such as $y'(x) = 3x^2y(x)$ holds on some interval of real numbers. Usually, we will desire to find all solutions of the differential equation, if achievable.

Example 49

Verify that $y(x) = Ce^{x^3}$ is a solution to the differential equation

$$\frac{dy}{dx} = 3x^2y.$$

By $y(x)$, we mean 'y of x', i.e. y as a function of x, and not 'y times x'.



Solution

Since C is a constant in $y(x) = Ce^{x^3}$, then

$$\frac{dy}{dx} = C(3x^2e^{x^3}) = 3x^2(Ce^{x^3}) = 3x^2y.$$

Consequently every function $y(x)$ of the form $y(x) = Ce^{x^3}$ satisfies – and thus is a solution of – the differential equation

$$\frac{dy}{dx} = 3x^2y$$

for all real x . In fact $y(x) = Ce^{x^3}$ defines an infinite family of different solutions to this differential equation, one for each choice of the arbitrary constant C .

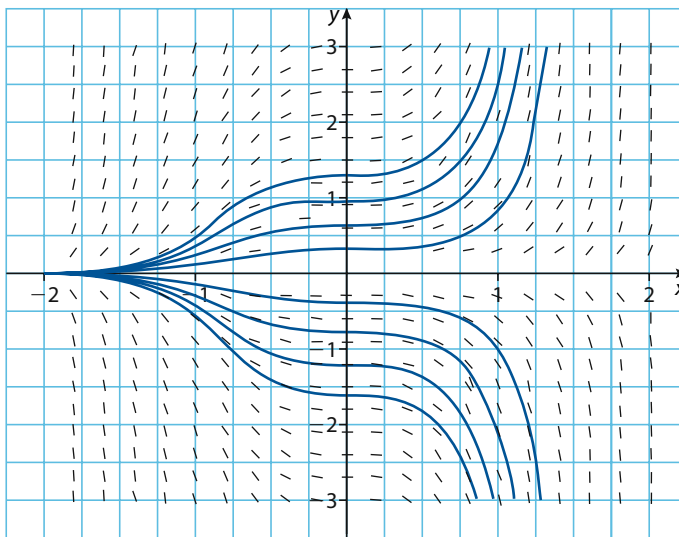
**Example 50**

Verify that

$$y(x) = -\frac{1}{2x^4 + 3}$$

is a solution to the differential equation

$$\frac{dy}{dx} = 8x^3y^2$$

over the interval $]-\infty, \infty[$.

Solution

Notice that the denominator in $y(x)$ is never zero and that $y(x)$ is differentiable everywhere. Furthermore, for all real numbers x ,

$$\begin{aligned} \frac{d}{dx} y(x) &= \frac{d}{dx} \left(-\frac{1}{2x^4 + 3} \right) = \frac{8x^3}{(2x^4 + 3)^2} \\ &= 8x^3 \left(-\frac{1}{2x^4 + 3} \right)^2 = 8x^3y^2 \end{aligned}$$

Thus,

$$y(x) = -\frac{1}{2x^4 + 3}$$

is a solution to the given differential equation.

Differential equations as mathematical models

The following examples illustrate typical cases where scientific principles are translated into differential equations.

- Newton's law of cooling** states that the rate of change of the temperature T of an object is proportional to the difference between T and the temperature of the surrounding medium S .

That is,

$$\frac{dT}{dt} = k(T - S)$$

where k is a constant and S is usually considered constant.

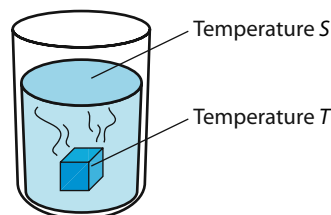

- Population growth rate** in cases where the birth and death rates are not variable is proportional to the size of the population. That is,

$$\frac{dP}{dt} = kP$$

where k is a constant.

Shortly, we will learn how to solve such problems.

Separable differential equations

In this section, we will limit our discussion to one basic type, the **separable differential equations**, also called **variables-separable differential equations**.

The first-order differential equation

$$\frac{dy}{dx} = f(x, y)$$

is called variable separable when the function $f(x, y)$ can be factored into a product or quotient of two functions such as

$$\frac{dy}{dx} = g(x)h(y) \text{ or } \frac{dy}{dx} = \frac{p(x)}{q(y)}.$$

In such cases, the variables x and y can be separated by writing

$$\frac{dy}{h(y)} = g(x)dx \text{ or } q(y)dy = p(x)dx$$

and then simply integrating both sides with respect to x . That is,

$$\int \frac{dy}{h(y)} = \int g(x)dx + c \text{ or } \int q(y)dy = \int p(x)dx + c.$$

Note: You need to remember that $h(y)$ is a continuous function of y alone and $g(x)$ is a continuous function of x alone. The same goes for $q(y)$ and $p(x)$.

Note: We also may say that the method of solution is separation of variables.

Here are some examples of differential equations that are separable

Original differential equation	Rewritten with variables separated
$(x^2 + 4)y' = 3xy$	$\frac{dy}{y} = \frac{3x}{x^2 + 4}dx$
$\frac{3xe^y y'}{1 + e^{2y}} = 5$	$\frac{3e^y}{1 + e^{2y}}dy = \frac{5}{x}dx$
$\frac{dy}{dx} = xy + 4$	Not separable!
$3x^2 + y\frac{dy}{dx} = 7$	$ydy = (7 - 3x^2)dx$
$x^2\frac{dy}{dx} + y^2 = xy^2$	$\frac{1}{y^2}dy = \frac{(x - 1)}{x^2}dx$
$y^2\frac{dy}{dx} + x^2 = xy^2$	Not separable!

We will end this section by looking at a few examples.

Example 51

Solve

$$y' - 9x^2y^2 = 5y^2.$$

Solution

We first factor the equation to separate the variables.

$$\begin{aligned} \frac{dy}{dx} = 5y^2 + 9x^2y^2 &\Rightarrow \frac{dy}{dx} = y^2(5 + 9x^2) \\ &\Rightarrow \frac{dy}{y^2} = (5 + 9x^2)dx \\ &\Rightarrow -\frac{1}{y} = 5x + 3x^3 + c \\ &\Rightarrow y = \frac{-1}{5x + 3x^3 + c} \end{aligned}$$

This is a general solution for the differential equation. In this case we are able to express this function in explicit form.

Example 52

Solve

$$\frac{dy}{dx} = \frac{3x^2y}{1 + 4y^2}.$$

Solution

With very few steps, we can separate the variables:

$$\frac{1 + 4y^2}{y} = 3x^2 dx$$

And now we can integrate both sides:

$$\int \frac{1 + 4y^2}{y} dy = \int 3x^2 dx \Leftrightarrow \int \left(\frac{1}{y} + 4y\right) dy = \int 3x^2 dx$$

$$\ln|y| + 2y^2 = x^3 + c$$

For every value of arbitrary constant c , this defines an exact but implicit solution $y(x)$ as it cannot be written in an explicit form $y = f(x)$.

Here are some of the solution curves for a few values of c .

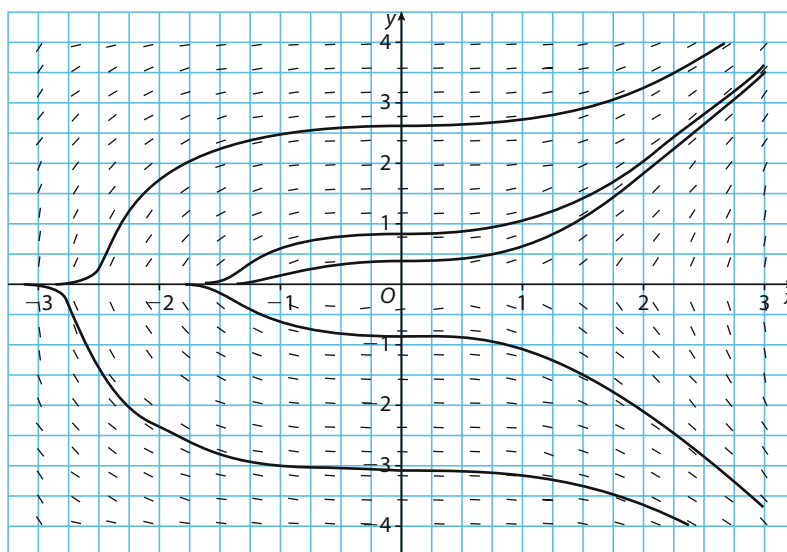

Note: Here is a summary of *solving equations by separation of variables*.

- 1 Write the differential equation in the standard form $\frac{dy}{dx} = f(x, y)$.
- 2 Can you separate the variables, i.e. is $\frac{dy}{dx} = g(x)h(y)$ or $\frac{dy}{dx} = \frac{p(x)}{q(y)}$?
- 3 If so, separate the variables, to get $\frac{dy}{h(y)} = g(x)dx$ or $q(y)dy = p(x)dx$.
- 4 Integrate both parts to get $\int \frac{dy}{h(y)} = \int g(x)dx + c$ or $\int q(y)dy = \int p(x)dx + c$.

- 5 Do the integrals if you can and don't forget the arbitrary constant. Even though we have two integrals, one on the left and one on the right, *it is enough to combine both arbitrary constants with one.*
- 6 If possible, resolve the resulting equation with respect to y , to get your equation in explicit form $y = f(x)$.

Example 53

Find the general solution of the population growth model

$$\frac{dP}{dt} = kP.$$

Solution

In this problem, we can easily separate the variables.

$$\frac{dP}{P} = kt$$

Now integrate both sides to get

$$\int \frac{1}{P} dP = \int k dt$$

$$\ln|P| = kt + c$$

where c is an arbitrary constant. This last equation can be simplified to render an explicit expression for P :

$$\ln|P| = kt + c$$

$$\Rightarrow |P| = e^{kt+c} = e^{kt}e^c = Ae^{kt}$$

where we replaced e^c with A . Thus,

$$P = Ae^{kt} \text{ or } P = -Ae^{kt}.$$

This is the general solution and all solutions to this problem will be in this form.

If the constant k is positive, the model describes population growth; if it is negative, it is decay.

The first one corresponds to positive values of k and the second to negative values of k .

If the problem above had the additional 'initial value' that at t_0 the population is P_0 , then this particular population satisfies

$$P = Ae^{kt}$$

and hence

$$P_0 = Ae^{kt_0} \Rightarrow A = \frac{P_0}{e^{kt_0}} = P_0 e^{-kt_0}$$

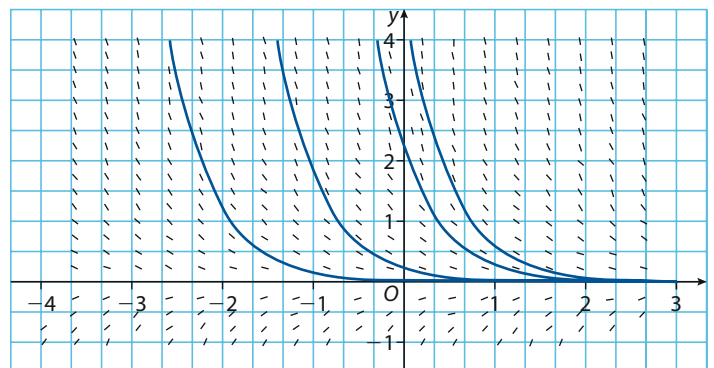
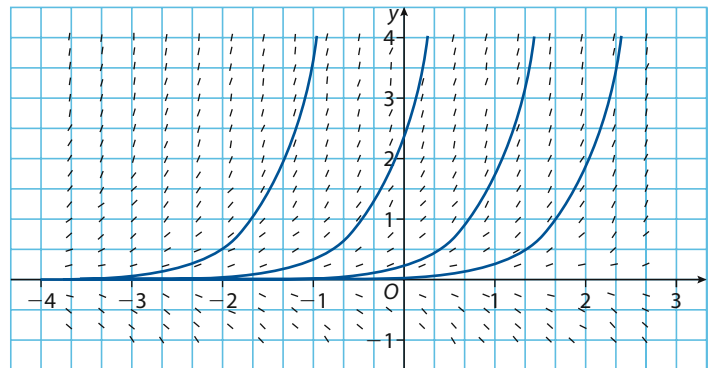

and the solution to the initial value problem is

$$P = Ae^{kt} = P_0 e^{-kt_0} e^{kt} = P_0 e^{k(t-t_0)}.$$

There is a very important special case when $t_0 = 0$. The solution becomes

$$P = P_0 e^{k(t-t_0)} = P_0 e^{kt}$$

which is the usual growth model which starts at time $t = 0$ with initial population P_0 .

Example 54

If a cold object is placed in warmer medium that is kept at a constant temperature S , then the rate of change of the temperature $T(t)$ with respect to time t is proportional to the difference between the surrounding medium and the object and hence it satisfies

$$\frac{dT}{dt} = k(S - T) \quad T(0) = T_0$$

where $k > 0$ and $T_0 < S$, i.e. the initial temperature is less than the temperature of the surrounding medium. Find the solution to the initial value problem.

Solution

It is immediately apparent that this is a variables separable type of differential equations as:

$$\frac{dT}{dt} = k(S - T) \Leftrightarrow \frac{dT}{S - T} = k dt$$

We integrate and find the general solution first.

$$\begin{aligned} \int \frac{dT}{S - T} &= \int k dt \\ -\ln|S - T| &= kt + c_1 \\ \ln|S - T| &= -kt - c_1 \end{aligned}$$

where c_1 is an arbitrary constant. Now since we know that the temperature T is less than the surrounding temperature, then

$$\ln|S - T| = \ln(S - T).$$

The general solution then is:

$$\begin{aligned} \ln(S - T) &= -kt - c_1 \\ S - T &= e^{-kt - c_1} \\ T &= S - e^{-kt - c_1} \end{aligned}$$

The initial condition implies:

$$T = S - e^{-kt - c_1}$$

$$T_0 = S - e^{0 - c_1}$$

$$e^{-c_1} = S - T_0$$

$$-c_1 = \ln(S - T_0)$$

$$c_1 = -\ln(S - T_0)$$

Therefore, substituting this value in the general solution:

$$\ln(S - T) = -kt - c_1$$

$$\ln(S - T) = -kt + \ln(S - T_0)$$

$$\ln(S - T) - \ln(S - T_0) = -kt$$

$$\ln\left(\frac{S - T}{S - T_0}\right) = -kt$$

$$\frac{S - T}{S - T_0} = e^{-kt}$$

$$S - T = (S - T_0)e^{-kt}$$

$$T = S - (S - T_0)e^{-kt}$$

This is an example of what is called ‘limited growth’. This is so because the maximum value that T can achieve is S . For example, if a can of soda is left in a room with constant temperature of 21° , then the temperature of the soda will increase to reach the room temperature!

In fact, since $k > 0$ and S is a constant, then

$$T = S - (S - T_0)e^{-kt}$$

$$\frac{dT}{dt} = k(S - T_0)e^{-kt}.$$

Also, since $T_0 < S$, then

$$\frac{dT}{dt} = k(S - T_0)e^{-kt} > 0.$$

The temperature will always increase. As time passes, i.e.

$$\lim_{t \rightarrow \infty} e^{-kt} = 0$$

$$\Rightarrow \lim_{t \rightarrow \infty} T = \lim_{t \rightarrow \infty} (S - (S - T_0)e^{-kt}) = S$$

The graph shows how the temperature climbs up to 21° but does not exceed it.

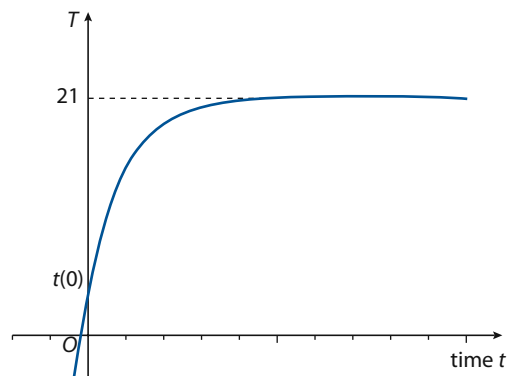

Example 55

Solve the initial value problem:

$$\frac{dy}{dx} = \frac{y}{x+1}; y(1) = 4$$

Solution

This is a variables separable type. We will separate the variables and integrate.

$$\frac{dy}{dx} = \frac{y}{x+1}$$

$$\frac{dy}{y} = \frac{dx}{x+1}$$

$$\int \frac{dy}{y} = \int \frac{dx}{x+1}$$

$$\ln|y| = \ln|x+1| + c$$

$$|y| = e^{\ln|x+1|+c} = e^{\ln|x+1|}e^c = |x+1|e^c$$

Now, since c is an arbitrary constant, we can replace e^c with a constant C , and our solution becomes

$$|y| = C|x+1|.$$

Using the initial condition:

$$4 = C|1+1| \Rightarrow C = 2, \text{ and the particular solution}$$

$$|y| = 2|x+1|, \text{ that is,}$$

$$y = \pm 2(x+1)$$

Example 56

Solve the initial value problem:

$$\frac{dy}{dt} = e^y e^{-t} \frac{1+t^2}{\cos y}; y(0) = 0$$

Solution

This problem needs some work to get it separated.

$$\frac{dy}{dt} = e^y e^{-t} \frac{1+t^2}{\cos y}$$

$$e^{-y} \cos y dy = e^{-t} (1+t^2) dt$$

Both sides need integration by parts (left as an exercise for you).

$$\int e^{-y} \cos y dy = \int e^{-t} (1+t^2) dt$$

$$\frac{1}{2} e^{-y} (\cos y - \sin y) = e^{-t} (t^2 + 2t + 3) + c$$

With initial conditions applied:

$$\begin{aligned}\frac{1}{2}e^{-y}(\cos y - \sin y) &= e^{-t}(t^2 + 2t + 3) + c \\ \frac{1}{2}e^{-0}(\cos 0 - \sin 0) &= e^{-0}(0^2 + 2(0) + 3) + c \\ \frac{1}{2} &= 3 + c \Rightarrow c = \frac{5}{2}\end{aligned}$$

Therefore, our particular solution is:

$$\begin{aligned}\frac{1}{2}e^{-y}(\cos y - \sin y) &= e^{-t}(t^2 + 2t + 3) + \frac{5}{2} \\ e^{-y}(\cos y - \sin y) &= 2e^{-t}(t^2 + 2t + 3) + 5\end{aligned}$$

Notice here that our solution cannot be expressed explicitly. In many cases, solutions to differential equations are given in implicit form.

Exercise 16.9

In questions 1–27, solve the given differential equation.

- | | |
|--|--|
| 1 $x^{-3}dy = 4ydx, y(0) = 3$ | 2 $\frac{dy}{dx} = xy, y(0) = 1$ |
| 3 $y' - xy^2 = 0, y(1) = 2$ | 4 $y' - y^2 = 0, y(2) = 1$ |
| 5 $\frac{dy}{dx} - e^y = 0, y(0) = 1$ | 6 $y'e^{y-x} = 1$ |
| 7 $\frac{dy}{dx} = y^{-2}x + y^{-2}, y(0) = 1$ | 8 $xdy - y^2dx = -dy, y(0) = 1$ |
| 9 $y^2dy - xdx = dx - dy, y(0) = 3$ | 10 $yy' = xy^2 + x, y(0) = 0$ |
| 11 $\frac{dy}{dx} = y^2x + x$ | 12 $y' = \frac{xy - y}{y + 1}, y(2) = 1$ |
| 13 $e^{x-y}dy = xdx$ | 14 $y' = xy^2 - x - y^2 + 1$ |
| 15 $xy \ln xy' = (y + 1)^2$ | 16 $\frac{dy}{dx} = \frac{1 + 2y^2}{y \sin x}$ |
| 17 $\frac{dy}{dx} = x\sqrt{\frac{1-y^2}{1-x^2}}, y(0) = 0$ | 18 $y'(1 + e^x) = e^{x-y}, y(1) = 0$ |
| 19 $(y + 1)dy = (x^2y - y)dx, y(3) = 1$ | 20 $\cos ydx + (1 + e^{-x})\sin ydy = 0, y(0) = \frac{\pi}{4}$ |
| 21 $xy' - y = 2x^2y, y(1) = 1$ | 22 $xydx + e^{-x^2}(y^2 - 1)dy = 0, y(0) = 1$ |
| 23 $(1 + \tan y)y' = x^2 + 1$ | 24 $\frac{dy}{dt} = \frac{te^t}{y\sqrt{y^2 + 1}}$ |
| 25 $y \sec \theta dy = e^y \sin^2 \theta d\theta$ | 26 $x \cos x = (2y + e^{3y})y', y(0) = 0$ |
| 27 $\frac{dy}{dx} = e^x - 2x, y(0) = 3$ | |

28 The temperature T of a kettle in a room satisfies the differential equation

$$\frac{dT}{dt} = m(T - 21), \text{ where } t \text{ is in minutes and } m \text{ is a constant.}$$

- Solve the differential equation showing that $T = Ce^{mt} + 21$, where C is an arbitrary constant.
- Given that $T(0) = 99$ and $T(15) = 69$, find
 - the value of m and C
 - t when $T = 39$.

Practice questions

- 1 The graph represents the function

$$f: x \mapsto p \cos x, p \in \mathbb{N}.$$

Find

- a) the value of p
 b) the area of the shaded region.

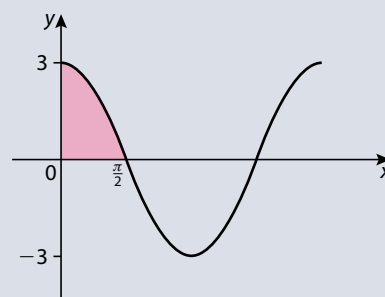

- 2 The diagram shows part of the graph of $y = e^{\frac{x}{2}}$.

- a) Find the coordinates of the point P , where the graph meets the y -axis.
 The shaded region between the graph and the x -axis, bounded by $x = 0$ and $x = \ln 2$, is rotated through 360° about the x -axis.

- b) Write down an integral that represents the volume of the solid obtained.

- c) Show that this volume is π cubic units.

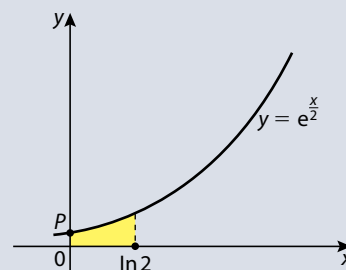

- 3 The diagram shows part of the graph of $y = \frac{1}{x}$. The area of the shaded region is 2 units.

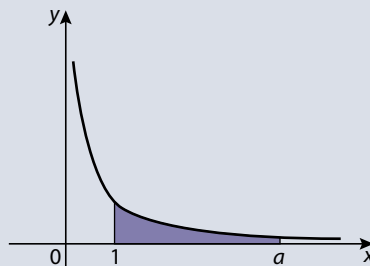

Find the exact value of a .

- 4 a) Find the equation of the tangent line to the curve $y = \ln x$ at the point $(e, 1)$, and verify that the origin is on this line.
 b) Show that $(x \ln x - x)' = \ln x$.
 c) The diagram shows the region enclosed by the curve $y = \ln x$, the tangent line in part a), and the line $y = 0$.

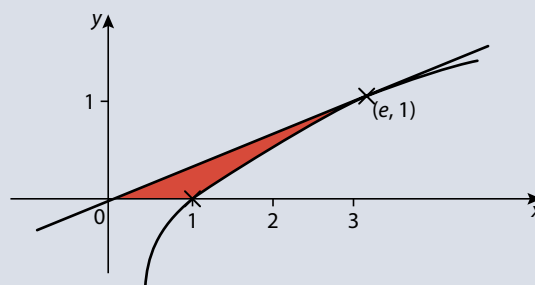

Use the result of part b) to show that the area of this region is $\frac{1}{2}e - 1$.

- 5 The main runway at Concordville airport is 2 km long. An aeroplane, landing at Concordville, touches down at point T , and immediately starts to slow down. The point A is at the southern end of the runway. A marker is located at point P on the runway.

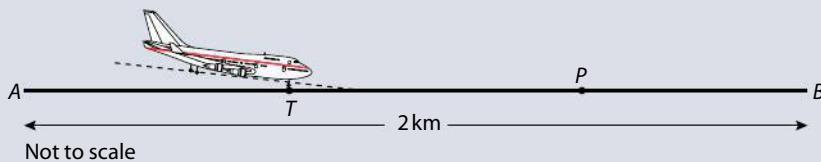

As the aeroplane slows down, its distance, s , from A , is given by

$$s = c + 100t - 4t^2$$

where t is the time in seconds after touchdown and c metres is the distance of T from A .

- a) The aeroplane touches down 800 m from A (i.e. $c = 800$).
- Find the distance travelled by the aeroplane in the first 5 seconds after touchdown.
 - Write down an expression for the velocity of the aeroplane at time t seconds after touchdown, and hence find the velocity after 5 seconds.
- The aeroplane passes the marker at P with a velocity of 36 m s^{-1} . Find
- how many seconds after touchdown it passes the marker
 - the distance from P to A .
- b) Show that if the aeroplane touches down before reaching the point P , it can stop before reaching the northern end, B , of the runway.

- 6 a) Sketch the graph of $y = \pi \sin x - x$, $-3 \leq x \leq 3$, on millimetre square paper, using a scale of 2 cm per unit on each axis. Label and number both axes and indicate clearly the approximate positions of the x -intercepts and the local maximum and minimum points.
- b) Find the solution of the equation $\pi \sin x - x = 0$, $x > 0$.
- c) Find the indefinite integral

$$\int (\pi \sin x - x) dx$$

and hence, or otherwise, calculate the area of the region enclosed by the graph, the x -axis and the line $x = 1$.

- 7 The diagram shows the graph of the function $y = 1 + \frac{1}{x}$, $0 < x \leq 4$. Find the **exact** value of the area of the shaded region.

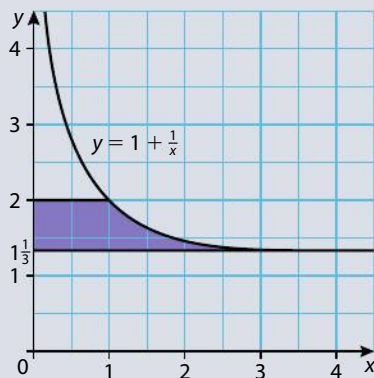

8 Note: Radians are used throughout this question.

- a) (i) Sketch the graph of $y = x^2 \cos x$, for $0 \leq x \leq 2$, making clear the approximate positions of the positive intercept, the maximum point and the endpoints.
 (ii) Write down the **approximate** coordinates of the positive x -intercept, the maximum point and the endpoints.
- b) Find the **exact value** of the positive x -intercept for $0 \leq x \leq 2$.

Let R be the region in the first quadrant enclosed by the graph and the x -axis.

- c) (i) Shade R on your diagram.
 (ii) Write down an integral that represents the area of R .
- d) Evaluate the integral in part c) (ii), either by using a graphic display calculator, or by using the following information.

$$\frac{d}{dx}(x^2 \sin x + 2x \cos x - 2 \sin x) = x^2 \cos x$$

9 Note: Radians are used throughout this question.

The function f is given by

$$f(x) = (\sin x)^2 \cos x.$$

The diagram shows part of the graph of $y = f(x)$.

The point A is a maximum point, the point B lies on the x -axis, and the point C is a point of inflexion.

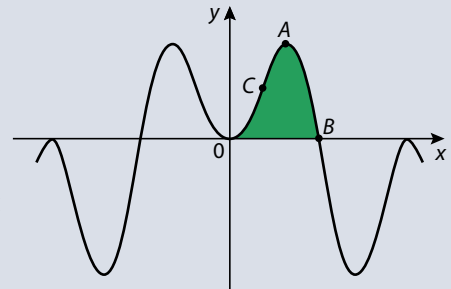

- a) Give the period of f .
- b) From consideration of the graph of $y = f(x)$, find, **to an accuracy of 1 significant figure**, the range of f .
- c) (i) Find $f'(x)$.
 (ii) Hence, show that at the point $A \cos x = \sqrt{\frac{1}{3}}$.
 (iii) Find the exact maximum value.
- d) Find the exact value of the x -coordinate at the point B .
- e) (i) Find $\int f(x) dx$.
 (ii) Find the area of the shaded region in the diagram.
- f) Given that $f''(x) = 9(\cos x)^3 - 7 \cos x$, find the x -coordinate at the point C .

10 Note: Radians are used throughout this question.

- a) Draw the graph of $y = \pi + x \cos x$, $0 \leq x \leq 5$, on millimetre square paper, using a scale of 2 cm per unit. Make clear
 (i) the integer values of x and y on each axis
 (ii) the approximate positions of the x -intercepts and the turning points.
- b) **Without the use of a calculator**, show that π is a solution of the equation $\pi + x \cos x = 0$.
- c) Find another solution of the equation $\pi + x \cos x = 0$ for $0 \leq x \leq 5$, giving your answer to 6 significant figures.
- d) Let R be the region enclosed by the graph and the axes for $0 \leq x \leq \pi$. Shade R on your diagram, and write down an integral which represents the area of R .
- e) Evaluate the integral in part d) to an accuracy of 6 significant figures. (If you consider it necessary, you can make use of the result $\frac{d}{dx}(x \sin x + \cos x) = x \cos x$.)

- 11 The diagram right shows the graphs of $f(x) = 1 + e^{2x}$ and $g(x) = 10x + 2, 0 \leq x \leq 1.5$.

- a) (i) Write down an expression for the vertical distance p between the graphs of f and g .
(ii) Given that p has a maximum value for $0 \leq x \leq 1.5$, find the value of x at which this occurs.

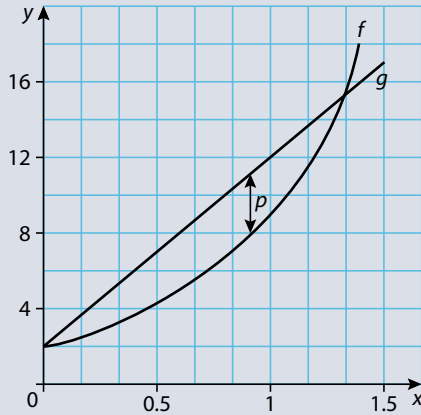

The graph of $y = f(x)$ only is shown in the diagram right. When $x = a, y = 5$.

- b) (i) Find $f^{-1}(x)$.
(ii) Hence, show that $a = \ln 2$.
c) The region shaded in the diagram is rotated through 360° about the x -axis. Write down an expression for the volume obtained.

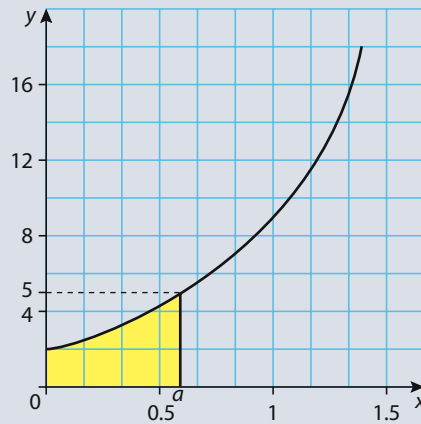

- 12 The area of the enclosed region shown in the diagram is defined by

$$y \geq x^2 + 2, y \leq ax + 2, \text{ where } a > 0.$$

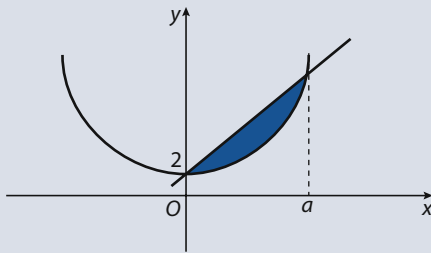

This region is rotated 360° about the x -axis to form a solid of revolution. Find, in terms of a , the volume of this solid of revolution.

- 13 Using the substitution $u = \frac{1}{2}x + 1$, or otherwise, find the integral $\int x\sqrt{\frac{1}{2}x + 1} dx$.
14 A particle moves along a straight line. When it is a distance s from a fixed point, where $s > 1$, the velocity v is given by $v = \frac{3s + 2}{2s - 1}$. Find the acceleration when $s = 2$.
15 The area between the graph of $y = e^x$ and the x -axis from $x = 0$ to $x = k$ ($k > 0$) is rotated through 360° about the x -axis. Find, in terms of k and e , the volume of the solid generated.

- 16 Find the real number $k > 1$ for which $\int_1^k \left(1 + \frac{1}{x^2}\right) dx = \frac{3}{2}$.

- 17 The acceleration, $a(t) \text{ m s}^{-2}$, of a fast train during the first 80 seconds of motion is given by

$$a(t) = -\frac{1}{20}t + 2$$

where t is the time in seconds. If the train starts from rest at $t = 0$, find the distance travelled by the train in the first minute.

- 18 In the diagram, PTQ is an arc of the parabola $y = a^2 - x^2$, where a is a positive constant, and $PQRS$ is a rectangle. The area of the rectangle $PQRS$ is equal to the area between the arc PTQ of the parabola and the x -axis.

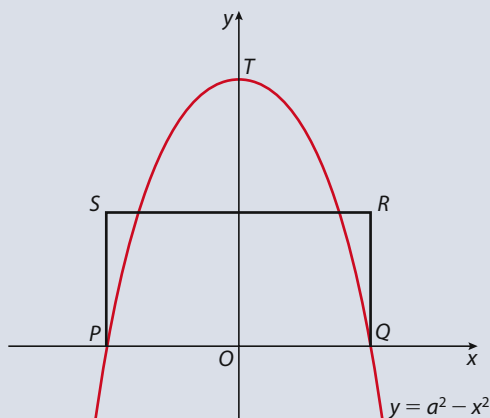

Find, in terms of a , the dimensions of the rectangle.

- 19 Consider the function $f_k(x) = \begin{cases} x \ln x - kx, & x > 0 \\ 0, & x = 0 \end{cases}$, where $k \in \mathbb{N}$

- Find the derivative of $f_k(x)$, $x > 0$.
- Find the interval over which $f(x)$ is increasing.

The graph of the function $f_k(x)$ is shown below.

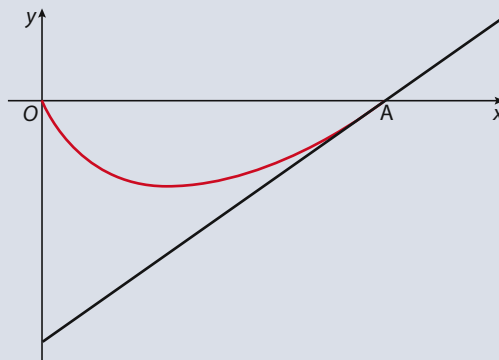

- Show that the stationary point of $f_k(x)$ is at $x = e^{k-1}$.
 - One x -intercept is at $(0, 0)$. Find the coordinates of the other x -intercept.
- Find the area enclosed by the curve and the x -axis.
- Find the equation of the tangent to the curve at A .
- Show that the area of the triangular region created by the tangent and the coordinate axes is twice the area enclosed by the curve and the x -axis.
- Show that the x -intercepts of $f_k(x)$ for consecutive values of k form a geometric sequence.

- 20 Solve the differential equation $\frac{dy}{dx} = 1 + y^2$ given that $y = 0$ when $x = 2$.

21 The equation of motion of a particle with mass m , subjected to a force kx can be written as $kx = mv \frac{dv}{dx}$, where x is the displacement and v is the velocity.

When $x = 0$, $v = v_0$. Find v , in terms of v_0 , k and m , when $x = 2$.

22 a) Sketch and label the graphs of $f(x) = e^{-x^2}$ and $g(x) = e^{x^2} - 1$ for $0 \leq x \leq 1$, and shade the region A which is bounded by the graphs and the y -axis.

b) Let the x -coordinate of the point of intersection of the curves $y = g(x)$ and $y = f(x)$ be p .

Without finding the value of p , show that

$$\frac{p}{2} < \text{area of region } A < p.$$

c) Find the value of p correct to four decimal places.

d) Express the area of region A as a definite integral and calculate its value.

23 Let $f(x) = x \cos 3x$.

a) Use integration by parts to show that

$$\int f(x) dx = \frac{1}{3}x \sin 3x + \frac{1}{9} \cos 3x + c.$$

b) Use your answer to part a) to calculate the **exact** area enclosed by $f(x)$ and the x -axis in each of the following cases. **Give your answers in terms of π .**

(i) $\frac{\pi}{6} \leq x \leq \frac{3\pi}{6}$

(ii) $\frac{3\pi}{6} \leq x \leq \frac{5\pi}{6}$

(iii) $\frac{5\pi}{6} \leq x \leq \frac{7\pi}{6}$

c) Given that the above areas are the first three terms of an arithmetic sequence, find an expression for the total area enclosed by $f(x)$ and the x -axis for

$$\frac{\pi}{6} \leq x \leq \frac{(2n+1)\pi}{6}, \text{ where } n \in \mathbb{Z}.$$

Give your answers in terms of n and π .

24 A particle is moving along a straight line so that t seconds after passing through a fixed point O on the line its velocity $v(t) \text{ m s}^{-1}$ is given by

$$v(t) = t \sin\left(\frac{\pi}{3}t\right).$$

a) Find the values of t for which $v(t) = 0$, given that $0 \leq t \leq 6$.

b) (i) Write down a mathematical expression for the **total** distance travelled by the particle in the first six seconds after passing through O .

(ii) Find this distance.

25 A particle is projected along a straight-line path. After t seconds, its velocity v metres per second is given by $v = \frac{1}{2+t^2}$.

a) Find the distance travelled in the first second.

b) Find an expression for the acceleration at time t .

- 26** The diagram below shows the shaded region R enclosed by the graph of $y = 2x\sqrt{1+x^2}$, the x -axis, and the vertical line $x = k$.

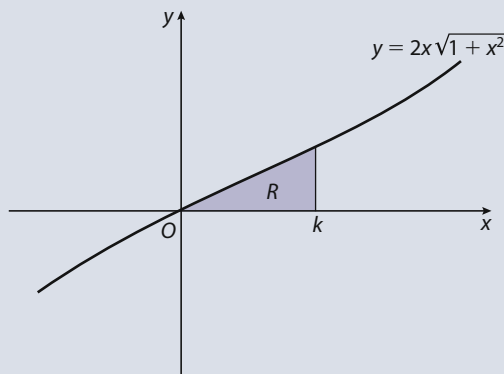

- a) Find $\frac{dy}{dx}$.
- b) Using the substitution $u = 1 + x^2$ or otherwise, show that
- $$\int 2x\sqrt{1+x^2} dx = \frac{2}{3}(1+x^2)^{\frac{3}{2}} + c.$$
- c) Given that the area of R equals 1, find the value of k .
- 27** A particle moves in a straight line with velocity, in metres per second, at time t seconds, given by
- $$v(t) = 6t^2 - 6t, \quad t \geq 0.$$
- Calculate the total distance travelled by the particle in the first two seconds of motion.
- 28** A particle moves in a straight line. Its velocity v m s⁻¹ after t seconds is given by
- $$v = e^{-\sqrt{t}} \sin t.$$
- Find the total distance travelled in the time interval $[0, 2\pi]$.
- 29** The temperature T °C of an object in a room, after t minutes, satisfies the differential equation
- $$\frac{dT}{dt} = k(T - 22), \quad \text{where } k \text{ is a constant.}$$
- a) Solve the differential equation showing that $T = Te^{kt} + 22$, where A is a constant.
- b) When $t = 0$, $T = 100$, and when $t = 15$, $T = 70$.
- (i) Use this information to find the value of A and of k .
- (ii) Hence, find the value of t when $T = 40$.
- 30** Solve the differential equation $x \frac{dy}{dx} - y^2 = 1$ given that $y = 0$ when $x = 2$. Give your answer in the form $y = f(x)$.
- 31** Use the substitution $u = x + 2$ to find $\int \frac{x^3}{(x+2)^2} dx$.
- 32 a)** On the same axes sketch the graphs of the functions, $f(x)$ and $g(x)$, where
- $$f(x) = 4 - (1-x)^2, \quad \text{for } -2 \leq x \leq 4,$$
- $$g(x) = \ln(x+3) - 2, \quad \text{for } -3 \leq x \leq 5.$$



- b) (i) Write down the equation of any vertical asymptotes.
(ii) State the x -intercept and y -intercept of $g(x)$.
- c) Find the values of x for which $f(x) = g(x)$.
- d) Let A be the region where $f(x) \geq g(x)$ and $x \geq 0$.
 - (i) On your graph shade the region A .
 - (ii) Write down an integral that represents the area of A .
 - (iii) Evaluate this integral.
- e) In the region A find the maximum vertical distance between $f(x)$ and $g(x)$.

33 Consider the differential equation $\frac{dy}{d\theta} = \frac{y}{e^{2\theta} + 1}$.

- a) Use the substitution $x = e^\theta$ to show that

$$\int \frac{dy}{y} = \int \frac{dx}{x(x^2 + 1)}.$$

- b) Find $\int \frac{dx}{x(x^2 + 1)}$.

- c) Hence, find y in terms of θ , if $y = \sqrt{2}$ when $\theta = 0$.

Questions 1–11: © International Baccalaureate Organization

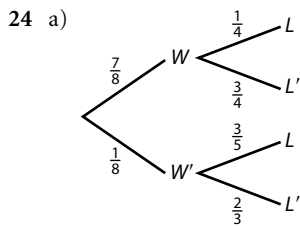

- b) $\frac{47}{160}$ c) $\frac{35}{47}$
 25 a) $\frac{1}{3}$ b) $\frac{7}{12}$ c) $\frac{3}{7}$

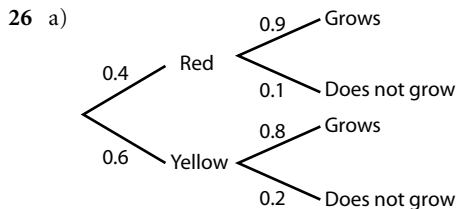

- b) (i) 0.36 (ii) 0.84 (iii) 0.429
 27 a) $\frac{1}{6}$ b) $\frac{1}{12}$ c) $\frac{2}{9}$
 28 a) (i) $\frac{8}{21}$ (ii) $\frac{1}{6}$ (iii) no, $P(A \cap B) \neq P(A)P(B)$
 b) $\frac{10}{17}$ c) $\frac{200}{399}$
 29 $\frac{1}{3}$ 30 $\frac{4}{5}$ 31 0.00198 32 $\frac{19}{30}$
 33 0.80 34 $\frac{10}{19}$ 35 a) $\frac{13}{20}$ b) $\frac{11}{15}$
 36 $\frac{2}{5}$
 37 a) (i) $\frac{5}{36}$ (ii) $\frac{25}{216}$ (iii) $\frac{1}{6} \left(\frac{5}{6}\right)^{2n-2}$
 b) No answer required – proof
 c) $\frac{5}{11}$ d) 0.432
 38 a) 0.957 b) 0.301
 39 $\frac{1}{9}$
 40 a) 0.25 b) 0.083
 41 a) 0.80 b) 0.56
 42 a) 0.732 b) $\frac{11}{61}$
 43 a) $\frac{2}{3}$ b) $\frac{2}{9}$ c) $\frac{3}{4}$
 44 a) $\frac{1}{10}$ b) proof
 c) $\frac{11}{90}$ d) $\frac{3}{11}$
 45 $\frac{3}{7}$

Chapter 13

Exercise 13.1

- 1 4 2 $3x^2$ 3 $2x$ 4 6
 5 0 6 $\frac{5}{2}$ 7 d.n.e. (increases without bound)
 8 $\frac{1}{8}$ 9 $\frac{3}{2}$ 10 $\frac{\sqrt{2}}{4}$ 11 $\frac{1}{4}$
 12 1 13 3 14 $\frac{1}{e}$
 15 $\frac{d}{dx} [\log_b x] = \frac{1}{x \ln b}$
 16 As $x \rightarrow a$, $g(x) \rightarrow +\infty$
 17 a) Horizontal: $y = 3$; vertical: $x = -1$
 b) Horizontal: $y = 0$; vertical: $x = 2$
 c) Horizontal: $y = b$; vertical: $x = a$
 d) Horizontal: $y = 2$; vertical: $x = \pm 3$
 e) Horizontal: $y = 0$; vertical: $x = 0$, $x = 5$
 f) Horizontal: none; vertical: $x = 4$

- 18 $\frac{1}{3}$ 19 4

Exercise 13.2

- 1 $f'(x) = -2x$ 2 $g'(x) = 3x^2$
 3 $h'(x) = \frac{1}{2\sqrt{x}}$ 4 $r'(x) = -\frac{2}{x^3}$
 5 (i)

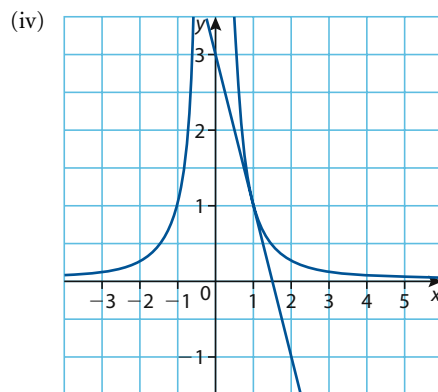
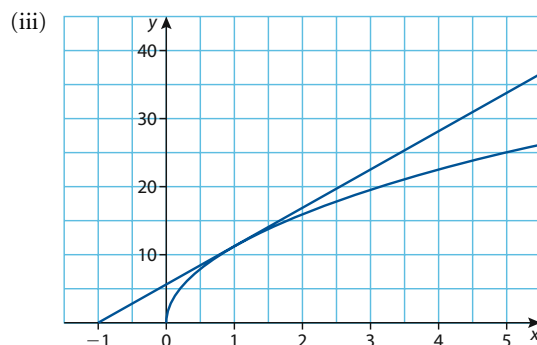
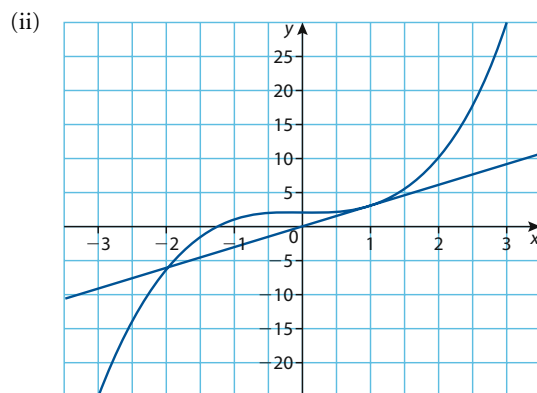
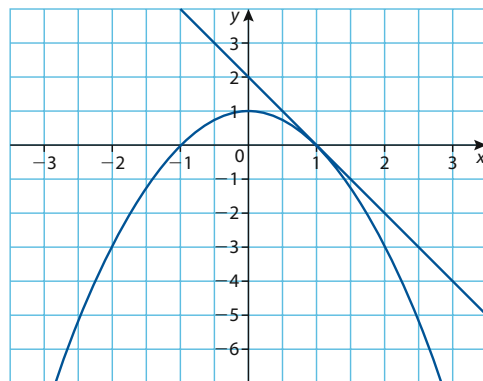

- 6 a) $y' = 6x - 4$ b) -4
 7 a) $y' = -2x - 6$ b) 0

- 8 a) $y' = -\frac{6}{x^4}$ b) -6

- 9 a) $y' = 5x^4 - 3x^2 - 1$ b) 1

- 10 a) $y' = 2x - 4$ b) 0

- 11 a) $y' = 2 - \frac{1}{x^2} + \frac{9}{x^4}$ b) 10

- 12 a) $y' = 1 - \frac{2}{x^3}$ b) 3

- 13 $a = -5, b = 2$ 14 $(0, 0)$

- 15 $(2, 8)$ and $(-2, -8)$ 16 $(\frac{5}{2}, -\frac{21}{4})$

- 17 $(1, -2)$

- 18 a) Between A and B

- b) Rate of change is positive at A, B and F;
 rate of change is negative at D and E;
 rate of change is zero at C

- c) Pair B and D, and pair E and F

- 19 $a = 1, b = 5$ 20 $a = 1$ 21 $(3, 6)$

- 22 a) 12.61 b) 12 23 $f'(x) = 2ax + b$

- 24 a) 4.6 degrees Celsius per hour

- b) $C'(t) = 3\sqrt{t}$

- c) $t = \frac{196}{81} \approx 2.42$ hours

- 25–26 Proof

- 27 $\frac{1}{2\sqrt{x}}$ 28 $-\frac{1}{x^2}$

- 29 $\frac{5}{(3-x)^2}$ [or $\frac{5}{(x-3)^2}$] 30 $-\frac{1}{2\sqrt{(x+2)^3}}$

Exercise 13.3

- 1 $(1, -7)$ 2 $(-\frac{3}{2}, 8)$ 3 $(3, 2)$

- 4 a) $y' = 2x - 5$ b) increasing for $x > \frac{5}{2}$

- c) decreasing for $x < \frac{5}{2}$

- 5 a) $y' = -6x - 4$ b) increasing for $x < -\frac{2}{3}$

- c) decreasing for $x > -\frac{2}{3}$

- 6 a) $y' = x^2 - 1$ b) increasing for $x > 1, x < -1$

- c) decreasing for $-1 < x < 1$

- 7 a) $y' = 4x^3 - 12x^2$ b) increasing for $x > 3$

- c) decreasing for $x < 0, 0 < x < 3$

- 8 a) $(3, -130), (-4, 213)$

- b) $(3, -130)$ minimum because 2nd derivative is positive at $x = 3$

- $(-4, 213)$ maximum because 2nd derivative is negative at $x = -4$

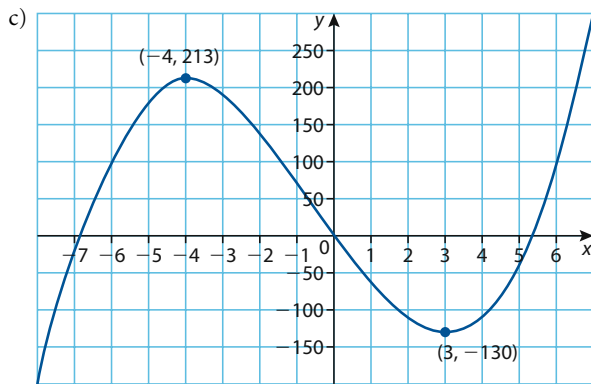

- 9 a) $(0, -5)$
 b) Stationary point is neither a maximum nor minimum because 1st derivative is always positive.

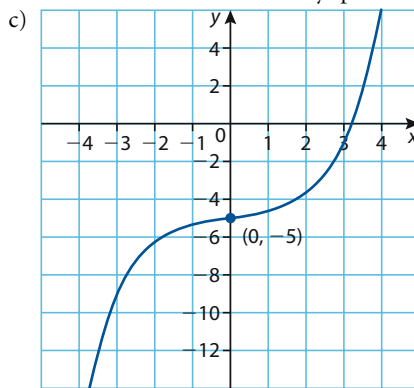

- 10 a) $(1, 4), (3, 0)$
 b) $(1, 4)$ maximum because 2nd derivative is negative at $x = 1$
 $(3, 0)$ minimum because 2nd derivative is positive at $x = 3$

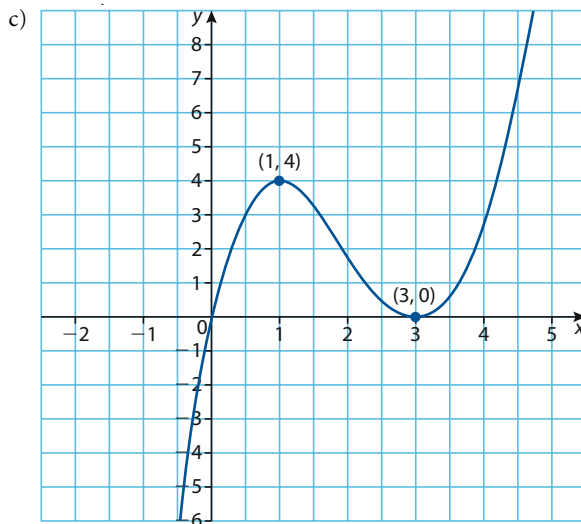

- 11 a) $(-1, 4), (0, 6), (\frac{5}{2}, -\frac{279}{16})$
 b) $(-1, 4)$ minimum because 2nd derivative is positive at $x = -1$
 $(0, 6)$ maximum because 2nd derivative is negative at $x = 0$

at $\left(\frac{5}{2}, -\frac{279}{16}\right)$ minimum because 2nd derivative is positive

c) $x = \frac{5}{2}$

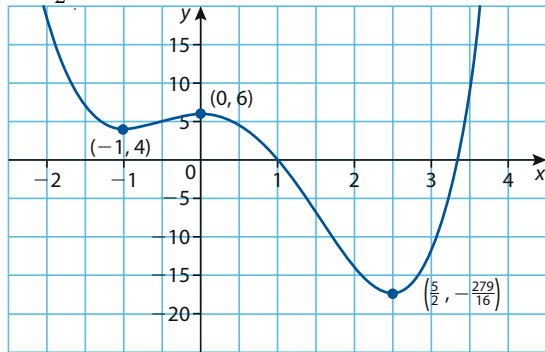

12 a) $(-1, 14), \left(\frac{7}{3}, -\frac{122}{27}\right)$

b) $(-1, 14)$ maximum because 2nd derivative is negative at $x = -1$

$\left(\frac{7}{3}, -\frac{122}{27}\right)$ minimum because 2nd derivative is positive at

c) $x = \frac{7}{3}$

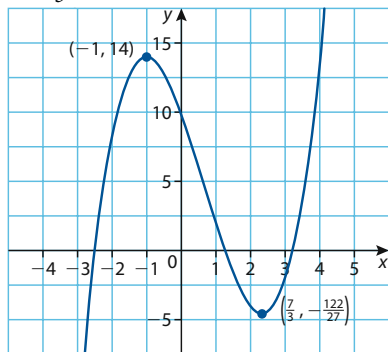

13 a) $\left(\frac{1}{4}, -\frac{1}{4}\right)$

b) $\left(\frac{1}{4}, -\frac{1}{4}\right)$ minimum because 2nd derivative is positive at

$x = \frac{1}{4}$

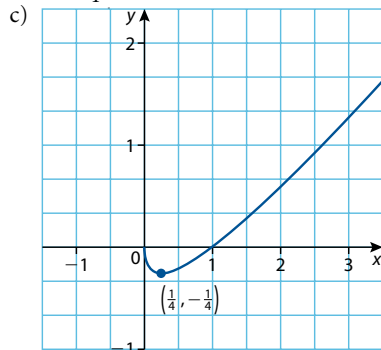

14 a) $v(t) = 3t^2 - 8t + 1; a(t) = 6t - 8$

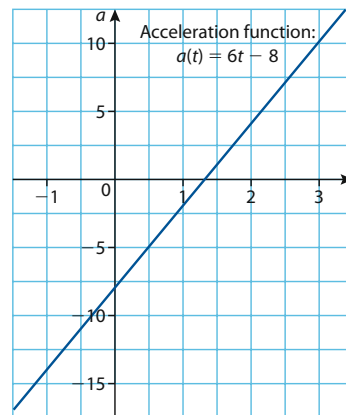
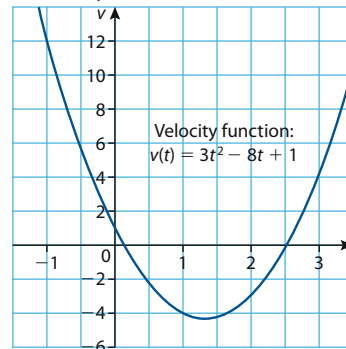
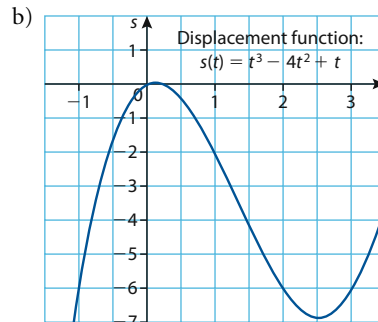

c) $t \approx 0.131$, displacement ≈ 0.0646

d) $t = 1.\bar{3}$, displacement = $-4.\bar{3}$

e) Object moves right at a decreasing velocity then turns left with increasing velocity then slowing down and turning right with increasing velocity.

15 Relative maximum at $(-2, 16)$; relative minimum at $(2, 16)$; inflexion point at $(0, 0)$

16 Absolute minima at $(-2, -4)$ and $(2, -4)$; relative maximum at $(0, 0)$; inflexion points at $\left(-\frac{2\sqrt{3}}{3}, -\frac{20}{9}\right)$ and $\left(\frac{2\sqrt{3}}{3}, -\frac{20}{9}\right)$

17 Relative maximum at $(-2, -4)$; relative minimum at $(2, 4)$; no inflexion points

18 Relative minimum at $\left(-\frac{\sqrt[3]{4}}{2}, \frac{3\sqrt[3]{2}}{2}\right)$; inflexion point at $(1, 0)$

19 Relative minimum at $(-1, -2)$; relative maximum at $(1, 2)$; inflexion points at $\left(-\frac{\sqrt{2}}{2}, -\frac{7\sqrt{2}}{8}\right), (0, 0)$ and $\left(\frac{\sqrt{2}}{2}, \frac{7\sqrt{2}}{8}\right)$

20 Relative minimum at $(-1, 0)$; absolute minimum at $(2, -27)$; relative maximum at $(0, 5)$; inflexion points at $(1.22, -13.4)$ and $(-0.549, 2.32)$

21 a) $v(0) = 27 \text{ m s}^{-1}, a(0) = -66 \text{ m s}^{-2}$

- b) $v(3) = 45 \text{ m s}^{-1}$, $a(3) = 78 \text{ m s}^{-2}$
 c) $t = \frac{1}{2}$ and $t = 2\frac{1}{4}$; where displacement has a relative maximum or minimum
 d) $t = \frac{11}{8} = 1.375$; where acceleration is zero

22 $x \approx 5.77$ tonnes; $D \approx 34.6$ (\$34 600); this cost is a minimum because cost decreases to this value then increases

23 $a = -3$, $b = 4$, $c = -2$

24 Relative maximum at $(-2, -\frac{15}{4})$, stationary inflexion point at $(1, 3)$
 $f(x) \rightarrow x$ as $x \rightarrow \pm\infty$

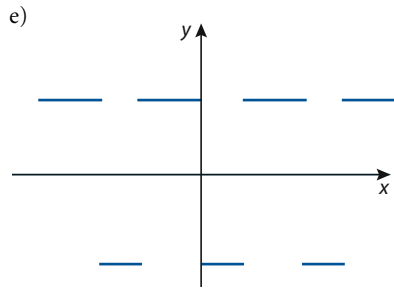
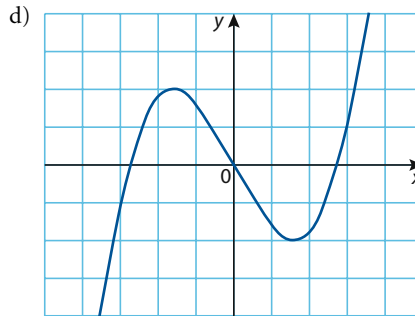
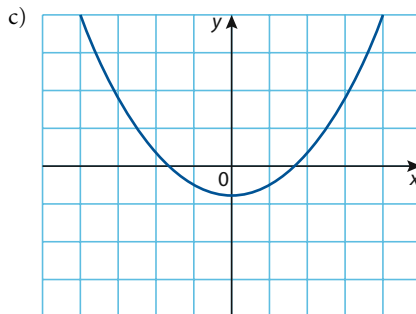
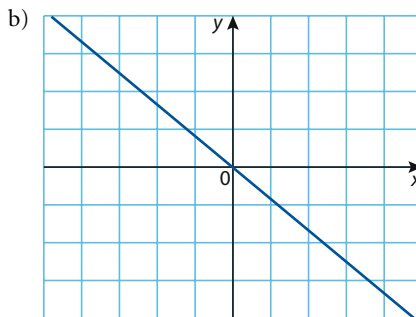
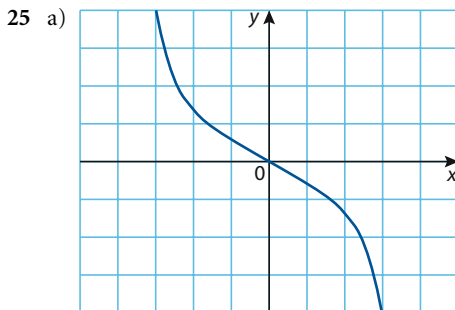
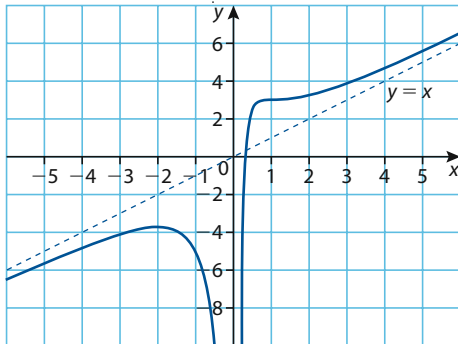

- 26 a) Increasing on $1 < x < 5$; decreasing on $x < 1$, $x > 5$
 b) Minimum at $x = 1$; maximum at $x = 5$
 27 a) Increasing on $0 \leq x < 1$, $3 < x < 5$; decreasing on $1 < x < 3$, $x > 5$
 b) Minimum at $x = 3$; maximum at $x = 1$ and $x = 5$
 28 $x \approx 0.5$ and $x \approx 7.5$

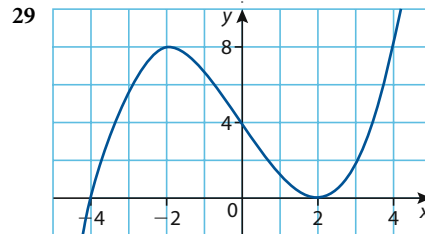

- 30 a) Right $1 < t < 4$; left $t < 1$, $t > 4$
 b) $v_0 = -24$, $a_0 = 30$
 c) $d_{\max} = 16$ at $t = 4$, $v_{\max} = 13.5$ at $t = 2.5$
 d) Velocity is maximum at $t = 2.5$
 31 a) Maximum at $x \approx 6.50$, minimum at $x \approx -0.215$
 b) Maximum is $\frac{7\pi}{4} + 1$, minimum is $\frac{\pi}{4} - 1$

Exercise 13.4

- 1 a) $y = -4x - 8$ b) $y = \frac{4}{27}$
 c) $y = -x + 1$ d) $y = -2x + 4$
 2 a) $y = \frac{1}{4}x + \frac{19}{4}$ b) $x = -\frac{2}{3}$
 c) $y = x + 1$ d) $y = \frac{1}{2}x + \frac{11}{4}$
 3 At $(0, 0)$: $y = 2x$; at $(1, 0)$: $y = -x + 1$; at $(2, 0)$: $y = 2x - 4$
 4 $y = -2x$
 5 a) $x = 1$
 b) For $y = x^2 - 6x + 20$, eq. of tangent is $y = -4x + 19$
 For $y = x^3 - 3x^2 - x$, eq. of tangent is $y = -4x + 1$
 6 Normal: $y = \frac{1}{2}x - \frac{7}{2}$; intersection pt: $(-\frac{1}{2}, -\frac{15}{4})$
 7 Eq. of tangent: $y = -3x + 3$; eq. of normal: $y = \frac{1}{3}x - \frac{1}{3}$
 8 $a = 4$, $b = -7$

9 a) $y = 2x + \frac{5}{2}$ b) $(\frac{2}{3}, \frac{41}{27})$

10 Eq. of tangent: $y = -\frac{3}{4}x + 1$; eq. of normal:
 $y = \frac{4}{3}x - \frac{22}{3}$

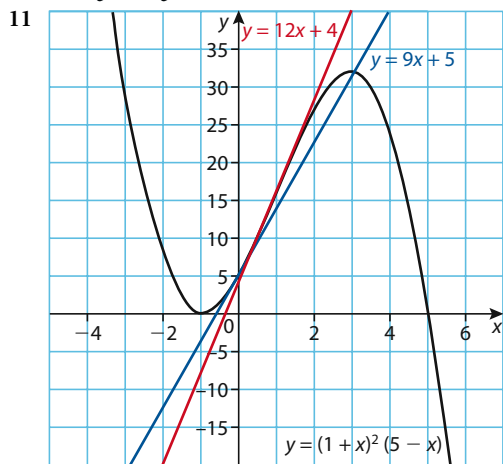

12 $y = 11x - 25$ and $y = -x - 1$

13 $y = (2\sqrt{2} - 2)x$ and $y = -(2\sqrt{2} + 2)x$

14 a) $y = \frac{1}{12}x + \frac{4}{3}$ b) $\sqrt[3]{9} \approx 2.08$

15 $y = -\frac{1}{2\sqrt{a^3}}x + \frac{3}{2\sqrt{a}}$

16 $x_Q = -2x_P, y_Q = -8y_P$

Practice questions

1 a) Gradient = 3 b) $y = 3x - \frac{9}{4}$

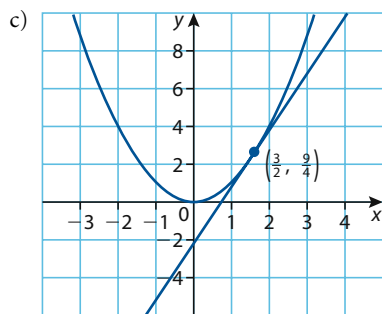

d) $Q(\frac{3}{4}, 0), R(0, -\frac{9}{4})$

f) $y = 2ax - a^2$

g) $T(\frac{a}{2}, 0), U(0, -a^2)$

h) x-coord.: $\frac{a+0}{2} = \frac{a}{2}$; y-coord.: $\frac{a^2 - a^2}{2} = 0$

2 $A = 1, B = 2, C = 1$

3 a) $4x - 15x^4$

b) $-\frac{1}{x^2}$

4 a) $x = 2$ or -2 ; $f'(1) = -6 < 0$ (decreasing) and

$f'(3) = \frac{10}{9} > 0$ (increasing) $\therefore f(2)$ is a turning point

b) vertical asymptote: $x = 0$ (y -axis); oblique asymptote: $y = 2x$

5 $(\frac{1}{2}, 3)$

6 $a = 1$

7 a) $y = 5x - 7$

b) $y = -\frac{1}{5}x + \frac{17}{5}$

8 a) $x = 1$

b) $-3 < x < -2, 1 < x < 3$

c) $x = -\frac{1}{2}$

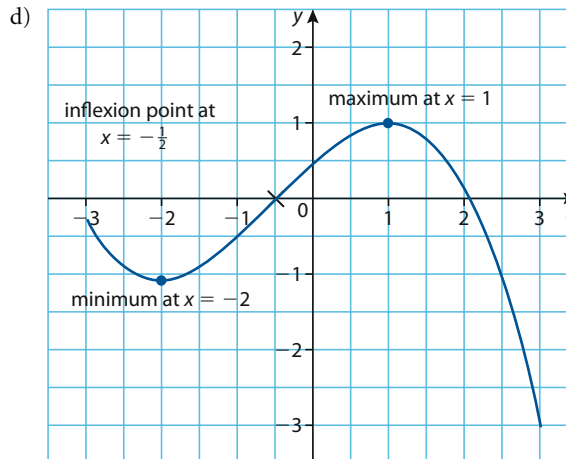

9 $b = 2, c = 3$

10

function	diagram
f_1	d
f_2	e
f_3	b
f_4	a

11 a) $\frac{2}{\pi}$ b) $\frac{\sqrt{2}}{2}$ c) $x \approx 0.881$

12 a) (i) $x = 0$ (ii) $y = 3$

b) $\frac{dy}{dx} = \frac{2}{x^2}$

c) Increasing for all x , except $x = 0$

d) No stationary points because $\frac{dy}{dx} = \frac{2}{x^2} \neq 0$

13 Maximum at $(-1, 1)$, minimum at $(0, 0)$, maximum at $(1, 1)$

14 $a = \frac{8}{3}, b = \frac{16}{5}$

15 a) 10 m s^{-1} b) 10 sec c) 50 metres

16 a) $v = 14 - 9.8t$

b) $t \approx 1.43$ sec

c) Velocity = 0, acceleration = -9.8 m s^{-2}

17 $(-4, 120)$

18 a) $y = (-\sqrt{3})x + \frac{\pi\sqrt{3}}{3} - 2$

b) $y = (\frac{\sqrt{3}}{3})x - \frac{\pi\sqrt{3}}{9} - 2$

19 a) $h = \frac{27 - r^2}{r}; V = \pi r(27 - r^2)$

b) $r = 3$

20 $a = -2, b = 8, c = 10$

21 a) $y = -7x + 1$

b) $y = \frac{x}{7} + \frac{107}{7}$

22 a) Absolute minimum at $(\frac{3}{4}, -\frac{27}{256})$

b) Domain: $x \in \mathbb{R}$, range: $y \geq -\frac{27}{256}$

c) Inflexion points at $(0, 0)$ and $(\frac{1}{2}, -\frac{1}{16})$

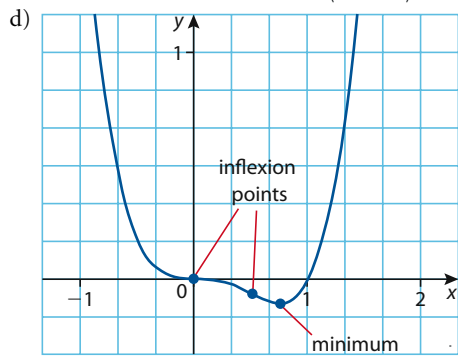

23 a) $-\frac{5}{3}$ b) $\frac{1}{4}$ c) 3 d) $\frac{1}{2\sqrt{x+2}}$

24 a) $f'(x) = \frac{3x-4}{2\sqrt{x}}$

b) $f'(x) = 3x^2 - 3\cos x$

c) $f'(x) = -\frac{1}{x^2} + \frac{1}{2}$

d) $f'(x) = -\frac{91}{3x^{14}}$

25 3 solutions: $(\frac{11}{2}, \frac{1105}{8})$, $(2, -15)$, and $(-2, 5)$

26 $\frac{17}{2}$

27 $(2, \frac{2}{3}), (-2, -\frac{2}{3})$

28 $(-1, -2)$

30 $(2, 20), (4, 16)$

31 a) particle does not change direction for $0 \leq t \leq 2\pi$

b) $v = 1 + \cos t \geq 0$ for $0 \leq t \leq 2\pi$

c) $t = 0, \pi, 2\pi$

d) Maximum value of s is 2π

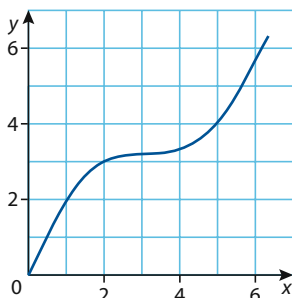

32 $a = \frac{1}{4}, b = \frac{3}{4}, c = -6, d = -\frac{5}{2}$; y -coord. is $-\frac{19}{2}$

33 Absolute minimum points at $(-2, -\frac{1}{8})$ and $(2, -\frac{1}{8})$

34 a) $y = -x + 2$

b) $y = -x + \frac{\pi}{2}$

35 b) $y = 2x, (1, 2)$

36 a) $v = 50 - 20t$

b) $s = 1062.5$ m

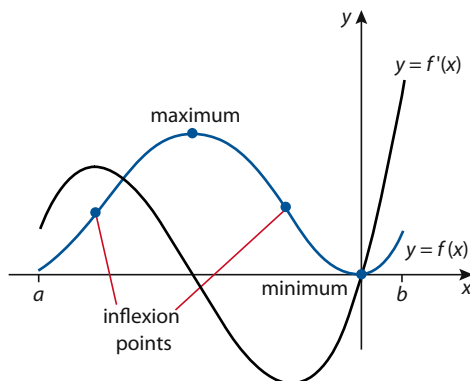

Chapter 14

Exercise 14.1

1 a) $(\frac{5}{2}, -2, 0)$

b) $(3, 2\sqrt{3}, 0)$

c) $(-1, 2, -2)$

d) $(a, -4a, -a)$

2 a) $Q(-\frac{1}{2}, -3, 2)$

b) $P(\frac{5}{2}, -2, 0)$

c) $Q(0, -4a, 3a)$

3 a) $(x, y, z) = (t, t, 5 - 5t)$, or $(x, y, z) = (1 + t, 1 + t, -5t)$

b) $(x, y, z) = (-1 + 4t, 5t, 1 - 3t)$

c) $(x, y, z) = (2 - 4t, 3 - 6t, 4 + t)$

4 a) $C(7, -8, -1)$

b) $C(-1, \frac{11}{2}, \frac{29}{3})$

c) $C(2 - a, 4 - 2a, -b - 2)$

5 a) $(-\frac{1}{3}, 1, \frac{1}{3})$

b) $(1, -\frac{5}{3}, -1)$

c) $(\frac{a+b+c}{3}, \frac{2a+2b+2c}{3}, a+b+c)$

6 a) $D(-1, 1, -6)$

b) $D(-2\sqrt{2}, 2\sqrt{3}, 1 - 4\sqrt{5})$

c) $D(\frac{5}{2}, -\frac{2}{3}, -4)$

7 $m = 5, n = 1$

8 a) $\mathbf{v} = \frac{2}{3}\mathbf{i} + \frac{2}{3}\mathbf{j} - \frac{1}{3}\mathbf{k}$

b) $\mathbf{v} = \frac{3}{\sqrt{14}}\mathbf{i} - \frac{2}{\sqrt{14}}\mathbf{j} + \frac{1}{\sqrt{14}}\mathbf{k}$

c) $\mathbf{v} = \frac{2}{3}\mathbf{i} - \frac{1}{3}\mathbf{j} - \frac{2}{3}\mathbf{k}$

9 a) $\frac{2}{3}(2\mathbf{i} + 2\mathbf{j} - \mathbf{k})$

b) $\frac{2}{\sqrt{14}}(6\mathbf{i} - 4\mathbf{j} + 2\mathbf{k})$

c) $\frac{5}{3}(2\mathbf{i} - \mathbf{j} - 2\mathbf{k})$

10 a) $|\mathbf{u} + \mathbf{v}| = \sqrt{29}$

b) $|\mathbf{u}| + |\mathbf{v}| = \sqrt{14} + \sqrt{5}$

c) $|-3\mathbf{u}| + |3\mathbf{v}| = 3\sqrt{14} + 3\sqrt{5}$

d) $\frac{1}{|\mathbf{u}|}\mathbf{u} = \frac{\mathbf{i}}{\sqrt{14}} + \frac{3\mathbf{j}}{\sqrt{14}} - \frac{2\mathbf{k}}{\sqrt{14}}$

e) $|\frac{1}{|\mathbf{u}|}\mathbf{u}| = 1$

11 a) $(3, 4, -5)$

b) $(0, -2, 5)$

- 12 a) $(1, -\frac{4}{3})$ b) $\sqrt{6}(4\mathbf{i} + 2\mathbf{j} - 2\mathbf{k})$ c) $-\frac{2}{3}\mathbf{i} + \frac{8}{3}\mathbf{j} - 2\mathbf{k}$
 13 0 14 $\pm \frac{\sqrt{14}}{14}$ 15 None 16 None
 17 a) $\mathbf{a} = (8, 0, 0)$, $\mathbf{b} = (8, 8, 0)$, $\mathbf{c} = (0, 8, 0)$, $\mathbf{d} = (0, 0, 8)$,
 $\mathbf{e} = (8, 0, 8)$, $\mathbf{f} = (8, 8, 8)$
 b) $\mathbf{l} = (8, 4, 8)$, $\mathbf{m} = (4, 8, 8)$, $\mathbf{n} = (8, 8, 4)$
 c) proof
 18 a) $\mathbf{c} = (8, 0, 12)$, $\mathbf{d} = (0, 10, 12)$
 b) $\mathbf{f} = (4, 5, 0)$, $\mathbf{g} = (4, 5, 12)$
 c) $\overrightarrow{AG} = (-4, 5, 12) = \overrightarrow{FD}$
 19 $\pm \frac{\sqrt{6}}{3}$
 20 $(\alpha, \beta, \mu) = (\frac{31}{7}, -\frac{15}{7}, \frac{6}{7})$ 21 $(\alpha, \beta, \mu) = (2, -1, 3)$
 22 Not possible 23 Rectangle
 24 $T_1 = 125(\sqrt{3} - 1) \text{ N}$; $T_2 = 175(\frac{3\sqrt{2} - \sqrt{6}}{2}) \text{ N}$
 25 $T_1 = 150 \text{ N}$; $T_2 = 150\sqrt{3} \text{ N}$

Exercise 14.2

- 1 a) $-16, 117.65^\circ$ b) $-20, 64.68^\circ$ c) $13, 40.24^\circ$
 d) $-15, 151.74^\circ$ e) $6, 60^\circ$ f) $-6, 120^\circ$
 2 a) Orthogonal b) acute c) orthogonal
 3 a) $\mathbf{v} \cdot \mathbf{u} = 0 = \mathbf{w} \cdot \mathbf{u}$ b) $\frac{3}{\sqrt{13}}\mathbf{i} + \frac{2}{\sqrt{13}}\mathbf{j}, \frac{-3}{\sqrt{13}}\mathbf{i} - \frac{2}{\sqrt{13}}\mathbf{j}$
 4 a) (i) $\cos \alpha = \frac{2}{\sqrt{14}}$, $\cos \beta = \frac{-3}{\sqrt{14}}$, $\cos \gamma = \frac{1}{\sqrt{14}}$
 (ii) $\cos^2 \alpha + \cos^2 \beta + \cos^2 \gamma = \frac{2^2}{14} + \frac{(-3)^2}{14} + \frac{1^2}{14} = 1$
 (iii) $\alpha \approx 58^\circ$, $\beta \approx 143^\circ$, $\gamma \approx 74^\circ$
 b) (i) $\cos \alpha = \frac{1}{\sqrt{6}}$, $\cos \beta = \frac{-2}{\sqrt{6}}$, $\cos \gamma = \frac{1}{\sqrt{6}}$
 (ii) $\cos^2 \alpha + \cos^2 \beta + \cos^2 \gamma = \frac{1^2}{6} + \frac{2^2}{6} + \frac{1^2}{6} = 1$
 (iii) $\alpha \approx 66^\circ$, $\beta \approx 145^\circ$, $\gamma \approx 66^\circ$
 c) (i) $\cos \alpha = \frac{3}{\sqrt{14}}$, $\cos \beta = \frac{-2}{\sqrt{14}}$, $\cos \gamma = \frac{1}{\sqrt{14}}$
 (ii) $\cos^2 \alpha + \cos^2 \beta + \cos^2 \gamma = \frac{3^2}{14} + \frac{(-2)^2}{14} + \frac{1^2}{14} = 1$
 (iii) $\alpha \approx 37^\circ$, $\beta \approx 122^\circ$, $\gamma \approx 74^\circ$
 d) (i) $\cos \alpha = \frac{3}{5}$, $\cos \beta = 0$, $\cos \gamma = \frac{-4}{5}$
 (ii) $\cos^2 \alpha + \cos^2 \beta + \cos^2 \gamma = \frac{3^2}{25} + \frac{0^2}{25} + \frac{4^2}{25} = 1$
 (iii) $\alpha \approx 53^\circ$, $\beta \approx 90^\circ$, $\gamma \approx 143^\circ$
 5 $\begin{pmatrix} \frac{1}{2} \\ \frac{\sqrt{2}}{2} \\ -\frac{1}{2} \end{pmatrix}$ 6 $\begin{pmatrix} \frac{3\sqrt{2}}{2} \\ \frac{3\sqrt{2}}{2} \\ 0 \end{pmatrix}$
 7 a) $m = -\frac{9}{8}$ b) $m = 1$ or $-\frac{1}{4}$
 8 $m = -14$
 9 a) 127° b) 63° c) 73°
 10 a) $m = \frac{1}{3}$ b) $m = -\frac{1}{4}$
 11 $m_A: \mathbf{r} = (4, -2, -1) + m(-1, 0, \frac{3}{2})$;
 $m_B: \mathbf{r} = (3, -5, -1) + n(\frac{1}{2}, \frac{9}{2}, \frac{3}{2})$
 $m_C: \mathbf{r} = (3, 1, 2) + k(\frac{1}{2}, -\frac{9}{2}, -3)$; centroid $(\frac{10}{3}, -2, 0)$
 12 90, 90, 82, 74, 60, 54, 53, 52, 47, 43, 38, 37

- 13 68.22
 14 $103.3^\circ, 133.5^\circ, 46.5^\circ$
 15 0
 16 $k = 2$
 17 $k = 0$ or $k = 4$
 18 $x = -20, y = -14$
 19 $x = 5$
 20 $117^\circ, \overrightarrow{AC} = \begin{pmatrix} 0 \\ 6 \\ 3 \end{pmatrix}, 33^\circ$
 21 a) $b = -\frac{1}{2}$ b) $b = 0$ or $b = \frac{1}{2}$
 c) $b = \frac{5}{2}$ or $b = 3$ d) $b = \pm 4$
 22 a) $b = -\frac{1}{2}$ b) $b = \frac{1}{2}$
 23 $(-140.8, 140.8, 18)$ 24 $t = 2$
 25 $t = -\frac{1}{2}$ 26 $t = 0$ or $t = \frac{1}{2}$
 27 90° or $\cos^{-1}(\frac{2}{\sqrt{6}})$ 28 Proof
 29 $m = \frac{7}{4}, n = -\frac{1}{4}$ 30 Proof
 31 $\frac{\pi}{3}, -\frac{2\pi}{3}$ 32 $\cos^{-1}(\pm \frac{\sqrt{3}}{3})$
 33 $\pi - \alpha, \pi - \beta, \pi - \gamma$ 34 $k(8\mathbf{i} + \mathbf{j} - 10\mathbf{k})$

Exercise 14.3

- 1 a) $k - \mathbf{j}$ b) same
 2 a) $\mathbf{i} - \mathbf{k}$ b) same
 3 a) $\mathbf{j} - \mathbf{i}$ b) same
 4 Proof 5 $(13, 0, 13)$ 6 $6\mathbf{i} - 8\mathbf{j} - 8\mathbf{k}$
 7 $\begin{pmatrix} -5 \\ -1 \\ -7 \end{pmatrix}$ 8 $\mathbf{i} + \mathbf{j} - 3\mathbf{k}$
 9 a) $-2m^2 + 9m - 11$ b) $-2m^2 + 9m - 11$
 c) $-2m^2 + 9m - 11$
 10 a) $(-40, -115, 30)$ b) $(-150, 60, 0)$
 c) $(-80, -160, -640)$
 d) $(80, 160, 640)$ e) $(-40, -115, 30)$
 f) $(-150, 60, 0)$
 11 $\frac{\sqrt{1774}}{1774} \begin{pmatrix} 19 \\ 33 \\ -18 \end{pmatrix}$ 12 $\frac{\sqrt{6}}{6} \begin{pmatrix} 2 \\ 1 \\ 1 \end{pmatrix}$ 13 $\sqrt{209}$
 14 $\sqrt{139}$ 15 $2\sqrt{43}$ 16 Proof
 17 $m = 1$ or $m = \frac{11}{4}$ 18 $\frac{\sqrt{374}}{2}$ 19 $5\sqrt{29}$
 20 128 21 21 22 1 23 78
 24 63 25 No 26 Yes 27 $-2, \frac{6}{5}$
 28 Not possible
 29 a) 49 b) $7\sqrt{5}$ c) $\frac{7\sqrt{5}}{5}$ d) $\cos^{-1}(\frac{7\sqrt{10}}{30})$
 30 a) $\frac{49}{3}$, $V(\text{tetrahedron}) = \frac{1}{3}V(\text{parallelepiped})$ b) $\frac{4}{3}$
 31 45° 32 Proof 33 Proof
 34 a) $\sqrt{\frac{564}{29}}$ b) $\frac{6\sqrt{5}}{5}$ c) $\sqrt{\frac{3}{2}}$
 35 $2(\mathbf{u} \times \mathbf{v})$ 36 $23(\mathbf{u} \times \mathbf{v})$ 37 $(mp + nq)(\mathbf{u} \times \mathbf{v})$
 38 a) $o = \frac{1}{2}(\sqrt{(ab)^2 + (ac)^2 + (bc)^2})$
 b) $a = \frac{1}{2}ab; b = \frac{1}{2}bc; c = \frac{1}{2}ac$
 c) result obvious

$$39 \begin{pmatrix} 5t - \frac{1}{3} \\ -t + \frac{2}{3} \\ 3t \end{pmatrix}$$

40 Not possible

Exercise 14.4

1 a) $\mathbf{r} = \begin{pmatrix} -1 \\ 0 \\ 2 \end{pmatrix} + t \begin{pmatrix} 1 \\ 5 \\ -4 \end{pmatrix}$ $\begin{pmatrix} x \\ y \\ z \end{pmatrix} = \begin{pmatrix} -1 + t \\ 5t \\ 2 - 4t \end{pmatrix}$

b) $\mathbf{r} = \begin{pmatrix} 3 \\ -1 \\ 2 \end{pmatrix} + t \begin{pmatrix} 2 \\ 5 \\ -1 \end{pmatrix}$ $\begin{pmatrix} x \\ y \\ z \end{pmatrix} = \begin{pmatrix} 3 + 2t \\ -1 + 5t \\ 2 - t \end{pmatrix}$

c) $\mathbf{r} = \begin{pmatrix} 1 \\ -2 \\ 6 \end{pmatrix} + t \begin{pmatrix} 3 \\ 5 \\ -11 \end{pmatrix}$ $\begin{pmatrix} x \\ y \\ z \end{pmatrix} = \begin{pmatrix} 1 + 3t \\ -2 + 5t \\ 6 - 11t \end{pmatrix}$

2 a) $\mathbf{r} = \begin{pmatrix} -1 \\ 4 \\ 2 \end{pmatrix} + t \begin{pmatrix} 8 \\ 1 \\ -2 \end{pmatrix}$ b) $\mathbf{r} = \begin{pmatrix} 4 \\ 2 \\ -3 \end{pmatrix} + t \begin{pmatrix} -4 \\ -4 \\ 4 \end{pmatrix}$

c) $\mathbf{r} = \begin{pmatrix} 1 \\ 3 \\ -3 \end{pmatrix} + t \begin{pmatrix} 4 \\ -2 \\ 5 \end{pmatrix}$

3 a) $\mathbf{r} = \begin{pmatrix} 3 \\ -2 \end{pmatrix} + t \begin{pmatrix} 2 \\ 3 \end{pmatrix}$ b) $\mathbf{r} = \begin{pmatrix} 0 \\ -2 \end{pmatrix} + t \begin{pmatrix} 5 \\ 2 \end{pmatrix}$

4 $2x + 3y = 7$

5 $\mathbf{r} = 2\mathbf{i} - 3\mathbf{j} + \lambda(4\mathbf{i} - 3\mathbf{j})$

6 $\mathbf{r} = (-2, 1, 4) + t(3, -4, 7)$

7 a) $(1, -1, 2)$ b) $(-17, -1, 1)$

c) No d) No

8 a) $\mathbf{r} = (2, -1) + t(1, 3)$ $\begin{pmatrix} x \\ y \end{pmatrix} = \begin{pmatrix} 2 + t \\ -1 + 3t \end{pmatrix}$

b) $\mathbf{r} = (2, -1) + t(-3, 7)$ $\begin{pmatrix} x \\ y \end{pmatrix} = \begin{pmatrix} 2 - 3t \\ -1 + 7t \end{pmatrix}$

c) $\mathbf{r} = (2, -1) + t(7, 3)$ $\begin{pmatrix} x \\ y \end{pmatrix} = \begin{pmatrix} 2 + 7t \\ -1 + 3t \end{pmatrix}$

d) $\mathbf{r} = (0, 2) + t(2, -4)$ $\begin{pmatrix} x \\ y \end{pmatrix} = \begin{pmatrix} 2t \\ 2 - 4t \end{pmatrix}$

9 a) $t = \frac{3}{2}$ b) no c) $m = \frac{7}{2}$

10 a) (i) $(3, -4)$ (ii) $(7, 24)$ (iii) 25

b) (i) $(-3, 1)$ (ii) $(5, -12)$ (iii) 13

c) (i) $(5, -2)$ (ii) $(24, -7)$ (iii) 25

11 a) $(-96, 128)$ b) $(\frac{2040}{13}, -\frac{850}{13})$

12 a) $(24, 18)$

b) $\mathbf{r} = (3, 2) + t(24, 18)$

c) In 10 minutes

13 a) $a = -3, b = -5$

b) $-\frac{\sqrt{21}}{6}$

c) $\frac{\sqrt{15}}{6}, \frac{\sqrt{35}}{2}$

14 a) 146.8° b) 3.87

c) (i) $L_1: \mathbf{r} = (2, -1, 0) + t(0, 1, 2); L_2: \mathbf{r} = (-1, 1, 1) + t(1, -3, -2)$

15 a) $(x, y, z) = (1 + t, 3 - 2t, -17 + 5t)$

b) $(4, -3, -2)$

16 a) $\mathbf{r} = \begin{pmatrix} p \\ m, 0 \end{pmatrix} + t(n, -m)$

b) (i) $bx - ay = bx_0 - ay_0$

(ii) slope = $\frac{b}{a}$

17 (i) $\mathbf{r} = (t, t, 3t), 0 \leq t \leq 1$

(ii) $\mathbf{r} = (2t - 1, t, 1 - 3t), 0 \leq t \leq 1$

(iii) $\mathbf{r} = (1 - t, 3t, t - 1), 0 \leq t \leq 1$

18 $\mathbf{r} = (2j + 3k) + 2tk$

$\begin{cases} x = 0 \\ y = 2 \\ z = 3 + 2t \end{cases}$

19 $\mathbf{r} = (i + 2j - k) + t(2i - 3j + k)$

$\begin{cases} 1 + 2t \\ 2 - 3t \\ -1 + t \end{cases}$

20 $\mathbf{r} = t(x_0\mathbf{i} + y_0\mathbf{j} + z_0\mathbf{k})$

$\begin{cases} tx_0 \\ ty_0 \\ tz_0 \end{cases}$

21 a) $\mathbf{r} = (3i + 2j - 3k) + tj$

$\begin{cases} 3 \\ 2 + t \\ -3 \end{cases}$

b) $\mathbf{r} = (3i + 2j - 3k) + ti$

$\begin{cases} 3 + t \\ 2 \\ -3 \end{cases}$

22 $\frac{x - x_0}{x_0} = \frac{y - y_0}{y_0} = \frac{z - z_0}{z_0}$

23 Intersect at $(1, 3, 1)$

24 Parallel

25 Skew lines

26 Skew lines

27 Parallel

28 Skew lines

29 $(4, -4, 8)$

30 $(\frac{16}{11}, \frac{35}{11}, \frac{13}{11})$ 31 $(\frac{17}{11}, -\frac{7}{11}, \frac{72}{11})$ 32 $(\frac{43}{11}, \frac{58}{11}, -\frac{1}{11})$

Exercise 14.5

1 B and C

2 A

3 $\begin{pmatrix} 2 \\ -4 \\ 3 \end{pmatrix} \begin{pmatrix} x \\ y \\ z \end{pmatrix} = 26; 2x - 4y + 3z - 26 = 0$

4 $\begin{pmatrix} 2 \\ 0 \\ 3 \end{pmatrix} \begin{pmatrix} x \\ y \\ z \end{pmatrix} = -3; 2x + 3z + 3 = 0$

5 $\begin{pmatrix} 0 \\ 0 \\ 3 \end{pmatrix} \begin{pmatrix} x \\ y \\ z \end{pmatrix} = 3; 3z - 3 = 0; \mathbf{r} = \begin{pmatrix} 0 \\ 3 \\ 1 \end{pmatrix} + t \begin{pmatrix} 2 \\ -1 \\ 0 \end{pmatrix} + s \begin{pmatrix} 1 \\ 1 \\ 0 \end{pmatrix}$

6 $\begin{pmatrix} 5 \\ 1 \\ -2 \end{pmatrix} \begin{pmatrix} x \\ y \\ z \end{pmatrix} = 5; 5x + y - 2z - 5 = 0$

7 $\begin{pmatrix} 0 \\ 1 \\ -2 \end{pmatrix} \begin{pmatrix} x \\ y \\ z \end{pmatrix} = -2; y - 2z + 2 = 0$



$$8 \quad \begin{pmatrix} 1 \\ -6 \\ 2 \end{pmatrix} \begin{pmatrix} x \\ y \\ z \end{pmatrix} = 23; r = \begin{pmatrix} 3 \\ -2 \\ 4 \end{pmatrix} + \lambda \begin{pmatrix} 2 \\ 1 \\ 2 \end{pmatrix} + \mu \begin{pmatrix} 2 \\ 0 \\ -1 \end{pmatrix}$$

$$9 \quad \begin{pmatrix} -2 \\ 2 \\ 1 \end{pmatrix} \begin{pmatrix} x \\ y \\ z \end{pmatrix} = -1; -2x + 2y + z = -1$$

$$10 \quad \begin{pmatrix} 18 \\ -3 \\ -11 \end{pmatrix} \begin{pmatrix} x \\ y \\ z \end{pmatrix} = 5; 18x - 3y - 11z = 5$$

$$11 \quad \begin{pmatrix} p \\ q \\ r \end{pmatrix} \begin{pmatrix} x \\ y \\ z \end{pmatrix} = p^2 + q^2 + r^2; px + qy + rz = p^2 + q^2 + r^2$$

$$12 \quad 4x - 2y + 7z = 14; \begin{pmatrix} 4 \\ -2 \\ 7 \end{pmatrix} \begin{pmatrix} x \\ y \\ z \end{pmatrix} = 14;$$

$$r = \begin{pmatrix} 1 \\ 2 \\ 2 \end{pmatrix} + m \begin{pmatrix} 2 \\ -3 \\ -2 \end{pmatrix} + n \begin{pmatrix} 4 \\ 1 \\ -2 \end{pmatrix}$$

$$13 \quad 8x + 17y - 5z + 8 = 0; \begin{pmatrix} 8 \\ 17 \\ -5 \end{pmatrix} \begin{pmatrix} x \\ y \\ z \end{pmatrix} = -8;$$

$$r = \begin{pmatrix} 2 \\ -2 \\ -2 \end{pmatrix} + s \begin{pmatrix} 1 \\ 1 \\ 5 \end{pmatrix} + t \begin{pmatrix} -3 \\ 2 \\ 2 \end{pmatrix}$$

$$14 \quad \begin{pmatrix} 1 \\ -1 \\ 0 \end{pmatrix} \begin{pmatrix} x \\ y \\ z \end{pmatrix} = 3; x - y = 3$$

$$15 \quad \begin{pmatrix} 30 \\ 1 \\ -23 \end{pmatrix} \begin{pmatrix} x \\ y \\ z \end{pmatrix} = -86; 30x + y - 23z + 86 = 0$$

$$16 \quad \begin{pmatrix} 1 \\ 0 \\ -1 \end{pmatrix} \begin{pmatrix} x \\ y \\ z \end{pmatrix} = 1; x - z = 1; r = \begin{pmatrix} 1 \\ 1 \\ 0 \end{pmatrix} + m \begin{pmatrix} 1 \\ 0 \\ 1 \end{pmatrix} + n \begin{pmatrix} 1 \\ -1 \\ 1 \end{pmatrix}$$

Note: All answers for 17–22 are to the nearest degree.

17 64° 18 90° 19 45° 20 50°
 21 24° 22 55° 23 $(3, 6, -10)$ 24 $(2, -2, 6)$

25 No intersection 26 Plane contains line

$$27 \quad r = \begin{pmatrix} 10 \\ -7 \\ 0 \end{pmatrix} + t \begin{pmatrix} 0 \\ -1 \\ 1 \end{pmatrix} \quad 28 \quad r = \begin{pmatrix} 3 \\ 1 \\ 0 \end{pmatrix} + t \begin{pmatrix} 0 \\ 1 \\ 1 \end{pmatrix}$$

29 No intersection

$$30 \quad r = \begin{pmatrix} \quad \\ \quad \\ \quad \end{pmatrix} + t \begin{pmatrix} 0 \\ -1 \\ 1 \end{pmatrix} \quad 31 \quad \begin{pmatrix} 1 \\ -1 \\ 1 \end{pmatrix} \begin{pmatrix} x \\ y \\ z \end{pmatrix} = 0$$

$$32 \quad x + 6y + z = 16 \quad 33 \quad \begin{pmatrix} 31 & 37 & 85 \\ 21 & 21 & 21 \end{pmatrix}$$

$$34 \quad \begin{pmatrix} 10 \\ 1 \\ -8 \end{pmatrix} \begin{pmatrix} x \\ y \\ z \end{pmatrix} = -32; 10x + y - 8z + 32 = 0$$

$$35 \quad \begin{pmatrix} 4 \\ -3 \\ 2 \end{pmatrix} \begin{pmatrix} x \\ y \\ z \end{pmatrix} = 5; 4x - 3y + 2z - 5 = 0$$

36 $(BC)x + (AC)y + (AB)z = ABC$

$$37 \quad r = \begin{pmatrix} 4 \\ -3 \\ -1 \end{pmatrix} + r \begin{pmatrix} 2 \\ -3 \\ 4 \end{pmatrix} + s \begin{pmatrix} 4 \\ 0 \\ -3 \end{pmatrix}$$

$$38 \quad r = \begin{pmatrix} 2 \\ 3 \\ 0 \end{pmatrix} + m \begin{pmatrix} 2 \\ -3 \\ 4 \end{pmatrix} + n \begin{pmatrix} 1 \\ -2 \\ 1 \end{pmatrix}$$

Practice questions

1 a) $\overrightarrow{OD} - \overrightarrow{OC}$ b) $\frac{1}{2}(\overrightarrow{OD} - \overrightarrow{OC})$ c) $\frac{1}{2}(\overrightarrow{OD} + \overrightarrow{OC})$

2 a) $5\mathbf{i} + 12\mathbf{j}$ b) $10\mathbf{i} + 24\mathbf{j}$

3 a) $|\overrightarrow{OA}| = |\overrightarrow{OB}| = |\overrightarrow{OC}| = 6$

b) $\overrightarrow{AC} = \begin{pmatrix} -1 \\ \sqrt{11} \end{pmatrix}$ c) $\frac{1}{\sqrt{12}}$ d) $6\sqrt{11}$

4 a) $(10, 5)$ b) $(-3, 6); 90^\circ$

5 $a = 2, b = 8$

6 $r = (3, -1) + t(4, -5)$

7 a) 39.4 b) (i) $(9, 12), (18, -8)$ (ii) $\sqrt{481}$

c) 7 a.m. d) 24.4 km e) 54 minutes

8 $r = t(2\mathbf{i} + 3\mathbf{j})$

9 b) $(2, 3.25)$

10 c) 90°

d) (i) $12x - 5y = 301$ (ii) $(28, 7)$

11 117°

12 $2x + 3y = 5$

13 a) $(6, 20)$ b) (i) $(6, -8)$ (ii) 10

c) $4x + 3y = 84$

f) 26 km

14 72°

15 a) 3.94 m

c) $x - 0.7y = 2$

e) Speed = 1.24 m/s

b) 1.22 m/s

d) $\begin{pmatrix} 170 & 160 \\ 29 & 29 \end{pmatrix}$

16 $\begin{pmatrix} x \\ y \end{pmatrix} = \begin{pmatrix} 1 \\ 3 \end{pmatrix} + t \begin{pmatrix} 5 \\ 2 \end{pmatrix}$

17 $2x^2 + 7x - 15 = 0, x = \frac{3}{2}, x = -5$

18 a) (ii) $(288, 84)$ (iii) 50 minutes b) 20.6°

c) (i) $(99, 168)$ (iii) $XY = 75$ d) 180 km

19 $3x + 2y = 7$

20 a) $\overrightarrow{ST} = \begin{pmatrix} 9 \\ 9 \end{pmatrix}, V(-4, 6)$ b) $r = (-4, 6) + \lambda(1, 1)$

c) $\lambda = 5$

d) (i) $a = 5$ (ii) 157°

21 81.9°

22 a) 13

b) $\frac{1}{5}(3\mathbf{i} + 4\mathbf{j})$

c) $\frac{56}{65}$

23 $(2, 3)$

24 a) $(3, -2)$

c) (iii) 23 square units

25 a) $\overrightarrow{OB} = \begin{pmatrix} -1 \\ 7 \end{pmatrix}; \overrightarrow{OC} = \begin{pmatrix} 8 \\ 9 \end{pmatrix}$ b) $d = 11$

c) $\overrightarrow{BD} = \begin{pmatrix} 12 \\ -3 \end{pmatrix}$ d) (i) $\begin{pmatrix} x \\ y \end{pmatrix} = \begin{pmatrix} -1 \\ 7 \end{pmatrix} + t \begin{pmatrix} 12 \\ -3 \end{pmatrix}$ (ii) $t = 0$

26 a) (i) $\overrightarrow{AB} = \begin{pmatrix} -5 \\ 1 \end{pmatrix}$ (ii) $AB = \sqrt{26}$ b) $\overrightarrow{AD} = \begin{pmatrix} d-2 \\ 25 \end{pmatrix}$

c) (ii) $\overrightarrow{OD} = \begin{pmatrix} 7 \\ 23 \end{pmatrix}$ d) $\overrightarrow{OC} = \begin{pmatrix} 2 \\ 24 \end{pmatrix}$ e) 130

27 a) (i) $\overrightarrow{BC} = -6\mathbf{i} - 2\mathbf{j}$ (ii) $\overrightarrow{OD} = -2\mathbf{i}$ b) 82.9°

c) $r = \mathbf{i} - 3\mathbf{j} + t(2\mathbf{i} + 7\mathbf{j})$ d) $15\mathbf{i} + 46\mathbf{j}$

28 a) $(5, 5, -5)$ b) $(-5, 0, 5)$ c) $(5, 5, -5)$

29 b) (i) $(49, 32, 0)$ (ii) 54 km/h

c) (i) $\frac{5}{6}$ hours (ii) $(9, 12, 5)$

30 a) (i) $\overrightarrow{AB} = \begin{pmatrix} 800 \\ 600 \end{pmatrix}$

b) (ii) $\begin{pmatrix} -400 \\ -50 \end{pmatrix}$ (iii) at 16:00 hours

c) 27.8 km

31 a) $c = 1$

b) $3\mathbf{i} + 3\mathbf{k}$

c) $r = 3(1-t)\mathbf{i} + (3-t)\mathbf{j} + (5+3t)\mathbf{k}$

- d) $9x - 15y + 4z - 2 = 0$
- 32 a) $\overline{AB} = -i - 3j + k; \overline{BC} = i + j$
 b) $-i + j + 2k$
 c) $\frac{\sqrt{6}}{2}$
 d) $-x + y + 2z = 3$
 e) $\begin{cases} 2-t \\ -1+t \\ -6+2t \end{cases}$
 f) $3\sqrt{6}$
 g) $\frac{1}{\sqrt{6}}(-i + j + 2k)$
 h) $E(-4, 5, 6)$
- 33 Proof
- 34 a) $P(4, 0, -3), Q(3, 3, 0), R(3, 1, 1), S(5, 2, 1)$
 b) $3x + 2y + 4z = 0$
 c) 0
- 35 a) 147° b) 2.29
 c) (i) $L_1: \begin{cases} 2 \\ -1 + \lambda; \\ 2\lambda \end{cases}; L_2: \begin{cases} -1 + \mu \\ 1 - 3\mu \\ 1 - 2\mu \end{cases}$ (ii) no solution
 d) $\frac{9}{\sqrt{21}}$
- 36 a) $(1, -1, 2)$
 b) $11i - 7j - 5k$
 c) $\mathbf{v} \cdot \mathbf{u} = 0$
 d) $\mathbf{r} = \begin{pmatrix} 1 \\ -1 \\ 2 \end{pmatrix} + t \begin{pmatrix} 6 \\ 13 \\ -5 \end{pmatrix}$
- 37 a) (i) $-5i + 3j + k$ (ii) $\frac{\sqrt{35}}{2}$
 b) (i) $-5x + 3y + z = 5$
 (ii) $\frac{x-5}{-5} = \frac{y+2}{3} = z-1$
 c) $(0, 1, 2)$ d) $\sqrt{35}$
- 38 a) $x - 2 = y - 5 = z + 1$ b) $(\frac{1}{3}, \frac{10}{3}, -\frac{8}{3})$
 c) $A'(-\frac{4}{3}, \frac{5}{3}, -\frac{13}{3})$ d) $\frac{\sqrt{654}}{3}$
- 39 a) $3x - 4y + z = 6$
 b) (ii) $\mathbf{r} = \begin{pmatrix} 1 \\ 2 \\ 11 \end{pmatrix} + t \begin{pmatrix} 1 \\ 4 \\ 13 \end{pmatrix}$ c) 53.7°
- 40 a) $(3\mu - 2, \mu, 9 - 2\mu)$
 b) (i) $\mathbf{r} = \begin{pmatrix} 4 \\ 0 \\ -3 \end{pmatrix} + \lambda \begin{pmatrix} 3 \\ 1 \\ -2 \end{pmatrix}$
 (ii) $\overrightarrow{PM} = \begin{pmatrix} 3\mu - 6 \\ \mu \\ 12 - 2\mu \end{pmatrix}$
 c) (i) $\mu = 3$ (ii) $3\sqrt{6}$
 d) $2x - 4y + z = 5$ e) verify
- 41 a) $(1, -1, 2)$
 b) $2x - y + z = 5$
 c) $(3, 1, 3)$ and $(1, 2, 2)$
- 42 a) (i) $\lambda = \mu$
 (ii) $\mathbf{r} = \begin{pmatrix} 2 \\ 1 \\ 1 \end{pmatrix} + t \begin{pmatrix} -1 \\ -2 \\ -1 \end{pmatrix}$
 b) $3x - 2y + z = 5$
 c) $\mathbf{r} = \begin{pmatrix} 2 \\ 1 \\ 1 \end{pmatrix} + t \begin{pmatrix} -1 \\ -2 \\ -1 \end{pmatrix}$

Chapter 15

Exercise 15.1

- 1 a) $y' = 12(3x - 8)^3$ b) $y' = -\frac{1}{2\sqrt{1-x}}$
 c) $y' = \cos^2 x - \sin^2 x$
 d) $y' = \cos\left(\frac{x}{2}\right)$ e) $y' = -\frac{4x}{(x^2 + 4)^3}$
 f) $y' = \frac{-2}{(x-1)^2}$
 g) $y' = \frac{-1}{2\sqrt{(x+2)^3}}$ [or $\frac{-1}{(2x+4)\sqrt{x+2}}$]
 h) $y' = -2 \sin x \cos x$
 i) $y' = \frac{-x+2}{2\sqrt{(1-x)^3}}$ [or $\frac{-x+2}{(2-2x)\sqrt{1-x}}$]
 j) $y' = \frac{-6x+5}{(3x^2-5x+7)^2}$ k) $y' = \frac{2}{3\sqrt{(2x+5)^2}}$
 l) $y' = 2(2x-1)^2(7x^4-2x^3+3)$
- 2 a) $y = -12x - 11$ b) $y = \frac{9}{5}x - \frac{2}{5}$
 c) $y = 2x - 2\pi$ d) $y = \frac{1}{2}x + \frac{1}{2}$
- 3 a) $v(t) = -2t \sin(t^2 - 1)$ b) velocity = 0
 c) $t = \sqrt{\pi + 1} \approx 2.04, t = 1$
 d) Accelerating to the right then slowing down, turning around, accelerating to the left, slowing down, turning around again, then accelerating to the right.
- 4 a) $y = -12x + 38$ b) $y = \frac{1}{12}x + \frac{7}{4}$
 5 a) $y = \frac{2}{3}x + \frac{5}{3}$ b) $y = -\frac{3}{2}x + 6$
 6 a) $y = \frac{1}{4}x + \frac{1}{4}$ b) $y = -4x + \frac{9}{2}$
 7 a) $\frac{dy}{dx} = 2 \sin(2x); \frac{d^2y}{dx^2} = 4 \cos(2x)$
 b) $(\frac{\pi}{4}, 0)$ and $(\frac{3\pi}{4}, 0)$
- 8 a) (i) $(0, 0)$ and $(4, 0)$ (ii) $(\frac{4}{3}, \frac{256}{27})$ (iii) $(\frac{8}{3}, \frac{128}{27})$

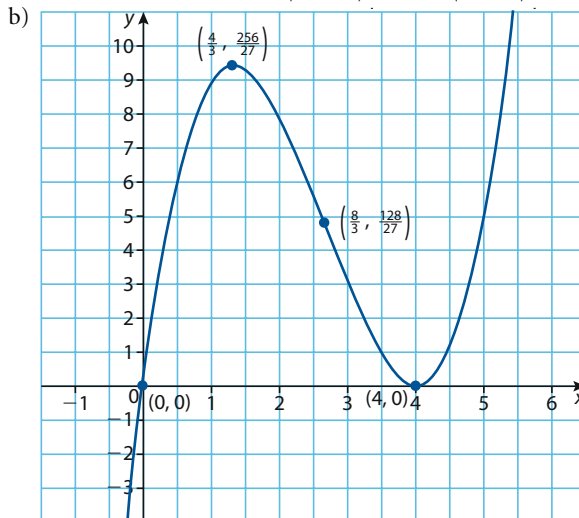

- 9 c) $f''(3.8) = 0$ and $f''(3) = \frac{1}{3} > 0$, $f''(4) = -\frac{2}{625} < 0$,
therefore graph of f changes concavity from up to down
at $x = 3.8$ verifying that graph of f does have an inflexion
point at $x = 3.8$

10 $\frac{dy}{dx} = \frac{2a}{(x+a)^2}$; $\frac{d^2y}{dx^2} = \frac{-4a}{(x+a)^3}$

11 $\frac{d^n y}{dx^n} = \frac{(-1)^{n+1} n!}{(x-1)^{n+1}}$ (or $-\frac{n!}{(1-x)^{n+1}}$)

- 12 a) Max. at $(0, 2)$; inflexion pts at or $(-2, 1)$ and $(2, 1)$
b) (i) None (ii) none (iii) all $x \in \mathbb{R}$
c) (i) $\lim_{x \rightarrow \infty} g(x) = 0$ (ii) $\lim_{x \rightarrow -\infty} g(x) = 0$

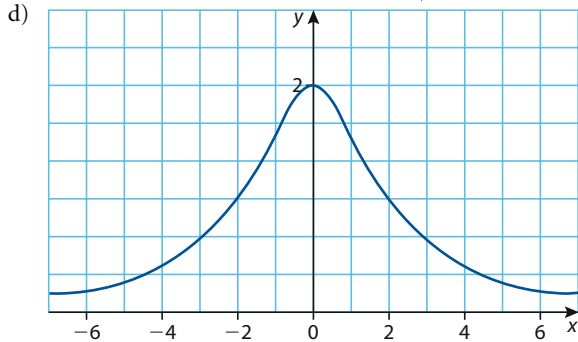

13 $\frac{d}{dx}(c \cdot f(x)) = \frac{d}{dx}(c) \cdot f(x) + c \cdot \frac{d}{dx}(f(x))$
 $= 0 \cdot f(x) + c \cdot \frac{d}{dx}(f(x)) = c \cdot \frac{d}{dx}(f(x))$

- 14 $y = x^2(x^2 - 6) = 0$ when $x = 0$ and $x = \pm\sqrt{6}$;
 $y\left(\frac{1}{2}\right) = -\frac{23}{16} < 0$, so $y < 0$ for $0 < x < 1$
 $\frac{dy}{dx} = 4x(x^2 - 3) = 0$ when $x = 0$, $x = \pm\sqrt{3}$; when
 $x = \frac{1}{2}$, $\frac{dy}{dx} = -\frac{11}{2} < 0$, so $\frac{dy}{dx} < 0$ for $0 < x < 1$
 $\frac{d^2y}{dx^2} = 12(x^2 - 1) = 0$ when $x = 0$, $x = \pm 1$; when
 $x = \frac{1}{2}$, $\frac{d^2y}{dx^2} = -9 < 0$, so $\frac{d^2y}{dx^2} < 0$ for $0 < x < 1$
 $\frac{d^3y}{dx^3} = 24x > 0$ for $0 < x < 1$

Exercise 15.2

- 1 a) $y' = x^2 e^x + 2x e^x$ b) $y' = 8^x \ln 8$
c) $y' = e^x \sec^2(e^x)$ d) $y' = \frac{\cos x + x \sin x + 1}{(1 + \cos x)^2}$
e) $y' = \frac{x e^x - e^x}{x^2}$ f) $y' = 2 \tan^3(2x) \sec(2x)$
g) $y' = \left(\frac{1}{4}\right)^x \ln\left(\frac{1}{4}\right)$ h) $y' = \cos x$
i) $y' = \frac{-x e^x + e^x - 1}{(e^x - 1)^2}$ j) $y' = -12 \cos(3x) \sin(\sin(3x))$
k) $y' = 2 \ln 2 (2^x)$ l) $y' = \frac{\cos^3 x - \sin^3 x}{(\cos x - \sin x)^2}$

2 a) $y = \frac{1}{2}x + \frac{3\sqrt{3} - \pi}{6}$

b) $y = 2x + 1$

c) $y = 16x + 4 - 2\pi$

3 a) $x = \frac{\pi}{6}$, $x = \frac{5\pi}{6}$

b) Maximum at $\frac{\pi}{6}$, minimum at $\frac{5\pi}{6}$

4 $(0, -1)$ is an absolute maximum

5 a) Maximum at $\left(\frac{\pi}{2}, 5\right)$; minimum at $\left(\frac{3\pi}{2}, -3\right)$

b) Minimum at $\left(\frac{3\pi}{4}, -1\right)$ and $\left(\frac{7\pi}{4}, -1\right)$

6 $x = \frac{\pi}{2}$

7 a) $f'(x) = e^x - 3x^2$; $f''(x) = e^x - 6x$

b) $x \approx 3.73$ or $x \approx 0.910$ or $x \approx -0.459$

c) Decreasing on $(-\infty, -0.459)$ and $(0.910, 3.73)$;
increasing on $(-0.459, 0.910)$ and $(3.73, \infty)$

d) $x \approx -0.459$ (minimum); $x \approx 0.910$ (maximum);
 $x \approx 3.73$ (minimum)

e) $x \approx 0.204$ or $x \approx 2.83$

f) Concave up on $(-\infty, 0.204)$ and $(2.83, \infty)$; concave down
on $(0.204, 2.83)$

- 8 The two functions intersect for all x such that
 $\cos x = 1$, i.e. $x = k \cdot 2\pi$, $k \in \mathbb{Z}$. The derivatives for the
two functions are $y' = -e^{-x}$ and $y' = -e^{-x}(\cos x + \sin x)$.
The derivatives are equal whenever $x = k \cdot 2\pi$, $k \in \mathbb{Z}$.
Therefore, the functions are tangent at all of the intersection
points.

9 a) 8 ms^{-2} b) 2.09 ms^{-1}

10 $y = ex$

11 a) $f'(x) = 2^x \ln 2$

b) $y = x \ln 2 + 1$

c) $f'(x) = 2^x \ln 2 \neq 0$ for any x

12 a) $(-1, -2e)$ and $\left(3, \frac{6}{e^3}\right)$

b) $(-1, -2e)$ is a minimum; $\left(3, \frac{6}{e^3}\right)$ is a maximum

c) (i) $\lim_{x \rightarrow \infty} h(x) = 0$

(ii) as $x \rightarrow -\infty$, $h(x)$ increases without bound

d) Horizontal asymptote $y = 0$

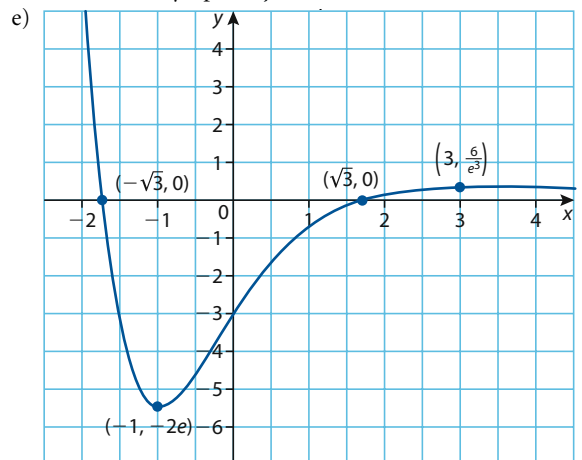

- 13 a) $a = \frac{\pi}{2}, b = \pi, c = \frac{3\pi}{2}$
 b) $\frac{d^{(n)}}{dx^{(n)}}(\sin x) = \sin\left(x + n \cdot \frac{\pi}{2}\right), n \in \mathbb{Z}^+$
 14 a) $\frac{d}{dx}(xe^x) = xe^x + e^x; \frac{d^2}{dx^2}(xe^x) = xe^x + 2e^x;$
 $\frac{d^3}{dx^3}(xe^x) = xe^x + 3e^x$
 b) $\frac{d^{(n)}}{dx^{(n)}}(xe^x) = xe^x + ne^x$

Exercise 15.3

- 1 $\frac{dy}{dx} = -\frac{x}{y}$ 2 $\frac{dy}{dx} = \frac{-2xy - y^2}{x^2 + 2xy}$
 3 $\frac{dy}{dx} = \cos^2 y$ [or $\frac{dy}{dx} = \frac{1}{1+x^2}$]
 4 $\frac{dy}{dx} = \frac{-2x + 3y^2 - y^3}{-6xy + 3xy^2 - 2y}$ 5 $\frac{dy}{dx} = \frac{x^2y + y^3}{x^3 + xy^2}$
 6 $\frac{dy}{dx} = \frac{-2xy - 2y^2 - xy}{2x^2 + 2xy + xy}$ 7 $\frac{dy}{dx} = \frac{y-1}{\cos y - x}$
 8 $\frac{dy}{dx} = \frac{4x^3 - 2xy^3}{3x^2y^2 + 4y^3}$ 9 $\frac{dy}{dx} = \frac{-y}{x + e^y}$
 10 $\frac{dy}{dx} = \frac{x+2}{y+3}$
 11 $\frac{dy}{dx} = -\sin^2(x+y)$ [or $\frac{dy}{dx} = -\frac{x^2}{x^2+1}$]
 12 $\frac{dy}{dx} = \frac{18x^2\sqrt{xy} - y}{x + 2\sqrt{xy}}$
 13 $y = -\frac{7}{5}x + \frac{4}{5}; y = \frac{5}{7}x - \frac{24}{7}$
 14 $y = -2x + 4; y = \frac{1}{2}x + \frac{3}{2}$
 15 $y = -\frac{\pi}{2}x + \pi; y = \frac{2}{\pi}x + \frac{\pi^2 - 4}{2\pi}$
 16 $y = -\frac{352}{23}x - \frac{32}{23}; y = \frac{23}{352}x - \frac{5655}{176}$
 17 $x^2 + y^2 = r^2 \Rightarrow \frac{dy}{dx} = -\frac{x}{y}$; at point $(x_1, y_1), m = -\frac{x_1}{y_1}$;
 centre of circle is $(0,0)$; slope of line through (x_1, y_1)
 and $(0,0)$ is $\frac{y_1}{x_1}$; because $-\frac{x_1}{y_1} \times \frac{y_1}{x_1} = -1$, the tangent to the
 circle at (x_1, y_1) and the line through (x_1, y_1) and $(0,0)$ are
 perpendicular
 18 a) $(\sqrt{7}, 0), (-\sqrt{7}, 0); \frac{dy}{dx} = \frac{-2x - y}{x + 2y}$, at both points
 $\frac{dy}{dx} = -2$
 b) $\left(\sqrt{\frac{7}{3}}, -2\sqrt{\frac{7}{3}}\right)$ and $\left(-\sqrt{\frac{7}{3}}, 2\sqrt{\frac{7}{3}}\right)$
 c) $\left(2\sqrt{\frac{7}{3}}, -\sqrt{\frac{7}{3}}\right)$ and $\left(-2\sqrt{\frac{7}{3}}, \sqrt{\frac{7}{3}}\right)$
 19 $(0,0)$
 20 $\frac{dy}{dx} = -\frac{4x}{9y}, \frac{d^2y}{dx^2} = \frac{-36y^2 - 16x^2}{81y^3}$
 21 $\frac{dy}{dx} = \frac{2-y}{(x+3)^2}, \frac{d^2y}{dx^2} = \frac{2y-4}{(x+3)^2}$
 22 a) $\frac{dy}{dx} = \frac{-1}{3x^{\frac{4}{3}}}, \frac{d^2y}{dx^2} = \frac{4}{9x^{\frac{7}{3}}}$
 b) $\frac{dy}{dx} = -\frac{y}{3x}, \frac{d^2y}{dx^2} = \frac{4y}{9x^2}$

- 23 $y = x + \frac{1}{2}$ 24 $\frac{dy}{dx} = \frac{3x^2}{x^3+1}$
 25 $\frac{dy}{dx} = \cot x$ 26 $\frac{dy}{dx} = \frac{x}{(x^2-1)\ln 5}$
 27 $\frac{dy}{dx} = \frac{-1}{x^2-1}$ 28 $\frac{dy}{dx} = \frac{1}{2x \ln 10 \sqrt{\log x}}$
 29 $\frac{dy}{dx} = \frac{2a}{x^2-a}$ 30 $\frac{dy}{dx} = -\sin x$
 31 $\frac{dy}{dx} = \frac{-1}{x \ln 3 (\log_3 x)^2}$ 32 $\frac{dy}{dx} = \ln x$
 33 0 34 $y = \left(\frac{1}{8 \ln 2}\right)x - \frac{1}{\ln 2} + 3$

35 Verify

- 36 $x = \frac{1}{e^{\frac{3}{2}}}$
 37 a) $g'(x) = \frac{1 - \ln x}{x^2}, g''(x) = \frac{-3 + 2 \ln x}{x^3}$
 b) $g'(x) = 0$ only at $x = e$; $g''(e) = -\frac{1}{e^3} < 0, \therefore$ abs. max.
 at $x = e$, max. value of g is $\frac{1}{e}$
 38 $\frac{dy}{dx} = \frac{1}{x^2 + 2x + 2}$ 39 $\frac{dy}{dx} = \frac{1}{x^2 + 1}$
 40 $\frac{dy}{dx} = \frac{6}{x\sqrt{x^4 - 9}}$ 41 $\frac{dy}{dx} = \left(\tan^{-1}x + \frac{x}{x^2 + 1}\right)e^{x \tan^{-1}x}$
 42 $f'(x) = 0$; the graph of $f(x)$ is horizontal
 43 Verify
 44 $y = \left(\frac{\pi + 4}{2}\right)x + \frac{\pi - 4}{4}$
 45 a) For $0 \leq x < \pi, f'(x) = -1$, therefore $f(x)$ is linear
 b) $y = -x + \frac{\pi}{2}$
 46 $\sqrt{10} \approx 3.16$ m
 47 a) $\frac{1}{4} \text{ m s}^{-1}, \frac{1}{20} \text{ m s}^{-1}$
 b) $-\frac{1}{4} \text{ m s}^{-2}, -\frac{13}{800} \text{ m s}^{-2}$
 c) The particle initially is moving very fast to the right and then gradually slows down while continuing to move to the right.
 d) $\lim_{t \rightarrow \infty} s(t) = \frac{\pi}{2}$ m

Exercise 15.4

- 1 a) -18.1 cm/min b) -6.79 cm/min
 2 a) 0.298 cm/sec b) 0.439 cm/sec
 3 a) 2π cm/hr b) 8π cm/hr
 4 $\frac{d\theta}{dt} = \frac{3}{34} \approx 0.0882$ radians/min 5 26.4 m/sec
 6 2 ft/sec 7 69.6 km/hr
 8 $\frac{dy}{dt} = \frac{12}{\sqrt{10}} \approx 3.79$ 9 0.01 m/sec
 10 30 mm³/sec 11 45 km/hr
 12 $\frac{8\sqrt{3}}{3} \approx 4.62$ cm/sec 13 1.5 units/sec
 14 222.2 m/sec = 800 km/hr
 15 a) 115 degrees/sec b) 57 degrees/sec
 16 -485 km/hr

Exercise 15.5

- 1 $\sqrt{2}$ by $\frac{\sqrt{2}}{2}$
 2 $13\frac{1}{3}$ cm by $6\frac{2}{3}$ cm

- 3 $\frac{\sqrt{5}}{2}$
- 4 b) $S = 4x^2 + \frac{3000}{x}$ c) $7.21 \text{ cm} \times 14.4 \text{ cm} \times 9.61 \text{ cm}$
- 5 $x = 5\sqrt{2\pi} \approx 12.5 \text{ cm}$ 6 $x \approx 3.62 \text{ m}$
- 7 Longest ladder $\approx 7.02 \text{ m}$ 8 $d \approx 2.64 \text{ km}$
- 9 $\frac{8}{5}$ units² 10 6 nautical miles
- 11 $h = R\sqrt{2}$, $r = \frac{R\sqrt{2}}{2}$
- 12 Distance of point P from point X is $\frac{ac}{\sqrt{r^2 - c^2}}$
- 13 $x \approx 51.3 \text{ cm}$, maximum volume $\approx 403 \text{ cm}^3$

Practice questions

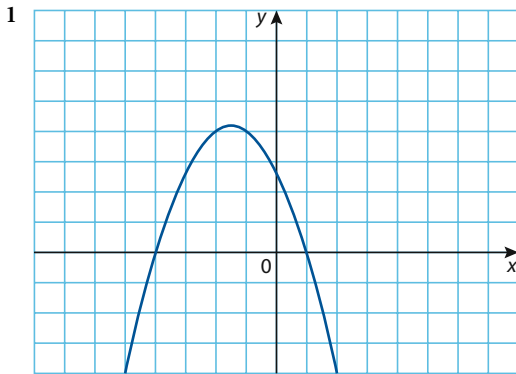

- 2 a) (i) $a = -4$ (ii) $b = 2$
 (i) $f'(x) = -3x^2 - 4x + 8$
 (ii) $\frac{-2 + 2\sqrt{7}}{3}$, $\frac{-2 - 2\sqrt{7}}{3}$
 (iii) $f(1) = 5$
- 3 a) (i) $y = 8x$ (ii) $x = -2$
- 3 a) (i) $v(0) = 0$ (ii) $v(10) \approx 51.3$
 b) (i) $a(t) = 0.99e^{-0.15t}$ (ii) $a(0) = 0.99$
 c) (i) 66 (ii) 0
 (iii) As object falls it approaches terminal velocity
- 4 a) $\left(-\frac{2}{3}, -\frac{149}{27}\right)$ is a minimum, $(-4, 13)$ is a maximum
 b) $\left(-\frac{7}{3}, \frac{101}{27}\right)$ is an inflexion point
- 5 a) (i) $g'(x) = -\frac{3}{e^{3x}}$
 (ii) $e^{3x} > 0$ for all x , hence $-\frac{3}{e^{3x}} < 0$ for all x ; therefore, $f(x)$ is decreasing for all x
 b) (i) $e + 2$
 (ii) $g'(-\frac{1}{3}) = -3e$
 c) $y = -3ex + 2$
- 6 b) $f'(3) = 0$ and $f''(3) > 0 \Rightarrow$ stationary point at $x = 3$ and graph of f is concave up at $x = 3$, so $f(3)$ is a minimum
 c) $(4, 0)$
- 7 a) $-\frac{4}{(2x+3)^3}$
 b) $5 \cos(5x)e^{\sin(5x)}$
- 8 $A = 1, B = 2, C = 1$
- 9 $\frac{dy}{dx} = -1$, $\frac{d^2y}{dx^2} = -4$
- 10 a) $\frac{dy}{dx} = \frac{-xe^x + e^x - 1}{(e^x - 1)^2}$
- b) $\frac{dy}{dx} = 2e^x \cos(2x) + e^x \sin(2x)$
- c) $\frac{dy}{dx} = 2x \ln x + 2x \ln 3 + x - \frac{1}{x}$
- 11 $y = -\frac{1}{2}x - \frac{3}{2}$, $P(-3, 0)$, $Q(0, -\frac{3}{2})$
- 12 a) $x = 3$; sign of $h''(x)$ changes from negative (concave down) to positive (concave up) at $x = 3$
 b) $x = 1$; $h'(x)$ changes from positive (h increasing) to negative (h decreasing) at $x = 1$
- 13 $y = \frac{5}{7}x + \frac{11}{7}$
- 14 $h = 8 \text{ cm}, r = 4 \text{ cm}$
- 15 Maximum area is 32 square units; dimensions are 4 by 8
- 16 a) E b) A c) C
- 17 $y = -\frac{1}{5}x + \frac{32}{5}$
- 18 a) $y = 4x - 4$
 b) $y = -\frac{1}{4}x + \frac{1}{4}$
- 19 a) Absolute minimum at $\left(\frac{1}{\sqrt{e}}, -\frac{1}{2e}\right)$
 b) Inflexion point at $\left(\frac{1}{\sqrt{e^3}}, -\frac{3}{2e^3}\right)$
- 20 a) (i) $a = 16$ (ii) $a = 54$
 b) $f'(x) = 2x - \frac{a}{x^2} = 0 \Rightarrow x = \sqrt[3]{\frac{a}{2}}$;
 $f''(x) = 2 + \frac{2a}{x^3} \Rightarrow f''\left(\sqrt[3]{\frac{a}{2}}\right) = 4 > 0$; hence, f is concave up at any critical point, so it cannot be a maximum
- 21 $y = -\frac{2}{3}x + 4$
- 22 $y = \left(\frac{\pi+2}{2}\right)x - \frac{\pi^2}{8}$; $y = \left(\frac{-2}{\pi+2}\right)x + \frac{\pi}{2\pi+4} + \frac{\pi}{4}$
- 23 a) Maximum at $\left(0, \frac{1}{\sqrt{2\pi}}\right)$; inflexion points at $\left(-1, \frac{1}{\sqrt{2e\pi}}\right)$ and $\left(1, \frac{1}{\sqrt{2e\pi}}\right)$
 b) $\lim_{x \rightarrow \pm\infty} f(x) = 0$; $y = 0$ (x -axis) is a horizontal asymptote
 c)

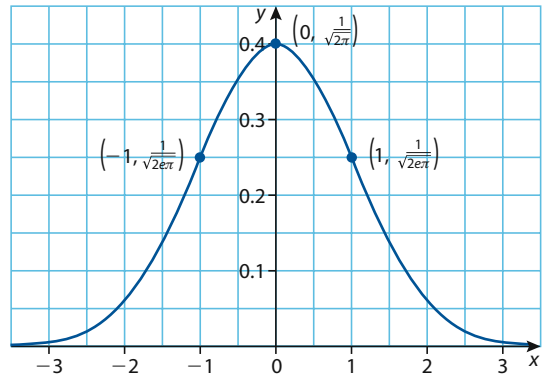

- 24 a) Min. at $x = 1$ because $f''(1) = \frac{1}{2} > 0$; max. at $x = 3$ because $f''(3) = -\frac{1}{6} < 0$
 b) Inflexion points at $x = -\sqrt{3}$ and $x = \sqrt{3}$ because $f''(x)$ changes sign at both values

25 $x = 20\sqrt{3} \approx 34.6$ km/hr 26 $\frac{dy}{dx} = \frac{5}{6}$ or $\frac{dy}{dx} = -\frac{5}{6}$

27 $\frac{dy}{dx} = \frac{-2x}{2x^4 - 2x^2 + 1}$ 28 $\frac{dy}{dx} = 2x \ln x + x$

29 $\sin x = \frac{1}{2}$, $\sin x = -1$ 30 $-\frac{3}{4}$

31 a) $f'(x) = \frac{2}{2x-1}$ b) $x = \frac{1+\sqrt{17}}{4}$

32 $x \approx -0.586$ 33 $c = 4 + \frac{\pi}{4}$

34 a) $f'(x) = \pi \cos(\pi x)e^{1+\sin \pi x}$ b) $x_n = \frac{2n+1}{2}$

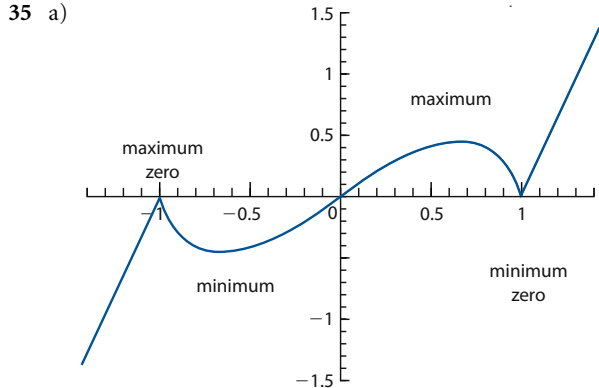

b) (i) $f'(x) = \frac{7x^2 - 3}{3(x^2 - 1)^{\frac{1}{3}}}$, domain: $-1.4 \leq x \leq 1.4$, $x \neq \pm 1$

(ii) Maximum at $x = \sqrt{\frac{3}{7}}$, minimum at $x = -\sqrt{\frac{3}{7}}$

c) $x \approx 1.1339$

36 $a = -4$, $b = 18$

37 a) $\frac{dy}{dx} = \sec^2 x - 8 \cos x$ b) $\cos x = \frac{1}{2}$

38 a) $y = -4x - 8$ b) $(-2, 0)$

39 Proof

40 $y = -x + 2$

41 a) (i) $f'(x) = \frac{2(x^2 - 1)}{(x^2 + x + 1)^2}$

(ii) $A(1, \frac{1}{3})$, $B(-1, 3)$ (or $A(-1, 3)$, $B(1, \frac{1}{3})$)

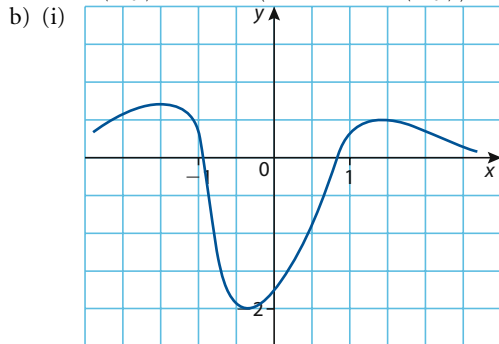

(ii) $x \approx -0.347, 1.153, 1.88$

c) (i) Range of f : $[\frac{1}{3}, 3]$ (ii) range of $f \circ f$: $[\frac{1}{3}, \frac{7}{13}]$

42 $\frac{1}{2\pi}$ cm/s

43 $y = \frac{4}{3}x - \frac{5}{3}$

44 a) (ii) $f''(x) = \frac{x^2(\ln 2)^2 - 4x \ln 2 + 2}{2^x}$

b) (i) $x = \frac{2}{\ln 2}$

(ii) $f''(\frac{2}{\ln 2}) < 0$; therefore, a maximum

c) $x = \frac{2+\sqrt{2}}{\ln 2} \approx 4.93$, $x = \frac{2-\sqrt{2}}{\ln 2} \approx 0.845$

45 a) $f'(t) = 6 \sec^2 t \tan t + 5$ [or $f'(t) = \frac{6 \sin t}{\cos^3 t} + 5$]

b) (i) $3 + 5\pi$ (ii) 5

46 a) $y = -1$ b) $\frac{dy}{dx} = \frac{4}{5}$

47 a) $\frac{dy}{dx} = 3e^{3x} \sin(\pi x) + \pi e^{3x} \cos(\pi x)$ b) $x \approx 0.743$

48 240 km/hr 49 b) $(-\frac{1}{c} \ln b, \frac{a}{2b})$

50 a) $p = 2$ b) $-\frac{4}{7}$

51 $x \approx 0.460$ 52 $\frac{1}{10}$ radians/sec

53 $\frac{d^2y}{dx^2} = \frac{-4}{(2x-1)^2}$ 54 $y = -\frac{5}{4}x + \frac{13}{2}$

55 a) $f''(x) = 10 \cos(5x - \frac{\pi}{2})$

b) $f(x) = -\frac{2}{5} \cos(5x - \frac{\pi}{2}) + \frac{7}{5}$

56 $\frac{5}{4}$ 57 $(-0.803, -2.08)$

58 a) $k = \frac{\ln 2}{20}$ b) 510 bacteria per minute

59 $f(x) = -\frac{1}{5}x^3 + \frac{12}{5}x^2 - 3x + 2$

60 a) $f'(x) = -12 \cos^2(4x+1) \sin(4x+1)$

b) $x = \frac{\pi-2}{8}$, $x = \frac{3\pi-2}{8}$, $x = \frac{\pi-1}{4}$

61 $\frac{dy}{dx} = \frac{3x^2 - (\ln 3)3^{x+y}}{(\ln 3)3^{x+y} - 3}$

62 a) $f'(x) = \frac{3}{3x+1}$ b) $y = -\frac{7}{3}x + \frac{14}{3} + \ln 7$

63 Verify

64 $\frac{dy}{dx} = \frac{1-e}{e}$ 65 b) $b = \sqrt{6}$

66 a) $\frac{dy}{dx} = \frac{2-k}{2k-1}$ b) $k = 2$ 67 $\frac{3}{2}$

68 a) $5\sqrt{5}\sqrt{x^2+4} + 5(2-x)$ minutes

c) (i) $x = 1$ (ii) 30 minutes

(iii) $\frac{d^2T}{dx^2} > 0$ for $x = 1$; therefore, it's a minimum

69 a) $P(-\frac{1}{2}, -\frac{1}{2e})$

b) $f''(x) = 4x + 4 = 0$ at $x = -1$, and $f''(x)$ changes sign at $x = -1$

c) (i) Concave up for $x > -1$

(ii) Concave down for $x < -1$

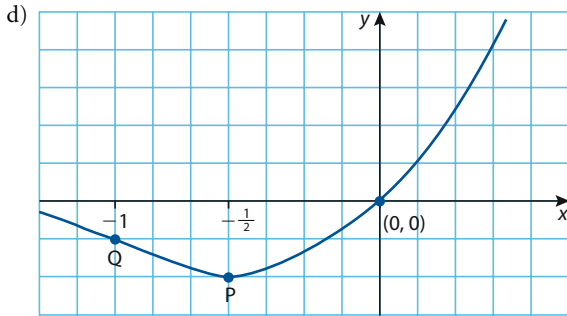

e) Show true for $n = 1$:

$$f'(x) = e^{2x} + 2xe^{2x}$$

$$= e^{2x}(1 + 2x) = (2x + 2^0) e^{2x}$$

Assume true for $n = k$, i.e. $f^{(k)}(x)$

$$= (2^k x + k \times 2^{k-1}) e^{2x}, k \geq 1$$

Consider $n = k + 1$, i.e. an attempt to find $\frac{d}{dx}(f^{(k)}(x))$

$$f^{(k+1)}(x) = 2^k e^{2x} + 2e^{2x}(2^k x + k \times 2^{k-1})$$

$$= (2^k + 2(2^k x + k \times 2^{k-1})) e^{2x}$$

$$= (2 \times 2^k x + 2^k + k \times 2 \times 2^{k-1}) e^{2x}$$

$$= (2^{k+1} x + 2^k + k \times 2^k) e^{2x}$$

$$= (2^{k+1} x + (k+1)2^k) e^{2x}$$

$P(n)$ is true for $k \Rightarrow P(n)$ is true for $k + 1$, and since true for $n = 1$, result proved by mathematical induction $\forall n \in \mathbb{Z}^+$

70 $\frac{72}{\pi} \arccos \frac{8}{13}$ cm

71 a)

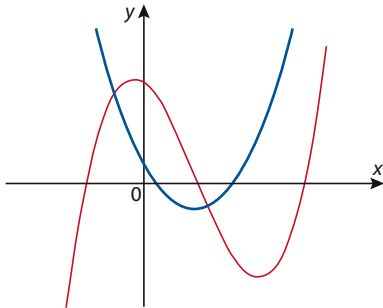

b)

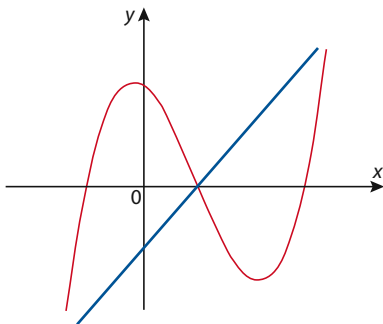

Chapter 16

Exercise 16.1

1 $\frac{x^2}{2} + 2x + c$

3 $\frac{x}{3} - \frac{x^4}{14} + c$

2 $t^3 - t^2 + t + c$

4 $\frac{2t^3}{3} + \frac{t^2}{2} - 3t + c$

5 $\frac{5u^{\frac{7}{2}}}{7} - u^4 + c$

7 $-3 \cos \theta + 4 \sin \theta + c$

9 $\frac{4x^2\sqrt{x}}{5} - \frac{10x\sqrt{x}}{3} + c$

11 $\frac{1}{3}e^{3t-1} + c$

13 $\frac{1}{6} \ln(3t^2 + 5) + c$

15 $\frac{(2x+3)^3}{6} + c$

17 $-\frac{x^5}{5} + \frac{x^4}{4} + \frac{x^2}{2} + 2x - \frac{11}{20}$

19 $3x^4 - 4x^2 + 7x + 3$

21 $\frac{(3x^2+7)^6}{36} + c$

23 $\frac{8\sqrt{(5x^3+2)^5}}{75} + c$

25 $\frac{\sqrt{(2t^3-7)^3}}{9} + c$

27 $-\frac{\cos(7x-3)}{7} + c$

29 $\frac{1}{5} \tan(5\theta-2) + c$

31 $\frac{1}{2} \sec 2t + c$

33 $\frac{1}{3} e^{2t\sqrt{t}} + c$

35 $\ln|\ln 2z| + c$

37 $\frac{1}{3} \tan \theta^3 + c$

39 $\frac{1}{12} \tan^6 2t + c$

41 $\frac{1}{10} \sec^5 2t + c$

43 $-\frac{k^3}{2a^4} \sqrt{a^2 - a^4 x^4} + c = -\frac{k^3}{2|a|^3} \sqrt{1 - a^2 x^4} + c$

44 $\frac{2}{5}(3x^2 - x - 2)\sqrt{x-1} + c$

45 $-\frac{1}{\pi} \cot \pi t + c$

46 $-\frac{2}{3} \sqrt{(1 + \cos \theta)^3} + c$

47 $\frac{2}{105}(15t^3 - 3t^2 - 4t - 8)\sqrt{1-t} + c$

48 $\frac{1}{15}(3r^2 + 2r - 13)\sqrt{2r-1} + c$

49 $\frac{1}{2} \ln(e^{x^2} + e^{-x^2}) + c$

50 $\frac{2}{15}(3t^2 + 20t + 230)\sqrt{t-5} + c$

6 $\frac{4x\sqrt{x}}{3} - 3\sqrt{x} + c$

8 $t^3 + 2 \cos t + c$

10 $3 \sin \theta - 2 \tan \theta + c$

12 $2 \ln|t| + c$

14 $e^{\sin \theta} + c$

16 $-\frac{5x^4}{4} + \frac{2x^3}{3} + cx + k$

18 $\frac{4t^3}{3} + \sin t + ct + k$

20 $2 \sin \theta + \frac{1}{2} \cos 2\theta + c$

22 $-\frac{1}{18(3x^2+5)^3} + c$

24 $\frac{(2\sqrt{x}+3)^6}{6} + c$

26 $-\frac{(2x+3)^6}{18x^6} + c$

28 $-\frac{1}{2} \ln(\cos(2\theta-1)+3) + c$

30 $\frac{1}{\pi} \sin(\pi x + 3) + c$

32 $\frac{1}{2} e^{x^2+1} + c$

34 $\frac{2}{3} (\ln \theta)^3 + c$

36 $-\frac{1}{15} \sqrt{(3-5t^2)^3} + c$

38 $-\cos \sqrt{t} + c$

40 $2 \ln(\sqrt{x}+2) + c$

42 $\frac{1}{2} \ln|x^2+6x+7| + c$

Exercise 16.2

1 $-\frac{1}{3}e^{-x^3} + c$

2 $-e^{-x}(x^2 + 2x + 2) + c$

3 $\frac{2}{9}x \cos 3x - \frac{2}{27} \sin 3x + \frac{1}{3}x^2 \sin 3x + c$

4 $\frac{1}{a^3}(2 \cos ax - a^2 x^2 \cos ax + 2ax \sin ax) + c$

5 $\sin x(\ln(\sin x) - 1) + c$

6 $\frac{1}{2}x^2(\ln x^2 - 1) + c$

7 $\frac{1}{3}x^3 \ln x - \frac{1}{9}x^3 + c$

8 $2e^x + x^2 e^x - 2xe^x - \frac{1}{3}x^3 + c$

9 $\frac{1}{\pi^2}(\cos \pi x + \pi x \sin \pi x) + c$

10 $\frac{3}{13} \cos 2t e^{3t} + \frac{2}{13} e^{3t} \sin 2t + c$

11 $\sqrt{1-x^2} + x \arcsin x + c$ 12 $e^x(x^3 - 3x^2 + 6x - 6) + c$

13 $-\frac{1}{4}e^{-2x}(\cos 2x + \sin 2x) + c$

14 $\frac{1}{2}x(\sin(\ln x) - \cos(\ln x)) + c$

15 $\frac{1}{2}x(\sin(\ln x) + \cos(\ln x)) + c$

16 $\ln|x+1| - 2x + x \ln|x^2+x| + c$

17 $\frac{e^{kx}(k \sin x - \cos x) + c}{k^2 + 1}$

18 $x \tan x + \ln|\cos x|$

19 $\frac{2}{3}\sin^3 x$

20 $\frac{1}{2}\arctan x(1+x^2) - \frac{1}{2}x + c$

21 $2\sqrt{x}(\ln x - 2) + c$

22 $t \tan t + \ln|\cos x| + c$

23 Verification

24 $-x^4 \cos x + 4x^3 \sin x + 12x^2 \cos x - 24x \sin x - 24 \cos x + c$

25 $x^5 \sin x + 5x^4 \cos x - 20x^3 \sin x - 60x^2 \cos x + 120x \sin x + 120 \cos x + c$

26 $e^x(x^4 - 4x^3 + 12x^2 - 24x + 24) + c$

27 Proof

28 Proof

29 Proof

30 Proof

31 Proof

Exercise 16.3

1 $\frac{1}{80}\cos 5t - \frac{1}{48}\cos 3t - \frac{1}{8}\cos t; c \frac{\cos^5 t}{5} - \frac{\cos^3 t}{3} + c$

2 $\frac{\cos^6 t}{6} - \frac{\cos^4 t}{4} + c$

3 $\frac{\cos^4 3\theta}{12} + c$

4 $\frac{1}{3}\cos^3\left(\frac{1}{t}\right) - \frac{2}{5}\cos^5\left(\frac{1}{t}\right) + \frac{1}{7}\cos^7\left(\frac{1}{t}\right) + c$

5 $\sec x + \cos x + c$ 6 $\frac{1}{18}\tan^6 3x + c$

7 $\frac{1}{24}(3 \tan^4 \theta^2 + 2 \tan^6 \theta^2) + c$

8 $\frac{2}{5}\sec^5 \sqrt{t} - \frac{2}{3}\sec^3 \sqrt{t} + c$

9 $\frac{1}{15}(\tan^3 5t - 3 \tan 5t + 15t) + c$

10 $\tan t - \sec t + c$

11 $\csc t - \cot t + c$

12 $-\ln|1 - \sin t| + c$

13 $-2x - 3 \ln|\sin x + \cos x| + c$

14 $\arctan(\sec \theta) + c$

15 $\frac{1}{2}(\arctan t)^2 + c$

16 $\ln|\arctan t| + c$

17 $\arcsin(\ln x) + c$

18 $\frac{-\cos x}{3}(\sin^2 x + 2) + c$ 19 $\frac{2}{5}(\cos^2 x \sqrt{\cos x} - 5\sqrt{\cos x}) + c$

20 $\frac{-\cos \sqrt{x}}{3}(2 \sin^2 \sqrt{x} + 4) + c$

21 $\frac{\sin(\sin t)}{3}(\cos^2(\sin t) + 2) + c$

22 $\ln|\sin \theta| + 2 \sin \theta + c$

23 $t \sec t - \ln|\sec t + \tan t| + c$

24 $-\ln(2 - \sin x) + c$

25 $\frac{1}{2}\ln|\cos(e^{-2x})| + c$

26 $2 \ln|\sec \sqrt{x} + \tan \sqrt{x}| + c$

27 $\frac{1}{2}\tan x + c$

28 $\frac{1}{6}(\arcsin 3x + 3x\sqrt{1-9x^2}) + c$

29 $\frac{x}{4\sqrt{x^2+4}} + c$

30 $2 \ln|t + \sqrt{t^2+4}| + \frac{1}{2}t\sqrt{t^2+4} + c$

31 $\frac{3}{2}\arctan\left(\frac{1}{2}e^t\right) + c$

32 $\frac{1}{2}\arcsin\left(\frac{2}{3}x\right) + c$

33 $\frac{1}{3}\ln\left|\frac{3}{2}x + \frac{1}{2}\sqrt{9x^2+4}\right| + c$

34 $\ln|\sqrt{1+\sin 2x} + \sin x| + c$

35 $-\sqrt{4-x^2} + c$

36 $\frac{1}{2}\ln(x^2+16) + c$

37 $-\arcsin\left(\frac{x}{2}\right) - \frac{\sqrt{4-x^2}}{x} + c$

38 $\frac{1}{9\sqrt{9-x^2}} + c$

39 $\frac{(x^2+1)^{\frac{3}{2}}}{3} + c$

40 $\frac{(e^{2x}+1)^{\frac{3}{2}}}{3} + c$

41 $\frac{1}{2}(\arcsin(e^x) + e^{\sqrt{1-e^{2x}}}) + c$

42 $\ln\left(\frac{1}{3}e^x + \frac{1}{3}\sqrt{e^{2x}+9}\right) + c$

43 $2\sqrt{x}(\ln x - 2) + c$

44 $12 \ln(x+2) + \frac{8}{x+2} + \frac{x^2}{2} - 4x + c$

45 $\frac{1}{2}\ln(x^2+9) + c_1$; $x = 3 \tan \theta$ yields $\ln\left(\frac{\sqrt{x^2+9}}{3}\right) + c_2$; they differ by a constant

46 $x - 3 \arctan\left(\frac{x}{3}\right) + c_1$; $x = 3 \tan \theta$ yields

$3(\tan \theta - \theta) + c_2 = 3\left(\frac{x}{3} - \arctan \frac{x}{3}\right) + c_2$

Exercise 16.4

1 24

2 40

3 $\frac{24}{25}$

4 0

5 $\frac{176\sqrt{7}-44}{5}$

6 0

7 2

8 -268

9 $\frac{64}{3}$

10 2

11 $\ln\left(\frac{11}{3}\right)$

12 $\frac{44}{3} - 8\sqrt{3}$

13 3

14 $\sqrt{\pi} + 1$

15 a) 6 b) 6 c) 12

16 1

17 4

18 0

19 $\frac{\pi}{2}$

20 $\frac{\pi}{6}$

21 $\frac{\pi}{3}$

22 $\frac{\pi}{8}$

23 $\frac{14\sqrt{17}+2}{3}$

24 $\frac{1}{\pi}$

25 $\ln(2)$

26 $16\sqrt{2} - 5\sqrt{5}$

27 $\sqrt{14} - \sqrt{10}$

28 $\frac{3}{2}$

29 $\pi^{\frac{3}{2}}\left(\frac{2\sqrt{3}}{27} - \frac{1}{12}\right)$

30 $\frac{\pi}{6}$

31 $-\frac{1}{2}\ln\left(\frac{37}{52}\right)$

32 $-\arctan\left(\frac{\sqrt{15}-\sqrt{7}}{4}\right)$ or $\frac{1}{2}\left(\arcsin\left(\frac{1}{4}\right) - \arcsin\left(\frac{3}{4}\right)\right)$

33 $\frac{2}{3}$

34 0

35 -4

36 $\frac{\pi}{6}$

37 $\frac{1}{6}\arctan\left(\frac{4\sqrt{3}}{9}\right)$

38 $\frac{\pi\sqrt{3} - 3\sqrt{3}\arctan\left(\frac{\sqrt{3}}{2}\right)}{18}$

39 $\frac{1}{6}$

40 $\frac{e-1}{2}$

41 $1 + \frac{e}{2}$

42 $2 \cos(1) + 2$

43 $\frac{31}{5}$

44 $\frac{2}{\pi}$

45 $\frac{12-4\sqrt{3}}{\pi}$

46 $\frac{e^8-1}{8e^8}$

47 $\frac{\pi}{6 \ln 3}$

48 $\frac{\sin x}{x}$

- 49 $-\frac{\sin t}{t}$
 51 $2x \frac{\sin x^2}{x^2}$
 53 $\frac{b-a}{5+x^4}$
 55 $\frac{1}{4x^4} \left(e^{x+3x^2} \right)$
 57 a) $\frac{1}{3} \ln \left(\frac{3k+2}{2} \right)$
 58 Proof
 60 a) 0
 c) $\frac{15\sqrt{47}}{47}$
 61 Proof

- 50 $-2x \frac{\sin x^2}{x^2}$
 52 $\frac{\cos t}{1+t^2}$
 54 $-\csc \theta - \sec \theta$
 56 Yes
 b) $k = \frac{2(e^3 - 1)}{3}$
 59 $-(1-x)^{k+1} \left(\frac{1}{k+1} + \frac{1-x}{k+2} \right)$
 b) $\sqrt{47}$

Exercise 16.5

- 1 $\frac{1}{2}((1+2\sqrt{2})\ln x - \sqrt{2}|1 + (1-2\sqrt{2})\ln x + \sqrt{2}|)$
 2 $3\ln|x-2| - 2\ln|x| + c$
 3 $\frac{1}{2}\ln|x^2 + 4x + 3| + c$
 4 $-\ln|x+1| + 6\ln|x| - \frac{9}{x+1} + c$
 5 $\ln|x+3| + 3\ln|x+2| - 2\ln|x| + c$
 6 $\ln|x+1| + 3\ln|x| + \frac{1}{x} + c$
 7 $-\ln|x+2| + \ln|x-1| + c$
 8 $\frac{3\ln|2x-1|}{2} - 2\ln|x+1| + c$
 9 $3\ln|x+2| + \frac{2}{x+2} + c$
 10 $\ln|x-2| - 4\ln|x+1| + 3\ln|x| + \frac{6}{x} + c$
 11 $-\ln|x^2+1| + 2\ln|x| + c$
 12 $\frac{\sqrt{3}}{3} \arctan \left(\frac{\sqrt{3}x}{3} \right) - \frac{\ln|x^2+3|}{3} + \frac{2\ln|x|}{3} + c$
 13 $\frac{\sqrt{3}}{2} \arctan \left(\frac{x}{\sqrt{6}} \right) - \frac{\ln|x^2+6|}{6} + \frac{\ln|x|}{3} + c$
 14 $\frac{\sqrt{2}}{2} \arctan \left(\frac{\sqrt{2}x}{4} \right) - \frac{3}{16} \ln|x^2+8| + \frac{3}{8} \ln|x| + c$
 15 $\frac{\ln|x-5|}{3} + \frac{2\ln|x+1|}{3} - \ln|x| + c$

Exercise 16.6

- 1 $\frac{125}{6}$
 3 $4\sqrt{3}$
 5 $\frac{8}{21}$
 7 $\frac{13}{12}$
 9 $\frac{59}{12}$
 11 $3\ln 2 - \frac{63}{128}$
 13 18
 16 9
 19 $\frac{2\sqrt{3}}{3} + 2$
 22 $\frac{2\sqrt{2}}{3}$
 25 $\frac{288\sqrt{3}}{35}$
 2 $\frac{9\pi^2}{8} + 1$
 4 $\frac{10}{3}$
 6 $\frac{125}{24}$
 8 4π
 10 Approx. 361.95 (4 points of intersection!)
 12 Between $-\frac{\pi}{6}$ and $\frac{\pi}{6}$, $\sqrt{3} \ln \left(\frac{3}{4} \right) - 2\sqrt{3} + 4$
 14 $\frac{32}{3}$
 17 $\frac{9}{2}$
 20 $\frac{37}{12}$
 23 $\frac{269}{54}$
 26 $\frac{2\sqrt{2}}{3}$
 15 $\frac{64}{3}$
 18 19
 21 $\frac{1}{2}$
 24 $\frac{e}{2} - 1$
 27 $\frac{16}{3}$

28 25.36

29 $m = 0.973$

30 $\frac{37}{12}$

Exercise 16.7

- 1 $\frac{127\pi}{27}$
 3 $\frac{70\pi}{3}$
 5 9π
 7 $\left(\frac{\sqrt{3}}{2} + 1 \right) \pi$
 9 Approx. 5.937 π
 11 $\pi(\sqrt{3}-1)$
 13 $288\pi - \frac{160\pi\sqrt{5}}{3}$
 15 $\pi \left(\frac{1}{2} - \frac{1}{4}\sqrt{3} \right)$
 17 $\frac{252}{5}\pi$
 19 $\frac{9}{8}\pi$
 21 40π
 23 $\frac{32}{15}\pi$
 25 $2\pi \left(\ln 2 - \frac{1}{4} \right)$
 27 $\frac{28}{3}\pi(\sqrt{34}-\sqrt{7})$
 29 $\frac{284}{3}\pi$
 31 $\frac{256}{15}\pi$
 2 $\frac{64\sqrt{2}\pi}{15}$
 4 6π
 6 2π
 8 $\frac{512\pi}{15}$
 10 $\frac{32\pi}{3}$
 12 $\frac{23\pi}{210}$
 14 $\frac{64}{15}\pi$
 16 $\frac{1778}{5}\pi$
 18 1419 π
 20 a) $\frac{88}{15}\pi$ b) $\frac{7}{6}\pi$
 22 $9\pi(2-\sqrt{2})$
 24 $\frac{4}{5}\pi(121\sqrt{33}-25\sqrt{15})$
 26 $2\pi \left(\frac{11}{3}\sqrt{11} - \frac{2}{3}\sqrt{2} \right)$
 28 $\pi \left(\frac{1}{2}\sqrt{2}\pi - \pi + 2 \right)$
 30 2π

Exercise 16.8

- 1 $\frac{70}{3}$ m, 65 m
 3 1 m, 1 m
 5 18 m, 28.67 m
 7 3t, 6 m, 6 m
 9 $1 - \cos t, \left(\frac{3\pi}{2} + 1 \right) \text{m}, \left(\frac{3\pi}{2} + 1 \right) \text{m}$
 10 $4 - 2\sqrt{t+1}, 2.43 \text{ m}, 2.91 \text{ m}$
 11 $3t^2 + \frac{1}{2(1+t)^2} + \frac{3}{2}, 11.3 \text{ m}, 11.3 \text{ m}$
 12 $4.9t^2 + 5t + 10$
 14 $\frac{1}{\pi} - \frac{\cos \pi t}{\pi}$
 16 $e^t + 19t + 4$
 18 $\sin(2t) - 3$
 20 12; 20
 22 $\frac{9}{4}, \frac{11}{4}$
 24 $-\frac{10}{3}, \frac{17}{3}$
 26 $-6, \frac{13}{2}$
 28 a) $50 - 20t$
 29 1.27 s
 30 a) 5 s
 d) -49 m/s
 2 8.5 m to the left, 8.5 m
 4 2 m, $2\sqrt{2}$ m
 6 $\frac{4}{\pi} \text{ m}, \frac{4}{\pi} \text{ m}$
 8 $t^2 - 4t + 3, 0, 2.67 \text{ m}$
 13 $16t^2 - 2t + 1$
 15 $\ln(t+2) + \frac{1}{2}$
 17 $4.9t^2 - 3t$
 19 $-\cos \left(\frac{3t}{\pi} \right)$
 21 $\frac{13}{2}, \frac{13}{2}$
 23 $2\sqrt{3} - 6; 6 - 2\sqrt{3}$
 25 $\frac{204}{25}$
 27 $\frac{166}{5}; \frac{166}{5}; \frac{166}{5}$
 b) 1062.5
 c) 10 s
 f) -73.08 m/s

Exercise 16.9

- 1 $y = \pm 10e^{x^2}$
- 2 $y = \pm e^{\frac{1}{2}x^2}$
- 3 $y = \frac{2}{2-x^2}$
- 4 $y = \frac{1}{3-x}$
- 5 $y = \ln\left(\frac{e}{1-ex}\right)$
- 6 $y = \ln(e^x - C)$
- 7 $y^3 = \frac{3(x+1)^2}{2} - \frac{1}{2}$
- 8 $y = \frac{1}{\ln|x+1|+1}$
- 9 $2y^3 + 6y = 3x^2 + 6x + 72$
- 10 $y^2 = e^{x^2} - 1$
- 11 $\arctan y = \frac{x^2}{2} + c$
- 12 $y + \ln|y| = \frac{x^2}{2} - x + 1$
- 13 $x + \ln\frac{1}{x + Ce^x + 1}$
- 14 $\frac{y-1}{y+1} = e^{(x-1)^2} + c$
- 15 $(y+1)\ln|y+1| + 1 = (y+1)(\ln|\ln x|) + c$
- 16 $1 + 2y^2 = c \tan^4 \frac{x}{2}$
- 17 $\arcsin y = 1 - \sqrt{1-x^2}$
- 18 $y = \ln\left(\ln\frac{e^{(e^x+1)}}{1+e}\right)$
- 19 $y + |\ln y| = \frac{x^3}{3} - x - 5$
- 20 $\cos y = \frac{\sqrt{2}}{4}(e^x + 1)$
- 21 $|y| = |x|e^{x^2-1}$
- 22 $2\ln|y| - y^2 = e^{x^2} - 2$
- 23 $y + \ln|\sec y| = \frac{1}{3}x^3 + x + c$
- 24 $\sqrt{(y^2+1)^3} = 3e^t(t-1) + c$
- 25 $e^{-y}(y+1) = -\frac{1}{3}\sin^3 \theta + c$
- 26 $e^{3y} + 3y^2 = 3(\cos x + x \sin x) - 2$
- 27 $y = e^x - x^2 + 2$
- 28 b) $C = 78; m = \frac{1}{15} \ln \frac{8}{13}; 45.3$ minutes

Practice questions

- 1 a) $p = 3$ b) 3 square units
- 2 a) (0, 1) b) $V = \int_0^{\ln 2} (e^{\frac{x}{2}})^2 dx$
- 3 $a = e^2$
- 4 a) $y = \frac{x}{e}$
- 5 a) (i) 400 m (ii) $v = 100 - 8t, 60$ m/s
(iii) 8 s (iv) 1344 m
b) Distance needed 625
- 6 b) 2.31 c) $-\pi \cos x - \frac{x^2}{2} + c, 0.944$
- 7 $\ln 3$
- 8 a) (ii) (1.57, 0); (1.1, 0.55); (0, 0), (2, -1.66)
b) $x = \frac{\pi}{2}$ c) (ii) $\int_0^{\frac{\pi}{2}} x^2 \cos x dx$ d) $\frac{\pi^2}{2} - 2$
- 9 a) 2π
b) Range: $\{y | -0.4 < y < 0.4\}$
c) (i) $-3 \sin^3 x + 2 \sin x$ (iii) $\frac{2\sqrt{3}}{9}$
d) $\frac{\pi}{2}$
e) (i) $\frac{1}{3} \sin^3 x + c$ (ii) $\frac{1}{3}$
f) $\arccos \frac{\sqrt{7}}{3} \approx 0.491$
- 10 c) 3.696 72 d) $\int_0^{\pi} (\pi + x \cos x) dx$
e) $\pi^2 - 2 \approx 7.869 60$
- 11 a) (i) $10x + 1 - e^{2x}$ (ii) $\frac{\ln 5}{2} \approx 0.805$
b) (i) $f^{-1}(x) = \frac{\ln(x-1)}{2}$

- c) $v = \pi \int_0^{\ln 2} (1 + e^{2x})^2 dx$
- 12 $\pi\left(\frac{2}{15}a^5 + \frac{2}{3}a^3\right)$
- 13 $4\left(\frac{2}{5}\left(\frac{1}{2}x+1\right)^{\frac{5}{2}} - \frac{2}{3}\left(\frac{1}{2}x+1\right)^{\frac{3}{2}}\right) + c$
- 14 $a = -\frac{56}{27}$ 15 $\frac{\pi}{2}(e^{2k} - 1)$
- 16 $k = 2$ 17 1800 m
- 18 $2a$ by $\frac{2}{3}a^2$
- 19 a) $\ln x + 1 - k$ b) $x > \frac{1}{e}$
c) (ii) $(e^k, 0)$ d) $\frac{e^{2k}}{4}$
e) $y = x - e^k$ f) Verify
g) Common ratio = e
- 20 $x^2 - 4y^2 = 4$ 21 $v = \sqrt{v_0^2 + \frac{4k}{m}}$

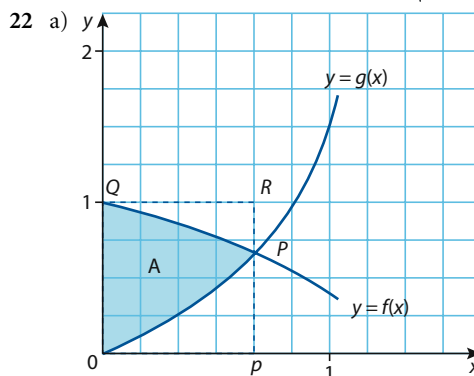

- 22 a) y axis
- b) Proof c) 0.6937
- d) $\int_0^p (e^{-x^2} - (e^{-x^2} - 1)) dx \approx 0.467$
- 23 a) Verify
b) $\frac{2\pi}{9}, \frac{4\pi}{9}, \frac{6\pi}{9}$
c) $\frac{n\pi}{9}(n+1)$
- 24 a) $t = 0, 3, \text{ or } 6$
b) (i) $\int_0^6 t \sin\left(\frac{\pi}{3}t\right) dt$ (ii) 11.5 m
- 25 a) 0.435 b) $\frac{-2t}{(2+t^2)^2}$
- 26 a) $\frac{dy}{dx} = \frac{2x^2}{\sqrt{1+x^2}} + 2\sqrt{1+x^2}$
b) Verify c) $k = 0.918$
- 27 6 m
- 28 0.852
- 29 a) Verify
a) (i) $A = 78; k = \frac{1}{15} \ln \frac{48}{78}$ (ii) 45.3
- 30 $y = \tan\left(\ln \frac{x}{2}\right)$
- 31 $\frac{(x+2)^2}{2} - 6(x+2) + 12 \ln|x+2| + \frac{8}{x+2} + c$

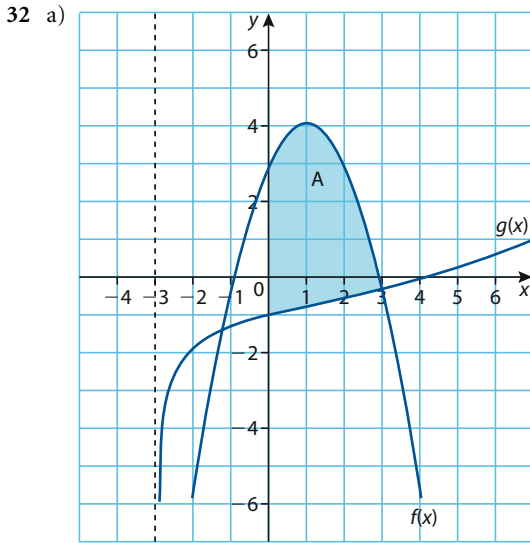

- b) (i) $x = -3$;
(ii) $x - \text{int} = e^2 - 3$; $y - \text{int} = \ln 3 - 2$
c) -1.34 ; 3.05
d) (ii) $\int_0^{3.05} (4 - (1-x)^2 - (\ln(x+3) - 2)) dx$
(iii) 10.6
e) 4.63

- 33 a) Verify
b) $\ln x - \frac{1}{2} \ln(x^2 + 1) + c$
c) $y = \frac{2e^\theta}{\sqrt{e^{2\theta} + 1}}$

Chapter 17

Exercise 17.1

- 1 a) Discrete b) Continuous c) Continuous
d) Discrete e) Continuous f) Continuous
g) Discrete h) Continuous i) Continuous
j) Discrete k) Continuous l) Continuous
m) Discrete

- 2 a) 0.4

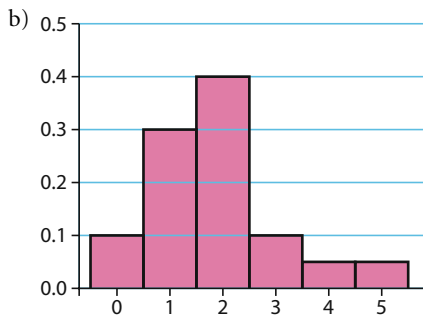

- c) $1.85, 1.19$ e) $2.85, 1.19$
f) $E(X + b) = E(X) + b$; $V(X + b) = V(X)$

- 3 a) 0.26 b) 0.37 c) 0.77
d) 16.29 e) 8.126 f) 4.125 ; 2.01325
g) $E(aX + b) = aE(X) + b$; $V(aX + b) = a^2V(X)$

- 4 a) 0.969 b) 0.163 c) 3.5

- 5 $k = \frac{1}{30}$

x	12	14	16	18
$P(X = x)$	$6k$	$7k$	$8k$	$9k$

- 6 a) $k = \frac{1}{10}$ b) $\frac{37}{60}$ c) $\frac{19}{30}$
d) $E(X) = 16$, $SD = 7$ e) $E(Y) = \frac{11}{5}$; $SD = \frac{7}{5}$

- 7 a) $\frac{1}{50}$

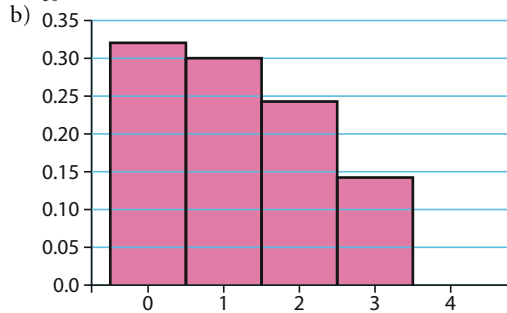

- c) $\frac{17}{25}$
d) $\mu = 1.2$; $\text{var} = 0.9$

- 8 a) $P(x = 18) = 0.2$, $P(x = 19) = 0.1$, symmetric distribution.
b) $\mu = 17$, $SD = 1.095$

- 9 a) $\mu = 1.9$, $SD = 1.34$
b) Between 0 and 5

- 10 $k = 0.667$, $E(X) = 5.44$

- 11 a) $k = 0.3$ or 0.7

- b) for $k = 0.3$: $E(X) = 2.18$; for $k = 0.7$: $E(X) = 1.78$

- 12 a)

y	0	1	2	3
$P(Y = y)$	$\frac{1}{27}$	$\frac{2}{9}$	$\frac{4}{9}$	$\frac{8}{27}$

- b) 2

- 13 a) $k = \frac{1}{10}$ b) $\frac{1}{2}$

- 14 a) <See table below>

- b) 0.85 c) 0.15 d) 48.87

- e) 2.057 f) 0.77

x	45	46	47	48	49	50	51	52	53	54	55
CDF	0.05	0.13	0.25	0.4	0.65	0.85	0.9	0.94	0.97	0.99	1

- 15 a)

x	0	1	2	3	4	5	6
CDF	0.08	0.23	0.45	0.72	0.92	0.97	1

- b) 0.72 c) 0.97

- d) 2.63 e) 1.44

- 16 a) 0.90 b) 0.09 c) 0.009

- d) Unacceptable, acceptable e) $p(x) = (0.1^{x-1}) \times 0.90$

- 17 a) 0 b) 0.81 c) 0.162

- d) Either acceptable or unacceptable, acceptable

- e) $(x - 1)(0.1^{x-2}) \times 0.90^2$, $x > 1$

- 18 $n = 30$

- 19 a) (i) $\frac{1}{9}$ (ii) $\frac{1}{81}$

- b) (i) $\frac{73}{648}$ (ii) $\frac{575}{1296}$