



Mathematics PreDP1 Exercise Book

Tomasz Lechowski

2 SLO

Copyright © Tomasz Lechowski Warszawa 2024.

Revisions and corrections provided by:

Answers provided and checked by:

Contents

1	Operations on Numbers	5
1.1	Types of numbers	5
1.2	Fractions and decimals	21
1.3	Percentages	30
1.4	Financial Mathematics and Exponential Growth	39
1.5	Ratio and proportion	50
1.6	Approximation and rounding	62
1.7	Laws of Indices	70
1.8	Standard form	80
1.9	Surds	87
1.10	Speed, distance and time	95
1.11	Money and finance	106
1.12	Set notation and Venn diagrams	113
1.13	End of unit test	130

Chapter 1

Operations on Numbers

1.1 Types of numbers

We use the following notation to denote various types of numbers:

\mathbb{N} **natural numbers**: $0, 1, 2, 3, 4, \dots$. Note that some textbooks do not include 0 as a natural number. We include 0 in the set of natural numbers.

\mathbb{Z} **integers**: $\dots, -3, -2, -1, 0, 1, 2, 3, \dots$. Note that every natural number is an integer. The natural numbers are the non-negative integers.

\mathbb{Q} **rational numbers** are the numbers that can be expressed as a fractions of two integers (with non-zero denominator). Note that every integers is a rational number. For example -3 can be expressed as a fraction of two integers as $\frac{-6}{2}$. Equivalently we can define rational numbers as numbers that have finite or recurring decimal expansion, so 0.42 and $0.33333\dots$ are both rational numbers (the first one is $\frac{21}{50}$, the second is $\frac{1}{3}$).

\mathbb{R} **real numbers** include all rational numbers but also **irrational numbers**, so numbers that lie on the number line, but cannot be expressed as fractions of integers. Real numbers include numbers like $\sqrt{2}$ and π .

Note that every natural number is an integer, but not every integer is a natural number. Every integer is a rational number, but not every rational number is an integer. And every rational number is real, but not every real number is rational. This relationship between these sets of numbers can be represented by the following diagram:

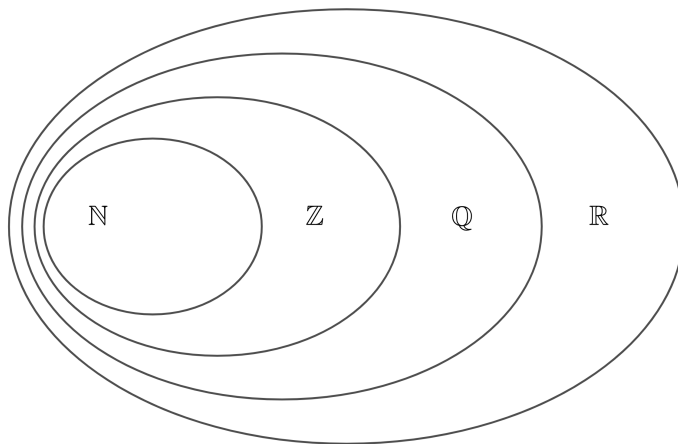

Worked example 1.1.1

Classify the following numbers by placing them in appropriate regions of the above diagram.

$$0, \quad \frac{10}{-5}, \quad (-2)^3$$

$$5\frac{1}{3}, \quad \sqrt{3}, \quad \sqrt{4}$$

0 is a natural number,

$\frac{10}{-5} = -2$ so it is an integer, but not a natural number,

$(-2)^3 = -8$ so it is an integer, but not a natural number,

$5\frac{1}{3} = \frac{16}{3}$ it is a rational number, but not an integer,

$\sqrt{3}$ is real number and it is irrational,

$\sqrt{4} = 2$ so it is a natural number.

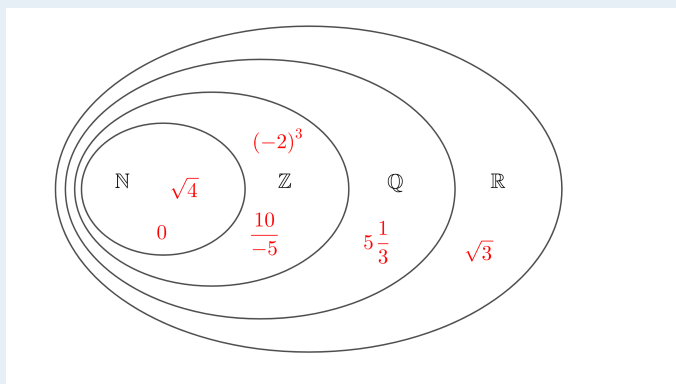

Exercise 1.1.1. Place the following numbers in appropriate regions of the diagram below:

$$0.1111\dots, \quad \frac{8}{2}, \quad (\sqrt{2})^2, \quad (\sqrt{2})^3, \quad \sqrt{5}, \quad 2\pi, \quad \frac{\sqrt{2}}{2}, \quad (-1)^{100}, \quad (-1)^{101}, \quad \frac{-5}{\frac{1}{2}}$$

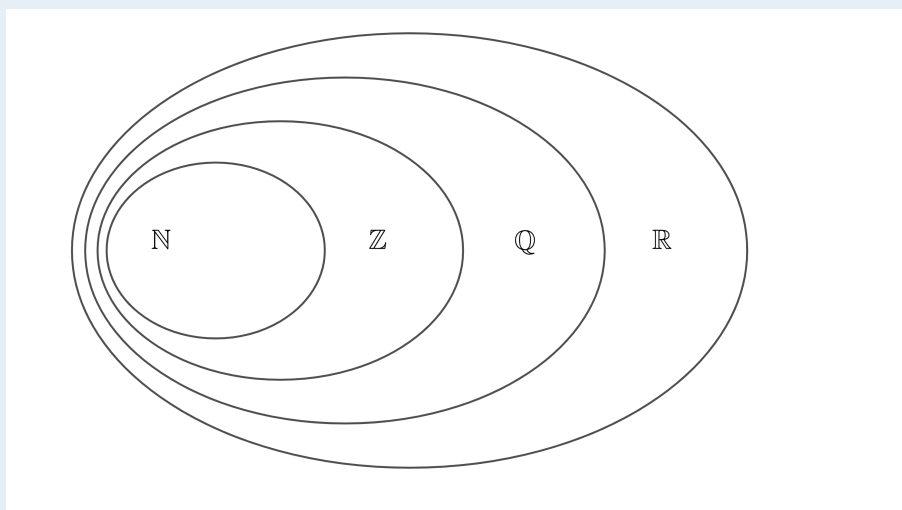

There are other types of numbers that you should be familiar with

Prime numbers are natural numbers greater than 1 that are not products of two smaller natural numbers. Note that 1 is **not** a prime number by definition. 12 is also not a prime number as it can be written as $12 = 3 \times 4$ and both 3 and 4 are smaller than 12. 5 is a prime number, it can be written as 1×5 , but 5 is not smaller than 5. It can also be written as 2×2.5 , but 2.5 is not a natural number. Here is a list of all prime numbers smaller than 100:

2, 3, 5, 7, 11, 13, 17, 19, 23, 29, 31, 37, 41, 43, 47, 53, 59, 61, 67, 71, 73, 79, 83, 89, 97

Composite numbers - natural numbers greater than 1 which aren't prime are called composite numbers. Note that 1 is neither prime nor composite.

Triangular numbers:

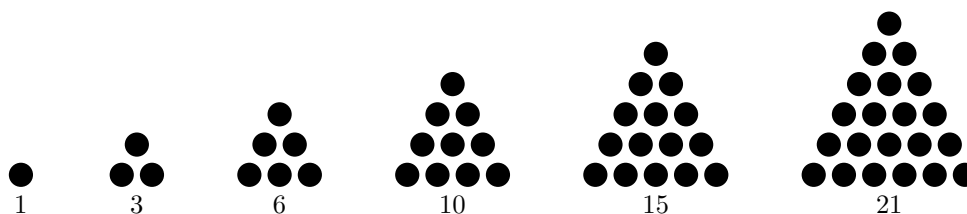

The n -th triangular number is given by the formula $\frac{n(n+1)}{2}$.

Square numbers:

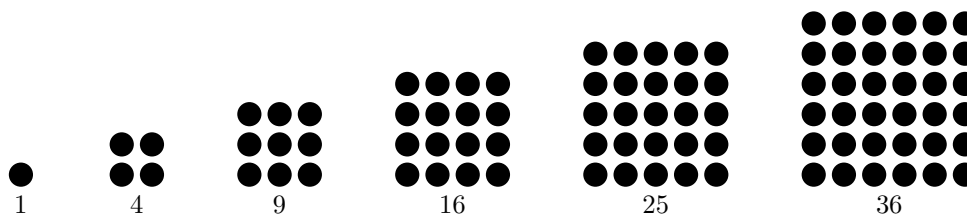

The n -th square number is given by the formula n^2 .

Cube numbers:

$$1^3 = 1, \quad 2^3 = 8, \quad 3^3 = 27, \quad 4^3 = 64, \quad 5^3 = 125, \quad 6^3 = 216, \quad 7^3 = 343, \dots$$

The n -th cube number is given by the formula n^3 .

Exercise 1.1.2. Write down the 10-th:

- (a) prime number (b) triangular number (c) square number (d) cube number

Note that there is no known formula for the n -th prime number.

FACTORS

A **factor** of a natural number n is a natural number that divides n exactly (without remainder). The number 20 has 6 factors:

1, 2, 4, 5, 10, 20

Note that every natural number greater than 1 has at least 2 factors: 1 and itself. Another (equivalent to the one above) definition of a prime number is that it is a natural number which has **exactly** two factors.

Exercise 1.1.3. List all the factors of:

(a) 25

(b) 40

(c) 60

(d) 200

DIVISIBILITY RULES

When a number a is a factor of a number b , then we say that b is divisible by a and write $a|b$. A number is divisible by:

2 if its last digit is 0, 2, 4, 6 or 8.

3 if the sum of its digits is divisible by 3.

4 if the number made up of its last two digits is divisible by 4.

5 if its last digit is 0 or 5.

6 if its divisible by both 2 and 3.

8 if the number made up of its last three digits is divisible by 8.

9 if the sum of its digits is divisible by 3.

10 if its last digit is 0.

11 if the sum of every other digit minus the remaining digits is divisible by 11.

Worked example 1.1.4

Decide if 542 124 is divisible by 2, 3, 4, 5, 6, 8, 9, 10 or 11.

The last digit is 4, so it is divisible by 2.

The sum of the digits is $5 + 4 + 2 + 1 + 2 + 4 = 18$, which is divisible by 3 and also by 9, so the number is divisible by 3 and 9. Since it is divisible by 2 and 3, it is also divisible by 6.

The last two digits make a number 24, which is divisible by 4, so the number itself is divisible by 4.

The last digit is not 0 nor 5, so the number is not divisible by 5 or 10.

The last two digits make a number 124, which is not divisible by 8, so the number is not divisible by 8.

The sum of every other digit minus the remaining digits is $5 + 2 + 2 - 4 - 1 - 4 = 0$, which is divisible by 11, so the number is divisible by 11.

542 124 is divisible by 2, 3, 4, 6, 9 and 11.

Exercise 1.1.4. Decide if the following numbers are divisible by 2, 3, 4, 5, 6, 8, 9, 10 or 11.

(a) 12056

(b) 591375

(c) 292820

(d) 658489

PRIME FACTORIZATION

A factor which is a prime number is called a **prime factor**. 20 has 6 factors, 2 of which are prime factors: 2 and 5.

Exercise 1.1.5 List all the prime factors of:

(a) 75

(b) 80

(c) 100

(d) 200

A factor of a number, which isn't the number itself is called a **proper factor**. The proper factors of 20 are: 1, 2, 4, 5, 10. The sum of proper factors of a number may be smaller than the number itself (proper factors of 10 are: 1, 2 and 5; and $1 + 2 + 5 < 10$), it can also be greater than the number (proper factors of 20: $1 + 2 + 4 + 5 + 10 > 20$). A number whose sum of proper factors is equal to the number itself is called a **perfect number**. The first four perfect numbers are: 6, 28, 496 and 8128.

The **Fundamental Theorem of Arithmetic** states that every natural number greater than 1 can be uniquely written as a product of prime numbers. For example:

$$3960 = 2 \times 2 \times 2 \times 3 \times 3 \times 5 \times 11 = 2^3 \times 3^2 \times 5 \times 11$$

The theorem says that 3960 can be written as a product of prime numbers (as it was shown above), but also that this is the only way it can be done - there will always be three 2, two 3, one 5 and one 11.

Worked example 1.1.6

Write 7020 as a product of prime factors.

7020 is divisible by 2, we have $7020 = 2 \times 3510$.

3510 is also divisible by 2, so we get $7020 = 2 \times 2 \times 1755$.

1755 is no longer divisible by 2, but it is divisible by 3, so $7020 = 2 \times 2 \times 3 \times 585$.

We continue this way to get:

$$7020 = 2 \times 2 \times 3 \times 3 \times 3 \times 5 \times 13 = 2^2 \times 3^3 \times 5 \times 13$$

The whole process can be quickly done using the following notation:

7020	2
3510	2
1755	3
585	3
195	3
65	5
13	13
1	

So

$$7020 = 2 \times 2 \times 3 \times 3 \times 3 \times 5 \times 13 = 2^2 \times 3^3 \times 5 \times 13$$

Exercise 1.1.6 Write the following numbers as products of primes.

(a) 72

(b) 250

(c) 392

(d) 1400

(e) 3663

(f) 21125

(g) 22032

(h) 35937

Consider a number written as a product of primes:

$$n = p_1^{a_1} \times p_2^{a_2} \times p_3^{a_3} \times \dots \times p_m^{a_m}$$

Any factor of n must be of the form:

$$f = p_1^{b_1} \times p_2^{b_2} \times p_3^{b_3} \times \dots \times p_m^{b_m}$$

where $0 \leq b_i \leq a_i$. Which means that the number of factors of n is

$$\text{number of factors of } n = (a_1 + 1) \times (a_2 + 1) \times (a_3 + 1) \times \dots \times (a_m + 1)$$

Consider the number 20, written as a product of primes $20 = 2^2 \times 5^1$. The number of factors of 20 will be $(2 + 1) \times (1 + 1) = 6$, but let's look closer into it. Any factor of 20 must be written in the form $2^x \times 5^y$ where x can be 0, 1 or 2 and y can be 0 or 1. There are 3 possible values of x and for each of those we have 2 possible values of y , so there are $3 \times 2 = 6$ possible factors of 20. These are:

$$2^0 \times 5^0 = 1, \quad 2^1 \times 5^0 = 2, \quad 2^2 \times 5^0 = 4, \quad 2^0 \times 5^1 = 5, \quad 2^1 \times 5^1 = 10 \quad \text{and} \quad 2^2 \times 5^1 = 20$$

Exercise 1.1.7 Find the number of factors of:

(a) 36

(b) 84

(c) 120

(d) 1080

COMMON FACTORS

The following are all the factors of 220 and of 320:

220 : 1, 2, 4, 5, 10, 11, 20, 22, 44, 55, 110 and 220;

320 : 1, 2, 4, 5, 8, 10, 16, 20, 32, 40, 64, 80, 160 and 320;

The numbers that are factors of both 220 and 320 are called **common factors** of these numbers. They are:

1, 2, 4, 5, 10 and 20

Of these 20 is the highest and it is called the **highest common factor**. We can write this information as:

$$\text{hcf}(220, 320) = 20$$

Some authors use the term **greatest common divisor** and the notation $\text{gcd}(220, 320) = 20$ instead.

Worked example 1.1.8

Find the highest common factor of 120 and 450.

Method 1 We can list all the factors of 120 and of 450:

120 : 1, 2, 3, 4, 5, 6, 8, 10, 12, 15, 20, 24, 30, 40, 60 and 120;

450 : 1, 2, 3, 5, 6, 9, 10, 15, 18, 25, 30, 45, 50, 75, 90, 150, 225, and 450;

The common factors are:

1, 2, 3, 5, 6, 10, 15 and 30

The highest common factor is then 30, i.e. $\text{hcf}(120, 450) = 30$.

Method 2 We factorize both numbers into prime factors:

120	2	450	2
60	2	225	3
30	2	75	3
15	3	25	5
5	5	5	5
1		1	

Now we can see that 2, 3 and 5 each appear in the prime factorization of both numbers (each once), so the highest common factor is $\text{hcf}(120, 450) = 2 \times 3 \times 5 = 30$.

Note that if we want to find the highest common factor of more than two numbers, then we can use the fact that $\text{hcf}(a, b, c) = \text{hcf}(\text{hcf}(a, b), c)$. However it is often easier to simply look for the prime factors that appear in the prime factorization of each of the numbers.

Exercise 1.1.8 Find the highest common factor of the following numbers:

- | | | |
|--------------------|--------------------|---------------------------|
| (a) 72 and 100 | (b) 140 and 343 | (c) 1020 and 1422 |
| (d) 2400 and 3006 | (e) 2592 and 3888 | (f) 3993 and 5120 |
| (g) 42, 60 and 108 | (h) 60, 85 and 500 | (i) 90, 120, 144 and 1000 |

If $\text{hcf}(a, b) = 1$, then we say that a and b are **co-prime**.

Exercise 1.1.9 List all pairs of co-prime numbers from the following list:

21, 30, 55, 60, 100, 121, 125, 128, 200

MULTIPLES

The following are the first few multiples of 6, 8 and 10:

6 : 6, 12, 18, 24, 30, 36, 42, 48, 54, 60, 66, ...

8 : 8, 16, 24, 32, 40, 48, 56, 64, 72, 80, 88, ...

10 : 10, 20, 30, 40, 50, 60, 70, 80, 90, 100, ...

The common multiples of 6 and 8 are: 24, 48, 72, The **least common multiple** is 24. We can write this as:

$$\text{lcm}(6, 8) = 24$$

Similarly we have $\text{lcm}(6, 10) = 30$, $\text{lcm}(8, 10) = 40$ and finally $\text{lcm}(6, 8, 10) = 120$.

Worked example 1.1.10

Find the least common multiple of 30 and 36.

Method 1

We start listing the multiples of 30 and 36 until we find one that is on both lists:

30 : 30, 60, 90, 120, 150, 180, ...;

36 : 36, 72, 108, 144, 180, ...;

So we have $\text{lcm}(30, 36) = 180$.

Method 2

We factorize both numbers into prime factors:

30	2	36	2
15	3	18	2
5	5	9	3
1		3	3
		1	

Numbers 2 and 3 appear once in both factorizations - they're marked in red. Take all the remaining numbers and multiply. We get $5 \times 2 \times 2 \times 3 \times 3$ or just 5×36 which gives 180.

Exercise 1.1.10 Find the least common multiple of the following numbers:

(a) 12 and 15

(b) 14 and 20

(c) 22 and 33

(d) 24 and 30

(e) 36 and 60

(f) 37 and 40

(g) 8, 12 and 15

(h) 10, 12 and 18

(i) 18, 24, 30 and 40

Any multiple of 2 (i.e. an even number) can be written as $2k$, where $k \in \mathbb{N}$. Similarly any multiple of 3 can be written as $3k$, where $k \in \mathbb{N}$. A natural number which is not a multiple of 2 (i.e. an odd number) can be written as $2k + 1$ for $k \in \mathbb{N}$.

Exercise 1.1.11 Write down a general form of a number which:

(a) is a multiple of 4

(b) is a multiple of 10

(c) leaves remainder of 1 when divided by 3

(d) leaves remainder of 3 when divided by 4

(e) leaves remainder of 5 when divided by 7

(f) leaves remainder of 1 when divided by 10

Worked example 1.1.12

Prove that for any natural number n the numbers n and n^2 have the same parity (either both are even or both are odd).

Suppose n is even, then $n = 2k$ for some natural number k , then

$$n^2 = (2k)^2 = 4k^2 = 2 \times 2k^2 = 2m$$

where m is a natural number, so n^2 is even.

Now suppose n is odd, then $n = 2k + 1$ for some natural number k , then

$$\begin{aligned} n^2 &= (2k + 1)^2 = (2k + 1)(2k + 1) = 4k^2 + 2k + 2k + 1 = \\ &= 2 \times (2k^2 + 2k) + 1 = 2m + 1 \end{aligned}$$

where m is a natural number, so n^2 is odd.

So if n is even, then so is n^2 and if n is odd, then so is n^2 , which means that n and n^2 have the same parity. □

Exercise 1.1.12a Prove that a sum of two odd numbers is even.

Exercise 1.1.12b Prove that a sum of three consecutive numbers is divisible by 3.

Exercise 1.1.12c Show that a square number can never have a remainder of 2, when divided by 3.

Exercise 1.1.12d* Prove that none of:

$$2, \quad 22, \quad 222, \quad 2222, \quad 22222, \dots$$

is a square number.

ROOTS

\sqrt{y} (square root of y) denotes a positive number x such that $x^2 = y$. For example $\sqrt{4} = 2$ and $\sqrt{1.44} = 1.2$. It is important to understand that there are two numbers that when squared equal to 4, these are of course 2 and -2 , but $\sqrt{4} = 2$, $\sqrt{4} \neq -2$. In fact we can write that the two solutions to the equation $x^2 = 4$ are $\sqrt{4}$ and $-\sqrt{4}$. Note also that there is no real number that when squared gives a negative number, which means that numbers like $\sqrt{-3}$ or $\sqrt{-100}$ are not real numbers. Note that $\sqrt{0} = 0$, as $0^2 = 0$.

$\sqrt[3]{y}$ (cube root of y) denotes a number x such that $x^3 = y$. For example $\sqrt[3]{8} = 2$. Note that cube roots of negative numbers are real e.g. $\sqrt[3]{-27} = -3$ as $(-3)^3 = -27$.

In general we have $\sqrt[m]{y}$ denotes a number x such that $x^m = y$, but in the case when m is even, we additionally require x to be positive. For example $\sqrt[4]{81} = 3$ and $\sqrt[5]{1024} = 4$.

Exercise 1.1.13 Calculate:

(a) $\sqrt{2.56}$

(b) $\sqrt{\frac{4}{625}}$

(c) $\sqrt{2\frac{1}{4}}$

(d) $\sqrt{16.81}$

(e) $\sqrt{\frac{25}{1024}}$

(f) $\sqrt{5\frac{4}{9}}$

(g) $\sqrt[3]{0.001}$

(h) $\sqrt[3]{\frac{8}{27}}$

(i) $\sqrt[3]{4\frac{17}{27}}$

(j) $\sqrt[3]{0.064}$

(k) $\sqrt[3]{\frac{216}{343}}$

(l) $\sqrt[3]{2\frac{93}{125}}$

(m) $\sqrt[4]{0.0081}$

(n) $\sqrt[4]{\frac{1}{625}}$

(o) $\sqrt[4]{1\frac{3439}{6561}}$

(p) $\sqrt[5]{0.00032}$

(q) $\sqrt[5]{\frac{1}{243}}$

(r) $\sqrt[5]{7\frac{19}{32}}$

RECIPROCAL

A **reciprocal** of a non-zero number a is the number $\frac{1}{a}$. A **negation** of a number a is the number $-a$.

Worked example 1.1.14

Find the negative reciprocals of:

(a) $4\frac{1}{2}$,

(b) $-\frac{1}{15}$.

(a) We have:

$$-\frac{1}{4\frac{1}{2}} = -\frac{1}{\frac{9}{2}} = -\frac{2}{9}$$

(b) We have:

$$-\frac{1}{-\frac{1}{15}} = -(-15) = 15$$

Exercise 1.1.14a Find the reciprocals of

(a) -5

(b) $\frac{2}{11}$

(c) $5\frac{1}{3}$

(d) 3.2

(e) $-\frac{1}{10000}$

(f) $10\frac{1}{10}$

Exercise 1.1.14b Find the negative reciprocals of

(a) -2

(b) $\frac{1}{7}$

(c) $2\frac{2}{3}$

(d) 1.5

(e) $-\frac{3}{4}$

(f) $1\frac{8}{9}$

Irrationality of $\sqrt{2}$

1. Write the following numbers as products of prime factors:

$$6^2, \quad 10^2, \quad 18^2, \quad 24^2$$

What do you notice about the number of times each prime appears in the prime factorization of a square number?

2. Explain why the 2 must appear even number of times in a prime factorization of a square number.
3. How many times will 2 appear in a prime factorization of $2k^2$, where k is an integer?
4. What would it mean, if $\sqrt{2}$ were rational?
5. Show that if $\sqrt{2} = \frac{p}{q}$ for non-zero integers p and q , then it must be the case that: $2q^2 = p^2$
6. Comment on the number of times 2 appears in the prime factorization of $2q^2$ and p^2 .
7. State the conclusion of your investigation.
8. Repeat the above argument for $\sqrt{3}$.
9. Why does the above argument not work for $\sqrt{4}$?

The following examples show how to use you GDC for calculations required in this section.

EXAMPLE 1

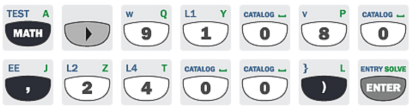
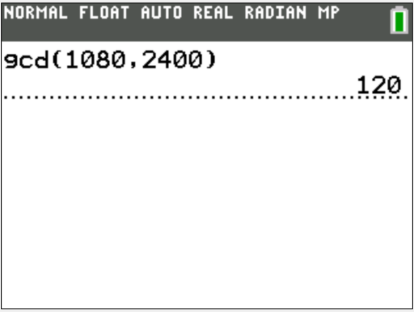
<p>Calculate:</p> <p>$hcf(1080, 2400)$</p>	<p>INPUT</p> 	<p>OUTPUT</p> 
--	---	---

Note that on Ti-84 the command *gcd* (greatest common divisor) is used instead of *hcf* (highest common factor).

EXAMPLE 2

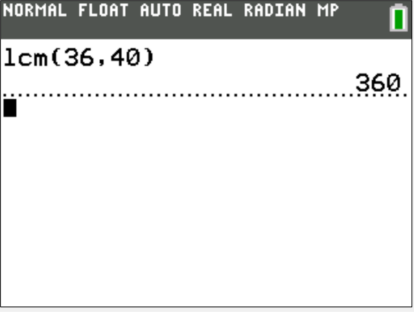
<p>Calculate:</p> <p>$lcm(36, 40)$</p>	<p>INPUT</p> 	<p>OUTPUT</p> 
--	---	---

EXAMPLE 3

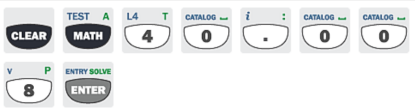
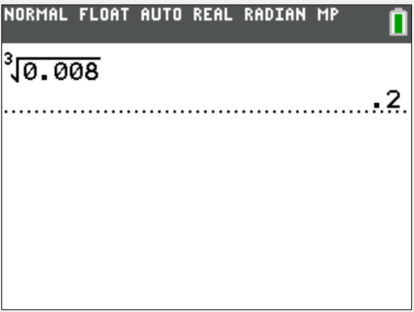
<p>Calculate:</p> <p>$\sqrt[3]{0.008}$</p>	<p>INPUT</p> 	<p>OUTPUT</p> 
--	---	---

EXAMPLE 4

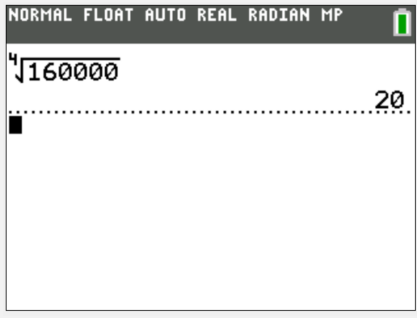
<p>Calculate:</p> $\sqrt[4]{160000}$	<p>INPUT</p> 	<p>OUTPUT</p> 
--------------------------------------	--	--

EXAMPLE 5

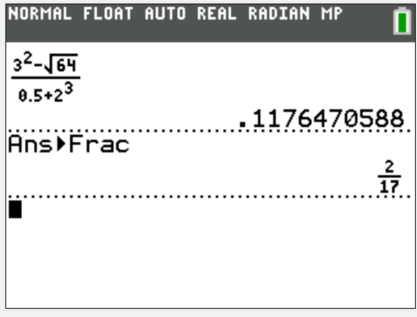
<p>Calculate:</p> $\frac{3^2 - \sqrt{64}}{0.5 + 2^3}$	<p>INPUT</p> 	<p>OUTPUT</p> 
---	---	---

Note that on never versions of Ti-84 you can press ALPHA + LINK to make a fraction.

EXAMPLE 6

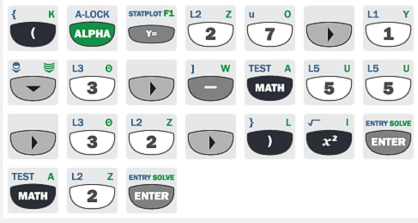
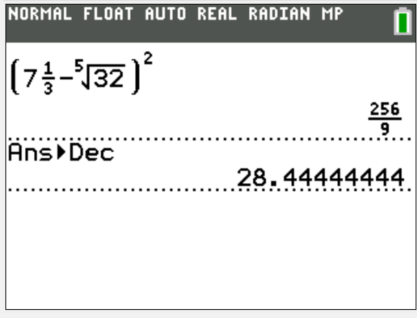
<p>Calculate:</p> $\left(7\frac{1}{3} - \sqrt[5]{32}\right)^2$	<p>INPUT</p> 	<p>OUTPUT</p> 
--	--	--

SHORT TEST

1. [4 points]

Consider the following numbers:

$$a = \text{reciprocal of } -\frac{1}{6}, \quad b = \frac{333333333333222}{3}, \quad c = \sqrt[3]{-\frac{1}{27}}, \quad d = \sqrt{\text{hcf}(18, 27)}$$

Place each number in an appropriate part of the diagram below:

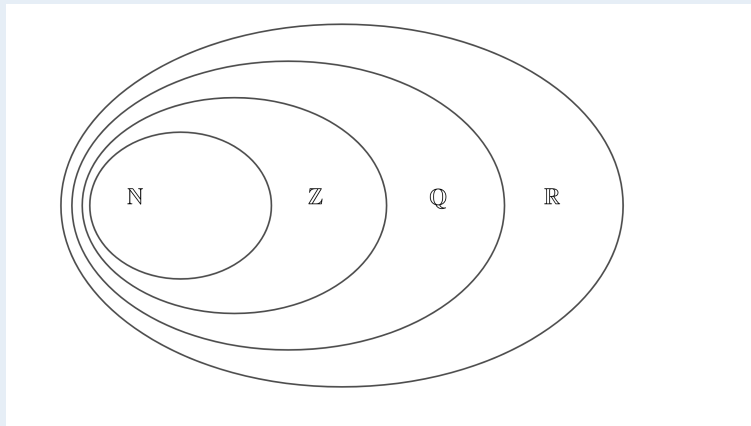

2. [4 points]

Calculate:

(a) $\text{hcf}(48, 72, 120)$

(b) $\text{lcm}(18, 24, 50)$

(c) $\sqrt{1\frac{9}{16}}$

(d) $\sqrt[3]{0.008}$

3. [2 points]

Write down 180 as a product of primes and hence state the number of factors of 180.

4. [2 points]

Write down a general form of a natural number that:

(a) is divisible by 2 and 3

(b) leaves remainder of 2 when divided by 4

**SHORT TEST
SOLUTIONS**

1. [4 points]
Consider the following numbers:

$$a = \text{reciprocal of } -\frac{1}{6}, \quad b = \frac{333333333333222}{3}, \quad c = \sqrt[3]{-\frac{1}{27}}, \quad d = \sqrt{\text{hcf}(18, 27)}$$

Place each number in an appropriate part of the diagram below:

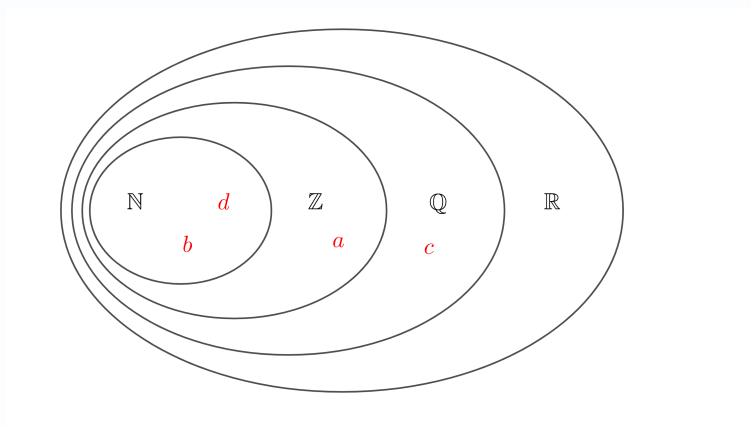

2. [4 points]
Calculate:

(a) $\text{hcf}(48, 72, 120) = 24$

(b) $\text{lcm}(18, 24, 50) = 1800$

(c) $\sqrt{1\frac{9}{16}} = \sqrt{\frac{25}{16}} = \frac{5}{4} = 1\frac{1}{4}$

(d) $\sqrt[3]{0.008} = 0.2$

3. [2 points]
Write down 180 as a product of primes and hence state the number of factors of 180.

$$180 = 2^2 \times 3^2 \times 5$$

$$\text{number of factors} = (2 + 1) \times (2 + 1) \times (1 + 1) = 18$$

4. [2 points]
Write down a general form of a natural number that:

(a) is divisible by 2 and 3

(b) leaves remainder of 2 when divided by 4

(a) $6k, \quad k \in \mathbb{N}$

(b) $4k + 2, \quad k \in \mathbb{N}$

1.2 Fractions and decimals

A fraction of two natural numbers $\frac{a}{b}$, where $b \neq 0$ is called a **proper fraction** if $a < b$. If $a > b$ it is an **improper fraction**. Fractions are **simplified** if a and b are co-prime (that is $\text{hcf}(a, b) = 1$). In order to simplify a fraction we can divide the numerator and the denominator by $\text{hcf}(a, b)$. A **mixed number** is a natural number and a proper fraction.

Exercise 1.2.1 Simplify the following fractions. If the fraction is improper, write your answer as a mixed number.

(a) $\frac{80}{36}$

(b) $\frac{18}{120}$

(c) $\frac{81}{54}$

(d) $\frac{60}{24}$

(e) $\frac{99}{135}$

(f) $\frac{70}{28}$

(g) $\frac{1000}{144}$

(h) $\frac{48}{92}$

(i) $\frac{121}{726}$

A decimal representation of a number is a way of writing the number using powers of 10 only (including negative powers, so numbers like $\frac{1}{10}$, $\frac{1}{100}$, $\frac{1}{1000}$ etc.). For example 24.153 represents 2 tens, 4 units, 1 tenth, 5 hundredths and 3 thousandths i.e. $20 + 4 + \frac{1}{10} + \frac{5}{100} + \frac{3}{1000}$.

Exercise 1.2.2a Write the following fractions as decimals.

(a) $\frac{3}{40}$

(b) $\frac{5}{8}$

(c) $\frac{13}{20}$

(d) $\frac{19}{5}$

(e) $\frac{11}{80}$

(f) $\frac{65}{16}$

Exercise 1.2.2b Write the following decimals as simplified fractions. If the fraction is improper, write your answer as a mixed number.

(a) 0.4

(b) 0.012

(c) 0.005

(d) 3.04

(e) 10.02

(f) 5.55

A decimal representation may have recurring digits. For example a decimal representation of $\frac{1}{3}$ is 0.33333... where the digit 3 repeats forever. This can be written as $0.\dot{3}$. If more than one digits repeats itself then we use the following notation:

$$5.1212121212\dots = 5.\dot{1}2 \quad 10.0103103103\dots = 10.0\dot{1}0\dot{3} \quad 2.11912339123391233\dots = 2.11\dot{9}12\dot{3}3$$

Note that we place the dot above the first and the last of the set of recurring digits.

Worked example 1.2.3a

Write $0.\dot{1}2\dot{6}$ as a proper fraction in simplified form.

Denote our number by x , so that:

$$x = 0.126126126\dots$$

Now we have:

$$1000x = 126.126126126\dots$$

Note that we consider $1000x$ because 3 digits (1,2 and 6) recur. If we had 2 digits recurring, we would consider $100x$ instead.

Now subtract the first equation from the second one to get:

$$999x = 126$$

Which gives $x = \frac{126}{999} = \frac{14}{111}$

Worked example 1.2.3b

Write $\frac{13}{27}$ as a decimal.

We need to perform long division:

$$\begin{array}{r} 0.48\dot{1} \\ 27 \overline{)13.000} \\ \underline{10.8} \\ 2.20 \\ \underline{2.16} \\ 40 \\ \underline{27} \\ 13 \end{array}$$

At this point we get back to 13 and the process repeats, so the digits 481 will be the recurring digits.

Exercise 1.2.3c Write the following as proper fractions in simplified form.

(a) $0.\dot{2}$

(b) $0.\dot{1}\dot{2}$

(c) $0.\dot{1}2\dot{3}$

(d) $0.\dot{3}6\dot{3}$

(e) $0.\dot{2}34\dot{9}$

(f) $0.\dot{1}312\dot{2}$

(g) $0.\dot{1}28\dot{5}$

(h) $0.0\dot{1}1\dot{4}$

(i) $0.03\dot{5}212\dot{5}$

Exercise 1.2.3b Write the following as mixed number in simplified form.

(a) $1.\dot{5}$

(b) $1.3\dot{5}$

(c) $10.\dot{1}0\dot{1}$

(d) $5.\dot{5}1\dot{1}$

(e) $100.\dot{1}00\dot{1}$

(f) $99.\dot{9}999\dot{0}$

Exercise 1.2.3a Write the following as decimals.

(a) $\frac{1}{15}$

(b) $\frac{5}{9}$

(c) $\frac{7}{6}$

(d) $\frac{5}{27}$

(e) $\frac{25}{54}$

(f) $\frac{1}{7}$

Note that any rational number will have a finite or recurring decimal expansion. The fraction $\frac{1}{49}$ has a recurring decimal expansion and the length of the list of repeating digits is 42. This means that on the GDC, if we type $1 \div 49$ we wouldn't know that it has a recurring decimal expansion (as the number of displayed digits is fewer than 42).

Worked example 1.2.4

Calculate:

$$\frac{\frac{2}{5} + \frac{3}{4}}{1.2 - \frac{7}{8}} \div \frac{2}{3}$$

Write your answer as a mixed number.

We have $1.2 = \frac{12}{10} = \frac{6}{5}$. We make a common denominator for fractions appearing in the numerator and denominator of the first term:

$$\frac{\frac{8}{20} + \frac{15}{20}}{\frac{48}{40} - \frac{35}{40}} \div \frac{2}{3} =$$

Now we add/subtract the fractions:

$$= \frac{\frac{23}{20}}{\frac{13}{40}} \div \frac{2}{3} =$$

Dividing by a fraction is equivalent to multiplying by its reciprocal, this gives:

$$= \frac{23}{20} \times \frac{40}{13} \times \frac{3}{2} =$$

We simplify first and then multiply:

$$= \frac{23}{1} \times \frac{1}{13} \times \frac{3}{1} = \frac{69}{13} = 5\frac{4}{13}$$

When we have sums or differences of fractions in the numerator and the denominator it is often a good idea to multiply both by the least common multiple of the denominators of these fractions, so when we have:

$$\frac{\frac{2}{5} + \frac{3}{4}}{\frac{6}{5} - \frac{7}{8}} \div \frac{2}{3} =$$

it is quicker to proceed by multiplying the numerator and the denominator by 40 (least common multiple of 5, 4 and 8). This gives:

$$= \frac{16 + 30}{48 - 35} \div \frac{2}{3} = \frac{46}{13} \times \frac{3}{2} = \frac{69}{13} = 5\frac{4}{13}$$

Exercise 1.2.4 Calculate the following. Give your answer as a proper fraction or a mixed number.

$$(a) \frac{\frac{2}{3} + \frac{1}{6}}{1.6 - \frac{1}{4}} \div \frac{3}{7}$$

$$(b) \frac{\frac{5}{6} + \frac{9}{10}}{0.95 - \frac{4}{5}} \div \frac{7}{8}$$

$$(c) \frac{\frac{3}{5} + 0.7}{\frac{9}{10} - \frac{3}{4}} \times \frac{5}{6}$$

$$(d) \frac{\frac{3}{7} + 0.6}{\frac{5}{8} - \frac{1}{2}} \times 0.9$$

$$(e) 0.25 + \frac{\frac{3}{5} - 0.3}{\frac{5}{8} + \frac{1}{4}} \times \frac{4}{5}$$

$$(f) 0.4 + \frac{\frac{5}{8} - 0.3}{\frac{1}{3} + \frac{2}{7}} \div 1.2$$

$$(g) \frac{1}{3} + \frac{\frac{3}{5} - 0.2}{\frac{4}{7} + \frac{1}{3}} \times 0.6$$

$$(h) \frac{1}{4} + \frac{0.285714 - 0.15}{\frac{1}{2} + \frac{2}{3}} \times 0.8$$

$$(i) \frac{5}{12} + \frac{\frac{1}{3} - 0.1}{\frac{3}{5} + 0.16} \div 2.5$$

$$(j) \frac{1}{4} - \frac{\frac{1}{3} - 0.1}{1 + \frac{1}{3}} \times 0.25$$

$$(k) \frac{3}{4} + \frac{1}{4} \times \frac{\frac{3}{4} - 0.1}{1 + \frac{1}{12}}$$

$$(l) 2\frac{1}{4} - \frac{1}{4} \times \frac{2 - \frac{2}{3}}{\frac{2}{3}}$$

Continued fractions

A given mixed number consists of an integer part and fractional part. For example 3.54 has 3 as integer part and $0.54 = \frac{54}{100} = \frac{27}{50}$ as fractional part.

1. Write down the integer and fractional part of 7.35.

2. Write down the integer and fractional part of the reciprocal of your answer to previous part.

3. Repeat step 2. until there is no fractional part.

You should get that $7.35 = 7 + \frac{1}{2 + \frac{1}{1 + \frac{1}{6}}}$. Note that the numbers 7, 2, 1, and 6 are the integer parts you found in part 2. $7 + \frac{1}{2 + \frac{1}{1 + \frac{1}{6}}}$ is called a **continued fraction**.

In general a continued fraction has the form

$$i_0 + \frac{1}{i_1 + \frac{1}{i_2 + \frac{1}{i_3 + \dots}}}$$

where i_s are the corresponding integer parts in the iterative process described above.

4. Find a continued fraction for the following numbers: 5.21, $\frac{12}{67}$ and 1.234.

5. With the help of GDC to find the first 5 terms of the continued fraction for $\sqrt{2}$.

6. With the help of GDC to find the first 5 terms of the continued fraction for π .

7. What do you notice about your answers to parts 4., 5. and 6.?

The following examples show how to use you GDC for calculations required in this section.

EXAMPLE 1

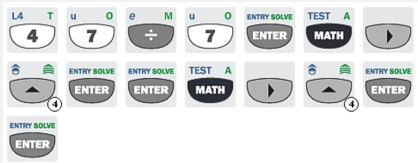
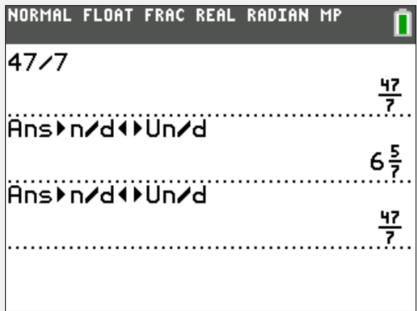
<p>Change a given fraction into a mixed number and <i>vice versa</i>:</p> $\frac{47}{7} = 6\frac{5}{7}$	<p>INPUT</p> 	<p style="text-align: center;">OUTPUT</p> 
---	---	---

EXAMPLE 2

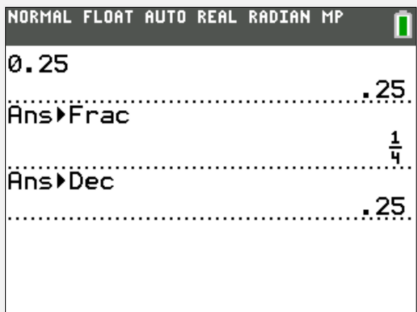
<p>Change between a decimal and a proper fraction</p> $0.25 = \frac{1}{4}$	<p>INPUT</p> 	<p style="text-align: center;">OUTPUT</p> 
--	---	---

EXAMPLE 3

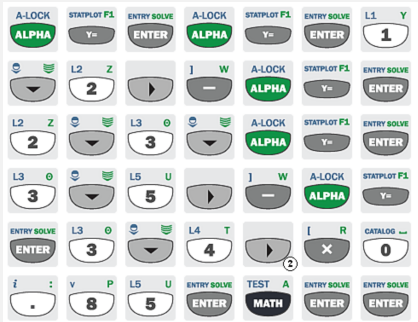
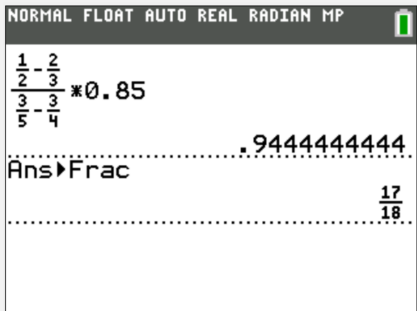
<p>Calculate:</p> $\frac{\frac{1}{2} - \frac{2}{3}}{\frac{3}{5} - \frac{3}{4}} \times 0.85$	<p>INPUT</p> 	<p style="text-align: center;">OUTPUT</p> 
---	---	---

EXAMPLE 4

	INPUT	OUTPUT
<p>Find the integer part and the fractional part of:</p> <p>7.12 and $\sqrt{3}$</p>		

SHORT TEST

1. [3 points]

Write the following as proper fractions or mixed numbers in simplified form:

(a) 0.042

(b) 12.125

(c) $5.\dot{4}\dot{2}$

2. [3 points]

Write the following as decimals:

(a) $\frac{7}{40}$

(b) $\frac{51}{9}$

(c) $\frac{2}{27}$

3. [4 points]

Calculate the following. Give your answer in simplified form as a proper fraction or a mixed number.

(a) $\frac{0.\dot{7} + \frac{2}{3} - \frac{3}{4}}{0.2 - \frac{1}{3}}$

(b) $\frac{1}{3} + \frac{0.\dot{1}\dot{2} - \frac{1}{5}}{\frac{3}{4} - \frac{3}{5}} \times 0.6$

**SHORT TEST
SOLUTIONS**

1. Write the following as proper fractions or mixed numbers in simplified form: [3 points]

(a) 0.042

(b) 12.125

(c) $5.\dot{4}\dot{2}$

(a) $\frac{21}{500}$

(b) $12\frac{1}{8}$

(c) $5\frac{14}{33}$

2. Write the following as decimals: [3 points]

(a) $\frac{7}{40}$

(b) $\frac{51}{9}$

(c) $\frac{2}{27}$

(a) 0.175

(b) $5.\dot{6}$

(c) $0.\dot{0}\dot{7}\dot{4}$

3. Calculate the following. Give your answer in simplified form as a proper fraction or a mixed number. [4 points]

$$(a) \frac{0.\dot{7} + \frac{2}{3}}{0.2 - \frac{1}{3}} - \frac{3}{4} = \frac{\frac{7}{9} + \frac{2}{3}}{\frac{1}{5} - \frac{1}{3}} - \frac{3}{4} = \frac{35 + 30}{9 - 15} - \frac{3}{4} = -\frac{65}{6} - \frac{3}{4} = -\frac{130}{12} - \frac{9}{12} = -\frac{139}{12} = -11\frac{7}{12}$$

$$(b) \frac{1}{3} + \frac{0.\dot{1}\dot{2} - \frac{1}{5}}{\frac{3}{4} - \frac{3}{5}} \times 0.6 = \frac{1}{3} + \frac{\frac{4}{33} - \frac{1}{5}}{\frac{3}{4} - \frac{3}{5}} \times \frac{3}{5} = \frac{1}{3} + \frac{\frac{4}{11} - \frac{3}{5}}{\frac{15}{4} - 3} = \frac{1}{3} + \frac{80 - 132}{825 - 660} = \frac{1}{3} - \frac{52}{165} = \frac{55}{165} - \frac{52}{165} = \frac{3}{165}$$

1.3 Percentages

In order to express quantity a as a percentage of quantity b we calculate the ratio $\frac{a}{b}$ and multiply this ratio by 100%. As an example consider the numbers 80 and 200. We have:

$$\frac{80}{200} \times 100\% = 40\%$$

So 80 is 40% of 200. On the other hand we have:

$$\frac{200}{80} \times 100\% = 250\%$$

Which means that 200 is 250% of 80.

Worked example 1.3.1

Calculate what percent of number b is number a for the following values of a and b :

(a) $a = 30, b = 120$

(a) We have:

$$\frac{30}{120} \times 100\% = 25\%$$

So 30 is 25% of 120.

(b) $a = 300, b = 20$

(b) We have:

$$\frac{300}{20} \times 100\% = 1500\%$$

So 300 is 1500% of 20.

(c) $a = 0.03, b = 15$

(c) We have:

$$\frac{0.03}{15} \times 100\% = 0.2\%$$

So 0.03 is 0.2% of 15.

Exercise 1.3.1

Calculate what percent of number b is number a for the following values of a and b .

(a) $a = 14, b = 25$

(b) $a = 80, b = 16$

(c) $a = 0.02, b = 0.5$

(d) $a = 230, b = 225$

(e) $a = 0.05, b = 12$

(f) $a = 32, b = 0.04$

Exercise 1.3.2

Calculate:

(a) 20% of 90

(b) 0.5% of 82

(c) 24% of 0.5

(d) 13% of 13

(e) 120% of 700

(f) 3000% of 120

When calculating a percentage of a certain number it is worth remembering that multiplication is commutative (that is $a \times b = b \times a$). That is 8% of 25 is the same as 25% of 8. The later is of course much easier to calculate (the answer is 2).

Exercise 1.3.3

Use commutativity of multiplication to calculate without the use of calculator:

- (a) 16% of 50 (b) 40% of 75 (c) 4% of 150
 (d) 0.4% of 25 (e) 620% of 50 (f) 3% of 250

Increasing number by $p\%$ is equivalent to multiplying that number by $(1 + \frac{p}{100})$. Similarly decreasing a number by $p\%$ is equivalent to multiplying that number by $(1 - \frac{p}{100})$. So for example increasing by 40% is the same as multiplying by 1.4, while decreasing by 40% is equivalent to multiplying by 0.6.

Worked example 1.3.4

A number a has been increased(\uparrow)/decreased(\downarrow) by $p\%$. The resulting number is b . Calculate the missing number for the following cases:

(a) $a = 140$, \uparrow , $p = 20$, $b = ?$

(b) $a = 260$, \downarrow , $p = 4$, $b = ?$,

(c) $a = 0.7$, \uparrow , $p = 250$, $b = ?$,

(d) $a = ?$, \downarrow , $p = 10$, $b = 126$,

(e) $a = ?$, \uparrow , $p = 24$, $b = 372$,

(f) $a = 220$, \downarrow , $p = ?$, $b = 209$,

(g) $a = 0.2$, \uparrow , $p = ?$, $b = 0.44$,

(a) Increasing a number by 20% corresponds to multiplication by $1 + \frac{20}{100} = 1.2$, so we have

$$140 \times 1.2 = 168$$

So $b = 168$.

(b) Decreasing a number by 4% corresponds to multiplication by $1 - \frac{4}{100} = 0.96$, so we have

$$260 \times 0.96 = 249.6$$

So $b = 249.6$.

(c) We have $0.7 \times 3.5 = 2.45$. So $b = 2.45$.

(d) We solve $a \times 0.9 = 126$. So $a = \frac{126}{0.9} = 140$.

(e) We solve $a \times 1.24 = 372$. This gives $a = \frac{372}{1.24} = 300$.

(f) We solve $220 \times (1 - \frac{p}{100}) = 209$. This gives $(1 - \frac{p}{100}) = \frac{209}{220}$. So $(1 - \frac{p}{100}) = 0.95$, which gives $p = 5$.

(g) We solve $0.2 \times (1 + \frac{p}{100}) = 0.44$. This gives $(1 + \frac{p}{100}) = \frac{0.44}{0.2}$. So $(1 + \frac{p}{100}) = 2.2$, which gives $p = 120$.

Exercise 1.3.4

A number a has been increased(\uparrow)/decreased(\downarrow) by $p\%$. The resulting number is b . Calculate the missing number for the following cases:

(a) $a = 24, \uparrow, p = 30, b = ?$,

(b) $a = 0.06, \downarrow, p = 8, b = ?$,

(c) $a = ?, \uparrow, p = 15, b = 92$,

(d) $a = ?, \downarrow, p = 12, b = 2288$,

(e) $a = 350, \uparrow, p = ?, b = 490$,

(f) $a = 1.2, \uparrow, p = ?, b = 0.84$.

When a percentage change occurs more than once, then we multiply the given number as many times. If a number 2500 is increased by 20% three times, then the resulting number is:

$$2500 \times 1.2 \times 1.2 \times 1.2 = 2500 \times (1.2)^3 = 4320$$

Note that $(1.2)^3 = 1.728 = 172.8\%$, which means that three increases by 20% each are equivalent to one increase by 72.8%.

Worked example 1.3.5

A number 3200 has been decreased by $p\%$ twice. The resulting number is 2312. Calculate p .

We start by setting up the equation:

$$3200 \times \left(1 - \frac{p}{100}\right)^2 = 2312$$

This gives:

$$\left(1 - \frac{p}{100}\right)^2 = 0.7225$$

And we get $1 - \frac{p}{100} = 0.85$, so $p = 15$

Exercise 1.3.5a

A number a has been decreased by $p\%$ twice. The resulting number is b . Find p for the following values of a and b .

(a) $a = 500, b = 245$,

(b) $a = 6, b = 4.6464$,

(c) $a = 72, b = 64.98$.

Exercise 1.3.5b

A number a has been increased by $p\%$ twice. The resulting number is b . Find p for the following values of a and b .

(a) $a = 440, b = 532.4$,

(b) $a = 8, b = 13.52$,

(c) $a = 0.5, b = 1.805$.

Exercise 1.3.5c

A number a has been increased by $p\%$ and then decreased by $p\%$. The resulting number is b . Find p for the following values of a and b .

(a) $a = 700, b = 693$,

(b) $a = 15, b = 11.25$,

(c) $a = 0.06, b = 0.0114$.

Worked example 1.3.6

The width of a rectangle has been increased by 30% while its length has been decreased by 20%. Find the percentage change of the area of the rectangle.

The initial area is $A_{old} = w \times l$, the new area is $A_{new} = 1.3w \times 0.8l$. Then we have:

$$\frac{A_{new}}{A_{old}} = \frac{1.3w \times 0.8l}{w \times l} = 1.04$$

The new area is 104% of the old area, so the area increased by 4%.

Exercise 1.3.6a

The width and the length of a rectangle has been decreased by 40% and 50% respectively. Find the percentage change of the area of the rectangle.

Exercise 1.3.6b

The width and the length of a rectangle has been increased by 5% and 10% respectively. Find the percentage change of the area of the rectangle.

Exercise 1.3.6c

The width of a rectangle has been decreased by 20%. By what percentage should the length increase, so that the area remains unchanged?

Exercise 1.3.6d

The width of a rectangle has been increased by 10%. By what percentage should the length increase, so that the area increases by 30%?

Exercise 1.3.6e

The length of a side of a square increased by 10%. By what percentage has the area increased?

Exercise 1.3.6f

By what percentage does the side-length of a square need to increase in order for the area to increase by 44%?

Exercise 1.3.6g

By what percentage does the side-length of a square need to decrease in order for the area to decrease by 51%?

Worked example 1.3.7

A solution contains 30% alcohol. 100 mL of water is added to 200 mL of this solution. What is the new percentage concentration of alcohol in the diluted solution?

Initially there was $30\% \times 200 = 60$ mL of alcohol and 140 mL of water. The amount of alcohol has not changed, but the amount of water has increased to 240 mL, which means that the total amount of the solution is now 300 mL. So the new percentage concentration of alcohol is:

$$\frac{60}{300} \times 100\% = 20\%$$

Exercise 1.3.7a

You need to create 800 mL of a 12% saline solution using a 20% saline solution and pure water. How much of each component should you use?

Exercise 1.3.7b

You have 300 mL of an 8% alcohol solution and you want to dilute it to make a 5% alcohol solution. How much water should you add?

Exercise 1.3.7c

You mixed 400 mL of a 25% acid solution with 600 mL of a 10% acid solution. What is the concentration of acid in the resulting mixture?

Exercise 1.3.7d

A mixture contains 30% alcohol and the rest water. If a sample of 500 mL of this mixture is diluted with 200 mL of water, what is the new percentage of alcohol in the diluted mixture?

Exercise 1.3.7e

A club has 180 members, 60% of whom are men. If the number of men increased by 10% and the number of women increased by 20%, what is the new total number of members?

Exercise 1.3.7f

A company planned to increase its workforce by 25%. However, due to budget cuts, only 60% of the planned hires were made. If the current workforce is 400 employees, how many new employees were actually hired?

Exercise 1.3.7g

A factory's production cost per unit decreases by 0.5% each time the production volume increases by 1%. If the initial cost per unit is \$50 and the factory increases its production from 1,000 to 1,650 units, what is the new cost per unit?

Exercise 1.3.7h

An investor's portfolio consists of three investments. Investment A comprises 40% of the total portfolio and grows by 8% annually. Investment B comprises 35% of the portfolio and grows by 5% annually. Investment C comprises 25% of the portfolio and decreases by 3% annually. If the total portfolio value is \$50,000, what will be the value of the portfolio after 2 years?

Percentage points and basis points

The support for a certain political party increased from 40% to 45%.

1. Is it true that the support increased by 5%?
2. By what percentage has the support increased?

Percentage points represent the unit of a difference between two percentages.

The support for a certain political party was 40%.

4. Find the support for this party, if it increased by 10%.
5. Find the support for this party, if it increased by 10 *percentage points*.

The inflation recorded in January and February was 3.25% and 3.30% respectively.

A **basis point** is one hundredth of a percentage point.

6. How did the inflation change. Give your answer using % and using *basis points*.
7. Try to find an example in the media where % was incorrectly used instead of *percentage points* or *basis points*.

Note that the Ti-84 does not have an % sign button. This means that when you need to use percentages, you need to turn them into decimals.

EXAMPLE 1

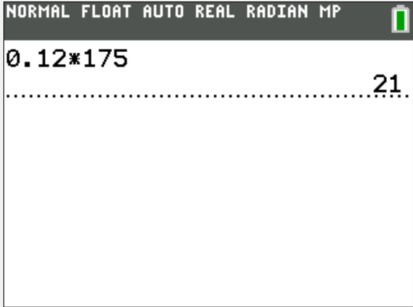
<p>Calculate 12% of 175</p>	<p style="text-align: center;">INPUT</p> 	<p style="text-align: center;">OUTPUT</p> 
---------------------------------	---	---

EXAMPLE 2

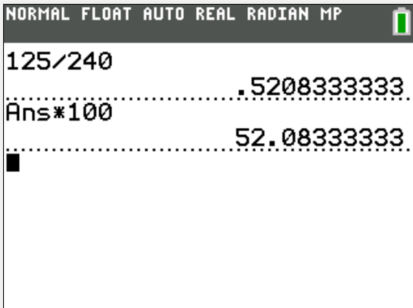
<p>What per- centage of 240 is 125?</p>	<p style="text-align: center;">INPUT</p> 	<p style="text-align: center;">OUTPUT</p> 
---	---	---

EXAMPLE 3

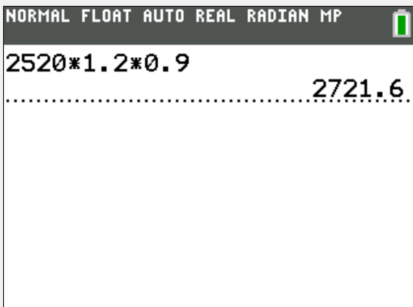
<p>The price of 2520 has been in- creased by 20% and then de- creased by 10%. Find the final price.</p>	<p style="text-align: center;">INPUT</p> 	<p style="text-align: center;">OUTPUT</p> 
---	---	---

SHORT TEST

1. [2 points]

Calculate:

(a) a number whose 85% is 119,

(b) what percentage of 0.042 is 0.002.

2. [3 points]

Price of an item has been increased by $p\%$ and then decreased by $p\%$. Find the value of p , if the initial price was \$1200 and the final price is \$1053.

3. [3 points]

The length of a rectangle has been decreased by 40%. By what percentage does the width need to increase in order for the area to remain constant?

4. [4 points]

What is the percentage concentration of acid in a solution which is a mixture of 200 mL of a 20% acid solution, 300 mL of a 10% solution and 500 mL of a 5% solution.

1.4 Financial Mathematics and Exponential Growth

We will consider two types of interests on the capital invested. **Simple interest** means that a **fixed amount** is added each compounding period. **Compound interest** means that a **fixed percentage** is added each compounding period.

Worked example 1.5.1

Find the value after 3 years of \$2000 investment into savings account that pays 5% annual interest rate which is:

- (a) simple,
- (b) compound.

(a) For simple interest fixed amount is added each year. We have:

$$5\% \text{ of } 2000 = 100$$

which means that each year \$100 is added to the account. After 3 years the total amount in the account will be:

$$2000 + 3 \times 100 = 2300$$

(b) Each year the amount in the account is increased by 5%. An increase by 5% is equivalent to multiplying by 1.05. So after 3 years the amount in the account is:

$$2000 \times 1.05 \times 1.05 \times 1.05 = 2000 \times 1.05^3 = 2315.25$$

Note that in case of the compound interest the amount added to the account each year changes. In the example above in the first year the amount added is 5% of \$2000 which is \$100, but the amount added in the second year is 5% of \$2100 which is \$105.

Exercise 1.5.1 Let PV (present value) be the amount invested, N the number of years and i the annual percentage interest rate. Find the FV (future value), the value of the investment after N years, for the following values of PV , N and i . Consider two cases (i) simple interest, (ii) compound interest.

(a) $PV = \$30\,000, N = 2, i = 6$

(b) $PV = \$100\,000, N = 4, i = 4$

(c) $PV = \$5\,000, N = 6, i = 10$

(d) $PV = \$120\,000, N = 10, i = 1$

(a) $PV = \$18\,000, N = 5, i = 7$

(b) $PV = \$1\,000\,000, N = 8, i = 5$

(a) $PV = \$25\,000, N = 30, i = 3$

(b) $PV = \$140\,000, N = 15, i = 2$

(a) $PV = \$12\,000, N = 4, i = 12$

(b) $PV = \$250\,000, N = 20, i = 6$

Compound interest may not necessarily be compounded once a year. However in most cases the **annual** interest rate is given. This means that you must adjust the interest rate per compounding period.

The future value FV after N years of an investment of PV into savings account that pays $i\%$ annual interest year which is compounded k times per year is:

$$FV = PV \times \left(1 + \frac{i}{k \times 100}\right)^{kN}$$

Worked example 1.5.2

\$120 000 is invested into savings account that pays 8% annual interest rate which is compounded every quarter. Find the value of the investment after 5 years.

8% is the annual interest rate, but because it is compounded quarterly (and there are 4 quarters in a year) every quarter the savings increase by $\frac{8\%}{4} = 2\%$. Now there are 20 quarters in 5 years, so the future value of the investment is:

$$120000 \times 1.02^{20} \approx 178313.69$$

You can also simply substitute the given values into the formula. We have $PV = 120000$, $N = 5$, $i = 8$ and $k = 4$, so:

$$FV = 120000 \times \left(1 + \frac{8}{4 \times 100}\right)^{4 \times 5} \approx 178313.69$$

Exercise 1.5.2a \$120 000 is invested into savings account that pays an annual interest rate of 6%. Find the future value of the investment after 5 years, if the interest is compounded:

- (a) yearly (b) every 6 months (c) monthly

Exercise 1.5.2b \$10 000 is invested into savings account that pays an annual interest rate of 2%. Find the future value of the investment after 30 years, if the interest is compounded:

- (a) every 6 months (b) every 4 months (c) quarterly

Exercise 1.5.2c \$50 000 is invested into savings account that pays an annual interest rate of 4%. Find the future value of the investment after 10 years, if the interest is compounded:

- (a) quarterly (b) every 4 months (c) monthly

Exercise 1.5.2d \$250 000 is invested into savings account that pays an annual interest rate of 10%. Find the future value of the investment, if the interest is compounded:

- (a) monthly (b) every day (c) every second

Worked example 1.5.3

\$20 000 is invested into savings account. The interest on the account is compounded monthly. Find the minimum annual interest rate required for the amount in the account to double in 7 years.

Let $i\%$ be the annual interest rate. We want:

$$20000 \times \left(1 + \frac{i}{12 \times 100}\right)^{12 \times 7} = 40000$$

Simplifying we get:

$$\left(1 + \frac{i}{1200}\right)^{84} = 2$$

So $1 + \frac{i}{1200} = \sqrt[84]{2}$, which gives $i \approx 9.95$.

Note that a more accurate answer is $i = 9.9430700\dots$ and we round this answer up to 9.95, not down to 9.94, as an interest of 9.94% would not be enough for the money to double.

Exercise 1.5.3a \$35 000 is invested into savings account. The interest on the account is compounded k times per year. Find the minimum annual interest rate required for the amount in the account to double in N years for the following values of k and N

(a) $k = 2, N = 10$

(b) $k = 4, N = 12$

(c) $k = 6, N = 8$

Exercise 1.5.3b \$24 000 is invested into savings account. The interest on the account is compounded k times per year. Find the minimum annual interest rate required for the amount in the account to triple in N years for the following values of k and N

(a) $k = 1, N = 20$

(b) $k = 6, N = 25$

(c) $k = 12, N = 40$

EXPONENTIAL GROWTH & DECAY

Worked example 1.5.4

The population of a certain town is increasing by 10% each year. The current population is 40 000. Find the population of the town:

(a) in 4 years,

(b) 5 years ago.

Each year the population increases by 10%, which is equivalent to multiplying by 1.1.

(a) We have:

$$40000 \times 1.1^4 = 58564$$

(b) Let x be the population 5 years ago, then we have:

$$x \times 1.1^5 = 40000$$

$$\text{So } x = \frac{40000}{1.1^5} \approx 24837$$

Exercise 1.5.4a The number of visitors to a website increases by 25% each month. The current number of visitors is 2,000. Find the number of visitors after 6 months.

Exercise 1.5.4b The cost of tuition at a university increases by 9% each year. The current tuition cost is \$15,000. Find the cost of tuition in 4 years.

Exercise 1.5.4c The population of a town decreases by 3% each year. The current population is 30,000. Find the population of the town in 10 years.

Exercise 1.5.4d The number of downloads of a certain app increases by 20% each week. The current number of downloads is 600. Find the number of downloads

(a) after 6 weeks,

(b) last week.

Exercise 1.5.4e The amount of a certain drug in the bloodstream decreases by 18% every hour. The current amount is 150 mg. Find the remaining amount of the drug in the bloodstream

(a) after 7 hours,

(b) 3 hours ago.

Exercise 1.5.4f The price of a computer model decreases by 8% each year. The current price of the computer is \$1,200. Find the price of the computer:

(a) in 5 years,

(b) 2 years ago.

Rule of 72

1. List all positive divisors of 72.
2. An initial population of 10 000 grows by 4% per year. Find the population after 17 years, after 18 years and after 19 years. Approximately how many years it takes for the population to double? Note that $\frac{72}{4} = 18$.
3. An initial population of 25 000 grows by 6% per year. Find the population after 11 years, after 12 years and after 13 years. Approximately how many years it takes for the population to double? Note that $\frac{72}{6} = 12$.
4. An initial population of 32 000 grows by 8% per year. Find the population after 8 years, after 9 years and after 10 years. Approximately how many years it takes for the population to double? Note that $\frac{72}{8} = 9$.
5. An initial population of 15 000 grows by 9% per year. Find the population after 7 years, after 8 years and after 9 years. Approximately how many years it takes for the population to double? Note that $\frac{72}{9} = 8$.
6. Repeat the above calculations for any value of initial population and growth rate of 12%, 15%, 18% and 20%. What do you notice?
7. State the conclusion of your investigation.

Note that the rule of 72 gives you an approximate doubling time. It is useful for quick back-of-the-envelope calculations. On the test you should use more accurate methods.

By far the quickest way to solve financial problems is to use the FINANCE APP on the GDC. All you do is input the data into the GDC and solve for the unknown. You need to remember the meaning of the following:

N number of periods,

I% annual interest rate,

PV present value,

PMT payments,

FV future value,

P/Y periods per year,

C/Y compounding per year,

At this point we won't be using PMT - these are payments (or withdrawals) made during the investment. For now we will always have $PMT = 0$. Periods are related to payments. If you make payments (or withdrawals) every month, then your period is a month (and hence $P/Y = 12$ as there are 12 months in a year). However, as we have $PMT = 0$, we can choose our period to be anything. The two most natural choices are setting the period to be a year (and then $P/Y = 1$) or setting the period to be equal to the compounding time (and then $P/Y = C/Y$).

You should also remember that the GDC indicates the direction of money with the sign. In other words if we pay \$1000 into the account this should be indicated as -1000 (negative). If we withdraw \$1000, then this is 1000 (positive).

EXAMPLE 1

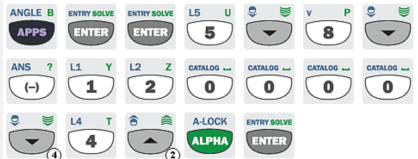
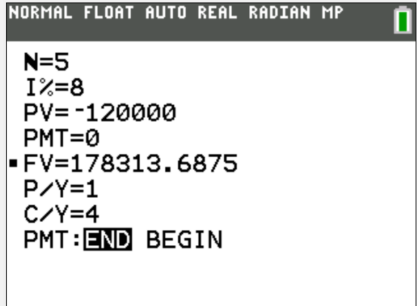
	INPUT	OUTPUT
<p>\$120 000 is invested into savings account that pays 8% annual interest rate which is compounded every quarter. Find the value of the investment after 5 years.</p>		

Note that PV is negative as we initially give away the money to the bank. Note also that $C/Y = 4$, as the interest is compounded 4 times a year.

We could have taken a different approach and let our period be a quarter. In this case we would input:

EXAMPLE 2

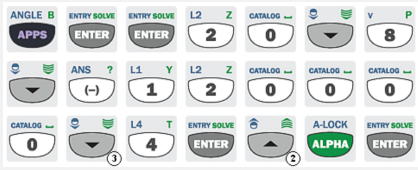
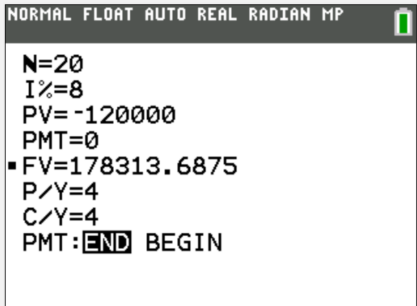
<p>\$120 000 is invested into savings account that pays 8% annual interest rate which is compounded every quarter. Find the value of the investment after 5 years.</p>	<p>INPUT</p> 	<p>OUTPUT</p> 
--	---	---

Notice that we must now have $N = 20$ as our period is a quarter and there are 20 quarters in 5 years. The FV we get is of course the same as in the previous example.

We can use the FINANCE APP to solve for other unknowns, not just the future value. This is illustrated in the next examples.

EXAMPLE 3

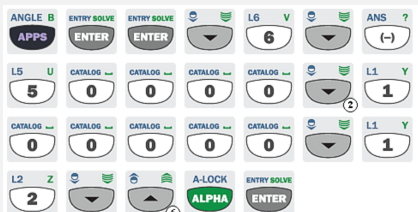
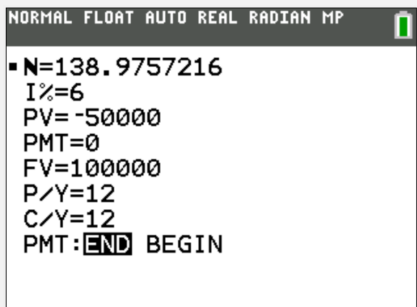
<p>\$50 000 is invested into savings account that pays 6% annual interest rate which is compounded every month. How long does it take for the money to double?</p>	<p>INPUT</p> 	<p>OUTPUT</p> 
--	---	---

FV was set to 100 000 (positive) as we want to be able to withdraw twice the invested amount. Note that the answer $N = 138.975\dots$ means that it takes 139 **months** (P/Y was set to 12) for the money to double.

EXAMPLE 4

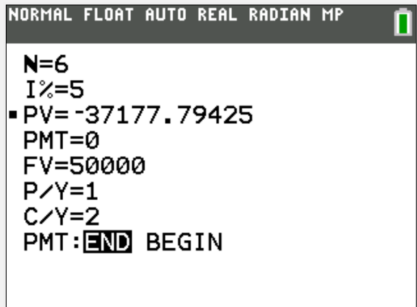
<p>How much needs to be invested into savings account that pays 5% annual interest rate compounded every 6 months in order to have \$50 000 after 2 years?</p>	<p>INPUT</p> 	<p>OUTPUT</p> 
--	---	---

The required amount is \$37177.80. Note that \$37177.79 would not be enough, so we need to round up.

EXAMPLE 5

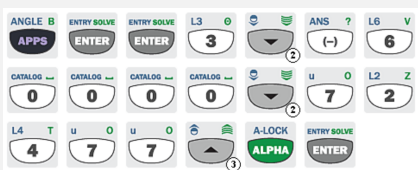
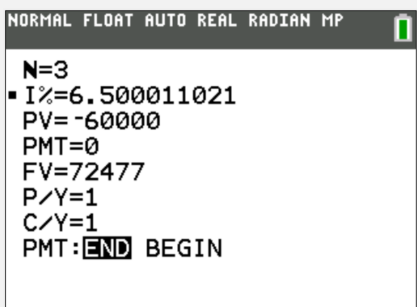
<p>\$60 000 is invested into savings account that pays an annual interest rate compounded yearly. What is the interest rate if there are \$72 477 in the account after 3 years?</p>	<p>INPUT</p> 	<p>OUTPUT</p> 
---	---	---

The required interest rate is approximately 6.5%.

When solving exponential growth problems a table of values is a useful tool.

EXAMPLE 5

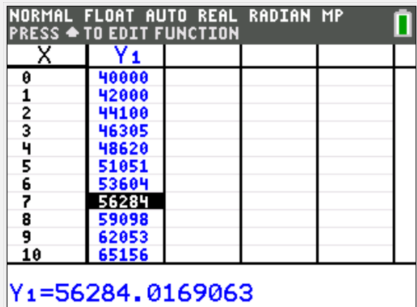
<p>A population of 40 000 increases by 5% each year. Find the population after 7 years.</p>	<p>INPUT</p> 	<p>OUTPUT</p> 
---	---	---

The population after 7 years is approximately 56284.

EXAMPLE 5

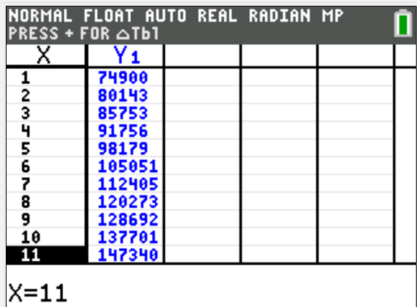
<p>A population of 70 000 increases by 7% each year. After how many years will the population double?</p>	<p>INPUT</p> 	<p>OUTPUT</p> 
---	--	--

It takes 14 years for the population to exceed 140 000 (double the initial amount).

SHORT TEST

1. [2 *points*]
\$20 000 is invested into savings account. Find the value of the investment after 6 years, if the annual interest rate is 4% and it is

- (a) simple (b) compound (compounded yearly)

2. [4 *points*]
\$72 000 is invested into savings account that pays 6% annual interest rate compounded monthly.

- (a) Find the value of the investment after 5 years.
(b) Find the number of months required for the value of the investment to double.

3. [4 *points*]
A population of a certain town increases at a rate of 7% per year. The current population is 35 000

- (a) Find the population after 3 years.
(b) How long will it take for the population to exceed 85 000?

SHORT TEST
SOLUTIONS

1. [2 points]
\$20 000 is invested into savings account. Find the value of the investment after 6 years, if the annual interest rate is 4% and it is

- (a) simple (b) compound (compounded yearly)

(a) $20000 \times 4\% = 800$, so after 6 years: $20000 + 6 \times 800 = 24800$

(b) $20000 \times (1.04)^6 = 25406.38$

2. [4 points]
\$72 000 is invested into savings account that pays 6% annual interest rate compounded monthly.

- (a) Find the value of the investment after 5 years.
(b) Find the number of months required for the value of the investment to double.

(a)

NORMAL FLOAT AUTO REAL RADIAN MP	
N=60	
I%=6	
PV=-72000	
PMT=0	
FV=97117.21098	
P/Y=12	
C/Y=12	
PMT:END BEGIN	

\$97117.21

(b)

NORMAL FLOAT AUTO REAL RADIAN MP	
N=138.9757216	
I%=6	
PV=-72000	
PMT=0	
FV=144000	
P/Y=12	
C/Y=12	
PMT:END BEGIN	

139 months

3. [4 points]
A population of a certain town increases at a rate of 7% per year. The current population is 35 000

- (a) Find the population after 3 years. $35000 \times 1.07^3 \approx 42877$
(b) How long will it take for the population to exceed 85 000?

(a)

NORMAL FLOAT AUTO REAL RADIAN MP	
PRESS \rightarrow TO EDIT FUNCTION	
X	Y1
0	35000
1	37450
2	40072
3	42877
4	45878
5	49089
6	52526
7	56202
8	60137
9	64346
10	68850

Y1=42876.505

42877

(b)

NORMAL FLOAT AUTO REAL RADIAN MP	
PRESS \rightarrow FOR Δ Tb1	
X	Y1
7	56202
8	60137
9	64346
10	68850
11	73670
12	78827
13	84345
14	90249
15	96566
16	103326
17	110559

X=14

14 years

1.5 Ratio and proportion

One quantity y **varies directly** with some other quantity x , if there is a constant k such that:

$$y = kx$$

In such cases we may also say that x and y are **directly proportional**. The constant k is often referred to as the constant of proportionality. It is often useful, when solving problems involving directly proportional quantities, to focus on the ratio $\frac{y}{x}$. This ratio is by definition constant.

Worked example 1.5.1

The number of pages a printer can print is directly proportional to the amount of ink available. If 4 ink cartridges can print 1000 pages, how many pages can be printed using 5 ink cartridges?

Let x be the number of cartridges and y be the number of pages printed.

Method 1

The quantities are directly proportional so they satisfy the following equation for some constant k :

$$y = kx$$

We will calculate k using the information in the question:

$$1000 = k \times 4$$

So $k = 250$ and the equation relating y and x is:

$$y = 250x$$

No we want y for $x = 5$ and we get $y = 250 \times 5 = 1250$.

Method 2

The quantities are directly proportional so the ratio $\frac{y}{x}$ is constant, which means that:

$$\frac{1000}{4} = \frac{y}{5}$$

Solving the above gives $y = 1250$.

Exercise 1.5.1a A company pays its employees based on the number of hours worked. If an employee earns \$120 for working 15 hours, how much will the employee earn for working 19 hours at the same rate?

Exercise 1.5.1b The brightness level of a light bulb is directly proportional to the electrical current passing through it. If a current of 2 amperes produces a brightness level of 76 lumens, how many lumens will be produced by a current of 3 amperes?

Exercise 1.5.1c The number of phone calls made from a call center is directly proportional to the number of employees working. If 5 employees can handle 240 calls per hour, how many employees are needed to handle 400 calls per hour?

Exercise 1.5.1d The growth rate of a plant is directly proportional to the amount of sunlight it receives. If a plant grows 2 inches with 5 hours of sunlight, how many inches will it grow with 8 hours of sunlight?

Exercise 1.5.1e The temperature rise in a room is directly proportional to the number of heaters running. If it takes 3 heaters to raise the temperature by 10 degrees Celsius, how many heaters are needed to raise the temperature by 16 degrees Celsius?

One quantity y **varies inversely** with some other quantity x , if there is a constant k such that:

$$y = \frac{k}{x}$$

In such cases we may also say that x and y are **inversely proportional**. Note that when two quantities are inversely proportional, then their product is always constant, that is $xy = k$ for some constant k .

Worked example 1.5.2

The time taken to complete a task is inversely proportional to the number of workers working on the task. If 4 workers can complete a task in 5 hours, how long will it take for 6 workers to complete the same task?

Let t be the time measured in hours and w be the number of workers.

Method 1

The quantities are inversely proportional so they satisfy the following equation for some constant k :

$$t = \frac{k}{w}$$

We will calculate k using the information in the question:

$$5 = \frac{k}{4}$$

So $k = 20$ and the equation relating t and w is:

$$t = \frac{20}{w}$$

No we want t for $w = 6$ and we get $t = \frac{20}{6} = 3\text{h } 40\text{min}$.

Method 2

The quantities are inversely proportional so their product $t \times w$ is constant, which means that:

$$5 \times 4 = t \times 6$$

Solving this for t gives $t = \frac{20}{6} = 3\text{h } 40\text{min}$.

Note that in both instances (direct and inverse proportionality) the second method is much quicker and is recommended, when we only need to calculate one quantity. You need to remember that when two quantities a and b are directly proportional, then their **ratio** is constant and when they are inversely proportional, then their **product** is constant.

Exercise 1.5.2a Quantity p is inversely proportional to quantity q . When $p = 24$, then $q = 5$. Find the value of q , when $p = 10$.

Exercise 1.5.2b The pressure of a gas is inversely proportional to its volume. If a gas occupies a volume of 4 litres at a pressure of 3 atm, what would be the pressure if the volume is reduced to 3 litres?

Exercise 1.5.2c The resistance of a wire of given length is inversely proportional to its cross-sectional area. If a wire with a resistance of 6 ohms has a cross-sectional area of 4 mm^2 , what would the resistance be for a wire with a cross-sectional area of 9 mm^2 ?

Exercise 1.5.2d The frequency of a sound wave is inversely proportional to the wavelength. If a sound wave has a frequency of 400 Hz with a wavelength of 3 meters, what will be the frequency with a wavelength of 2 meters?

Worked example 1.5.3a

The resistance of a wire is directly proportional to its length and inversely proportional to its cross-sectional area. If a wire of length 20 m and cross-sectional area of 2 mm^2 has a resistance of 30 ohms, what will be the resistance of a wire of length 15 m and cross-sectional area of 3 mm^2 ?

Let's represent resistance as R , length as l , and cross-sectional area as A .

Method 1

The formula for R will have l in the numerator (as R is directly proportional to l) and A in the denominator (as R is inversely proportional to A):

$$R = k \times \frac{l}{A}$$

Substituting the given values we get:

$$30 = k \times \frac{20}{2}$$

which gives $k = 3$ and the equation for R is:

$$R = 3 \times \frac{l}{A}$$

now for $l = 15$ and $A = 3$ we get $R = 3 \times \frac{15}{3} = 15$ ohms.

Method 2

We start by fixing A at 2 mm^2 . Now R is directly proportional to l , so:

$$\frac{30}{20} = \frac{R}{15}$$

Which gives $R = 22.5$, so a wire of length $l = 15$ m and $A = 2 \text{ mm}^2$ has resistance of 22.5 ohms. Now we fix l at 15 m. R is inversely proportional to A , so:

$$22.5 \times 2 = R \times 3$$

which gives $R = 15$ ohms.

Worked example 1.5.3b

If 5 workers can assemble 200 products in 4 hours, how many products can 8 workers assemble in 6 hours?

Let's represent the number of workers as w , number of products assembled as p and time as t . We assume that for fixed w , p is directly proportional to t and for fixed t it is directly proportional to w

Method 1

We have the following formula:

$$p = k \times w \times t$$

Substituting the given values we get:

$$200 = k \times 5 \times 4$$

this gives $k = 10$ and we get the following equation for p is:

$$p = 10 \times w \times t$$

now for $w = 8$ and $t = 6$ we get $p = 10 \times 8 \times 6 = 480$ products.

Method 2

We fix w at 5. Now p is directly proportional to t , so:

$$\frac{200}{4} = \frac{p}{6}$$

Which gives $p = 300$, which means that 5 workers will assemble 300 products in 6 hours. Now we fix t at 6 h. p is directly proportional to w , so:

$$\frac{300}{5} = \frac{p}{8}$$

which gives $p = 480$ products.

Exercise 1.5.3a The temperature of a gas is directly proportional to its pressure and inversely proportional to its volume. If the pressure of the gas is 4 atm, the temperature is 300 K, and the volume is 2 L, find the temperature when the pressure is 6 atm and the volume is 3 L.

Exercise 1.5.3b Three quantities x , y , and z are related such that x is directly proportional to y and inversely proportional to z . If $x = 10$ when $y = 3$ and $z = 5$, find the value of x when $y = 6$ and $z = 4$.

Exercise 1.5.3c Three variables, a , b , and c , are related in a way that a varies directly with b and inversely with c . If when $a = 8$ when $b = 4$ and $c = 10$, find the value of a when $b = 6$ and $c = 25$.

Exercise 1.5.3d Three variables, p , q , and r , are related such that p is directly proportional to q and inversely proportional to r . If $p = 12$ when $q = 6$ and $r = 2$, find the value of p when $q = 8$ and $r = 3$.

Exercise 1.5.3e Three quantities a , b , and c are related such that a is directly proportional to the square root of b and inversely proportional to c . If $a = 20$ when $b = 25$ and $c = 5$, find the value of a when $b = 36$ and $c = 4$.

Exercise 1.5.3f If 5 carpenters can build 4 chairs in 8 hours, how many chairs can 3 carpenters build in 6 hours?

Exercise 1.5.3g If 2 chefs can bake 100 cakes in 5 hours, how many cakes can 3 chefs bake in 8 hours?

Exercise 1.5.3h If 3 painters can paint 2 rooms in 4 hours, how many rooms would 4 painters paint in 6 hours?

Exercise 1.5.3i If 4 machines can produce 300 units in 5 hours, how many units can 6 machines produce in 8 hours?

Exercise 1.5.3j* Suppose u , v , and w are related such that u is directly proportional to \sqrt{v} and inversely proportional to w . If $u = 16$ when $v = 25$ and $w = 4$, determine the value of u when $v = 36$ and $w = 6$.

Exercise 1.5.3k* The force experienced by an object is directly proportional to the mass and inversely proportional to the square of the distance from the source of the force. If a 4 kg object feels a force of 20 N at a distance of 2 m, what force will a 6 kg object feel at a distance of 3 m?

Exercise 1.5.3l* The brightness of a light source is directly proportional to the power of the source and inversely proportional to the square of the distance from the source. If a 100 W light bulb is 4 meters away and has a brightness of 25 lumens, what distance would produce a brightness of 64 lumens with a 150 W light bulb?

Exercise 1.5.3m* The speed of sound in air is directly proportional to the square root of the temperature and inversely proportional to the square root of the density of air. If the speed of sound is 340 ms^{-1} when the temperature is 25°C and the air density is 1.2 kgm^{-3} , what will be the speed of sound when the temperature is 35°C and the air density is 1.5 kgm^{-3} ?

When dividing a certain quantity into several parts that are in a given ratio, it is recommended to introduce an auxiliary variable that represents the smallest part required for the division. For example when we want to divide a certain quantity into two parts in ratio 2 : 7, the first part will be equal to $2x$, the second part will be equal $7x$ and the total is equal to $9x$.

Worked example 1.5.4a

Divide 81 into 3 parts in ratio 2 : 3 : 4.

The first part is $2x$, the second part is $3x$ and the third part is $4x$. This gives the total of $9x$. We have:

$$9x = 81$$

which gives $x = 9$, so the three parts are 18, 27 and 36.

Worked example 1.5.4b

The angles in a triangle are in a ratio of 2 : 9 : 13. Calculate the size of the smallest angle.

The angles are $2x$, $9x$ and $13x$. The total is $24x$ and it has to be equal to 180° :

$$24x = 180^\circ$$

So $x = 7.5^\circ$ and the smallest angle is $2x$ which is 15° .

Exercise 1.5.4a Divide 120 in the ratio:

3 : 5 : 10

1 : 8 : 11

2 : 5 : 11 : 14

Exercise 1.5.4b The angles in a triangle are in the ratio 3 : 5 : 7. Find the size of the largest angle.

Exercise 1.5.4c The angles in a quadrilateral are in the ratio 2 : 5 : 6 : 7. Find the size of the smallest angle.

Exercise 1.5.4d A school committee is made up of teachers, parents, and students in the ratio 2:3:4. If there are a total of 45 members in the committee, determine how many members belong to each group.

Exercise 1.5.4e A school committee is made up of teachers, parents, and students in the ratio 2 : 3 : 4. If there are a total of 20 students on in the committee, determine how many members are there in total.

Exercise 1.5.4f Suppose a certain amount of money is divided among three people, X, Y, and Z, in the ratio 2 : 3 : 5. If person Y received \$120 more than person X, calculate how much each person received.

Exercise 1.5.4g A certain amount of money is divided among four people, A, B, C, and D, in the ratio $3 : 5 : 7 : 9$. If person B received \$360 more dollars than person A, calculate how much each person received.

Exercise 1.5.4h Three siblings divide a collection of toys in the ratio $2 : 5 : 8$. If the second sibling has 9 more toys than the first sibling, determine the number of toys each sibling receives.

Exercise 1.5.4i A fruit basket contains apples, oranges, and bananas in the ratio $3 : 4 : 7$. If the number of bananas is 12 more than the number of apples, find the quantity of each fruit in the basket.

Exercise 1.5.4j Four friends decide to share a box of chocolates in the ratio $1 : 2 : 3 : 4$. If the friend with the most chocolates has 15 more than the friend with the least, calculate how many chocolates each friend receives.

Exercise 1.5.4k In a painting competition, the ratio of the number of paintings submitted by students X, Y, and Z is $7 : 9 : 11$. If Z submitted 10 fewer paintings than the combined number of paintings submitted by X and Y, find the number of paintings each student submitted.

Exercise 1.5.4l A school awards scholarships to students in the ratio $2:3:7$ for art, sports, and academic achievements. If the scholarship for academic achievements is \$100 more than combined scholarships for arts and sports achievements, find the scholarship amount for each category.

Golden rectangle

Consider a square $ABCD$ of side-length 1:

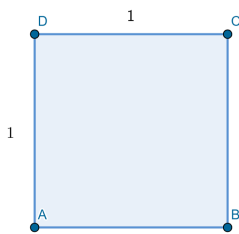

1. Let E be the midpoint of the line segment AB . Find the length of DE .

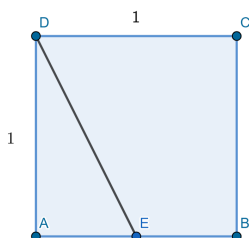

2. Draw a circle centered at E of radius equal to the length of DE . Let F be the point where the circle meets the half-line AB . Find the length of AF

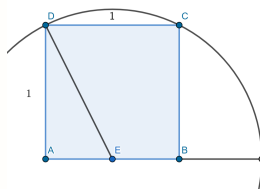

3. Draw a rectangle $AFGD$. What are the lengths of its sides?

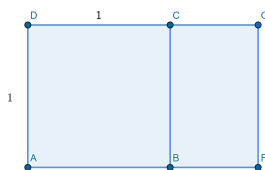

4. Find the ratio of the length of the longer side to the length of the shorter side for rectangles $AFGD$ and $BFGC$. What do you notice?

These rectangles are called **golden rectangles** and the ratio of their sides is $\phi = \frac{1+\sqrt{5}}{2} \approx 1.61803$, which is known as the **golden ratio**.

To solve $\frac{5}{x} = \frac{2}{3}$ we can simply rearrange this equation and find that $15 = 2x$, so $x = 7.5$. We can however solve this equation directly on the GDC.

EXAMPLE 1

<p>Solve:</p> $\frac{5}{x} = \frac{2}{3}$	<p>INPUT</p>	<p>OUTPUT</p>
--	---------------------	----------------------

When solving an equation in Numeric Solver you need to remember several things:

- you need to input both sides of the equation and use x as your unknown,
- the initial value assigned to x (in the above example I set $x = 6$) is the place where your calculator will start looking for solutions. Make sure that this initial value is sensible and does not lead to problems. In the example above we cannot start with $x = 0$ as this leads to division by 0.
- the bounds indicate the interval in which your calculator will look for solutions. You may change them, if you are interested only in a solution in a certain interval.
- beware that the GDC will only give you one solution at a time. If an equation has more than one solution, you may need to look for them by changing the initial value of x or the bounds.

EXAMPLE 2

<p>Solve:</p> $x^2 = 25$	<p>INPUT</p>	<p>OUTPUT</p>
---------------------------------	---------------------	----------------------

In the previous example the GDC gave us only one solution. You can change the initial value of x to find the other one.

EXAMPLE 3

Solve:	INPUT	OUTPUT
<p>$x^2 = 25$</p>		<p>NORMAL FLOAT AUTO REAL RADIAN MP SOLUTION IS MARKED *</p> <p>$X^2=25$</p> <ul style="list-style-type: none"> ▪ $X = -5$ bound = { -1E99, 1E99 } ▪ $E1-E2=0$

SHORT TEST

1. [2 points]
Two quantities x and y are such that when $x = 8$, then $y = 20$. Find y , when $x = 6$, given that x and y are

(a) directly proportional

(b) inversely proportional

2. [4 points]
Three variables, a , b and c , are related in a way that a varies directly with b and inversely with c . If $a = 20$ when $b = 5$ and $c = 4$, find the value of a when $b = 8$ and $c = 3$.

3. [2 points]
Divide 60 in the ratio:

(a) $2 : 3 : 7$

(b) $1 : 5 : 5 : 7$

4. [4 points]
The inheritance was divided among 4 heirs in the ratio $2 : 3 : 5 : 10$. If the person who received the most received \$4000 more than what the two people who received the least combined, find how much each person received.

**SHORT TEST
SOLUTIONS**

1. [2 points]
Two quantities x and y are such that when $x = 8$, then $y = 20$. Find y , when $x = 6$, given that x and y are

(a) directly proportional

(b) inversely proportional

(a) $\frac{20}{8} = \frac{y}{6}$, so $y = 15$

(b) $20 \times 8 = y \times 6$, so $y = 26\frac{2}{3}$

2. [4 points]
Three variables, a , b and c , are related in a way that a varies directly with b and inversely with c . If $a = 20$ when $b = 5$ and $c = 4$, find the value of a when $b = 8$ and $c = 3$.

Fix c . We have:

$$\frac{20}{5} = \frac{a}{8}$$

which gives $a = 32$ (when $b = 8$ and $c = 4$). Now fix b :

$$32 \times 4 = a \times 3$$

which gives $a = 42\frac{2}{3}$.

3. [2 points]
Divide 60 in the ratio:

(a) 2 : 3 : 7

(b) 1 : 5 : 5 : 7

(a) $2x + 3x + 7x = 12x$, so $12x = 60$

(b) $x + 5x + 5x + 7x = 18x$, $18x = 60$

this gives $x = 5$ and the parts are

so $x = 3\frac{1}{3}$ and we get

10, 15 and 35

$3\frac{1}{3}$, $16\frac{2}{3}$, $16\frac{2}{3}$ and $23\frac{1}{3}$

4. [4 points]
The inheritance was divided among 4 heirs in the ratio 2 : 3 : 5 : 10. If the person who received the most received \$4000 more than what the two people who received the least combined, find how much each person received.

The amounts the heirs received are $2x$, $3x$, $5x$ and $10x$. We have:

$$2x + 3x + 4000 = 10x$$

This gives $x = 800$, so the amounts each person received are \$1600, \$2400, \$4000 and \$8000.

1.6 Approximation and rounding

A natural number can be written as a sum of multiples of powers of tens. For example we have:

$$7532 = 7 \times 10^3 + 5 \times 10^2 + 3 \times 10^1 + 2 \times 10^0$$

So 7532 consists of 7 thousands, 5 hundreds, 3 tens and 2 units:

$$\begin{array}{cccc} \text{thousands} & & \text{tens} & \\ 7 & 5 & 3 & 2 \\ & \text{hundreds} & & \text{units} \end{array}$$

When rounding a number to a given degree of accuracy, if the following digit is 5 or more then round up, otherwise round down.

Worked example 1.6.1

Round the number 4548.7 to the nearest:

- | | |
|---------------|----------|
| (a) thousand, | (a) 5000 |
| (b) hundred, | (b) 4500 |
| (c) ten, | (c) 4550 |
| (d) unit. | (d) 4549 |

Exercise 1.6.1 Round the following numbers to the nearest thousand, hundred, ten and unit:

- | | | | |
|--------------|------------|-------------|-----------|
| (a) 54525.13 | (b) 2742.5 | (c) 3298.53 | (d) 969.9 |
|--------------|------------|-------------|-----------|

You may need to round a number to a given number decimal places (d.p.). These are places after the decimal point.

Worked example 1.6.2

Round the number 3.299543 to:

- | | |
|-------------|------------|
| (a) 1 d.p., | (a) 3.3 |
| (b) 2 d.p., | (b) 3.30 |
| (c) 3 d.p., | (c) 3.300 |
| (d) 4 d.p., | (d) 3.2995 |

Note that the above answers to parts (a), (b) and (c) are equal in value, but they represent different degree of accuracy. 3.3 indicates that the original value could be any number between 3.25 and 3.35, while 3.30 indicate that the original value was between 3.295 and 3.305.

Exercise 1.6.2 Round the following numbers to 1 d.p., 2 d.p., 3 d.p., and 4 d.p.:

(a) 13.257814

(b) 0.074691

(c) 1.599421

(d) 0.598993

Significant figures (s.f.) are counted started from the first non-zero from the left and counting every digit after that. Consider the numbers 3026 and 0.06709. We have:

$\overset{3}{1^{st} \text{ s.f.}}$ $\overset{0}{2^{nd} \text{ s.f.}}$ $\overset{2}{3^{rd} \text{ s.f.}}$ $\overset{6}{4^{th} \text{ s.f.}}$ and 0 . 0 $\overset{6}{1^{st} \text{ s.f.}}$ $\overset{7}{2^{nd} \text{ s.f.}}$ $\overset{0}{3^{rd} \text{ s.f.}}$ $\overset{9}{4^{th} \text{ s.f.}}$

Worked example 1.6.3

Round the following number to 3 significant figures:

(a) 2.54678,

(a) 2.55

(b) 987320,

(b) 987000

(c) 4599900,

(c) 4600000

(d) 0.000429932.

(d) 0.000430

Note that in example (c) the number is rounded to 3 s.f., but this isn't immediately obvious by looking at the number (it could have been rounded to 2 s.f. instead).

Exercise 1.6.3 Round the following numbers to 1 s.f., 2 s.f., 3 s.f. and 4 s.f.:

(a) 29.457

(b) 395.042

(c) 529275

(d) 0.0269532

(e) 7992305

(f) 0.00549928

(g) 1.00392

(h) 20.04992

Rounding can be used to quickly approximate answers to certain calculations. Consider the multiplication 28×73 . If we round each term to one significant figure we get $28 \times 73 \approx 30 \times 70 = 2100$, which can be easily calculated without the use of a calculator. The exact answer is $28 \times 73 = 2044$, which isn't far off from our approximated answer.

Exercise 1.6.3 Round the numbers involved to 1 s. f. and approximate the following:

(a) 387×19 (b) 0.0792×22 (c) 29.5×1.143 (d) 722×0.38923 (a) $592 \div 29$ (b) $1105 \div 23$ (c) $95 \div 1.897$ (d) $31 \div 6.38$

Worked example 1.6.4

By rounding the lengths to 1 s.f. estimate the volume and surface area of the given solid.

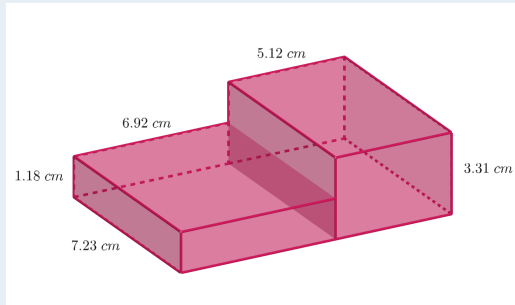

The total volume is a sum of volumes of two cuboids:

$$V \approx 7 \times 7 \times 1 + 7 \times 5 \times 3 = 49 + 105 = 154 \text{ cm}^3$$

The surface area consists of several faces:

$$SA \approx 2 \times 7 \times (7+5) + 2 \times 7 \times 3 + 2 \times 1 \times 7 + 2 \times 3 \times 5$$

The above sum consists of top and bottom faces first, then left and right faces and finally the front and back faces. Finally we get:

$$SA \approx 254 \text{ cm}^2$$

Exercise 1.6.4a

By rounding the lengths to 1 s.f. estimate the areas of the figures below. Diagrams are not to scale.

(a)

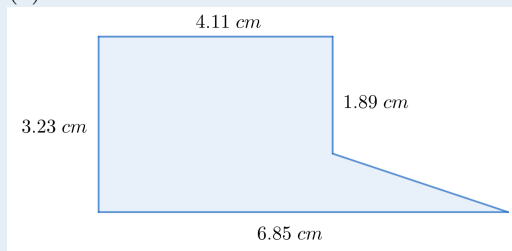

(b)

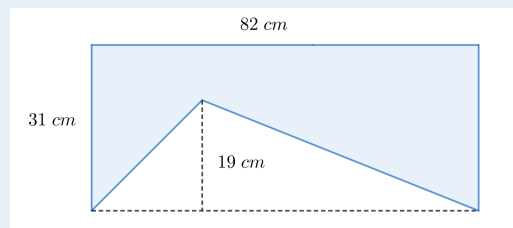

(c)

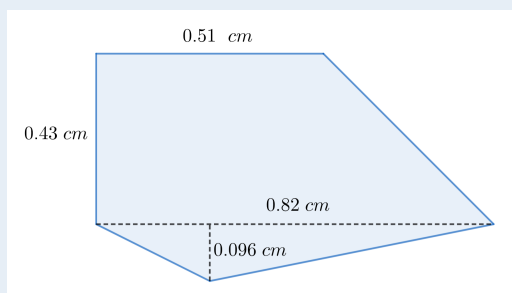

(d)

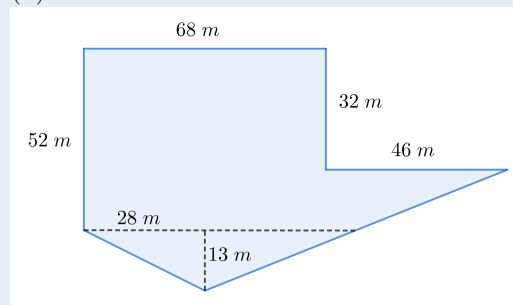

Exercise 1.6.4b

By rounding the lengths to 1 s.f. estimate the volume and surface area of the given solids.

(a)

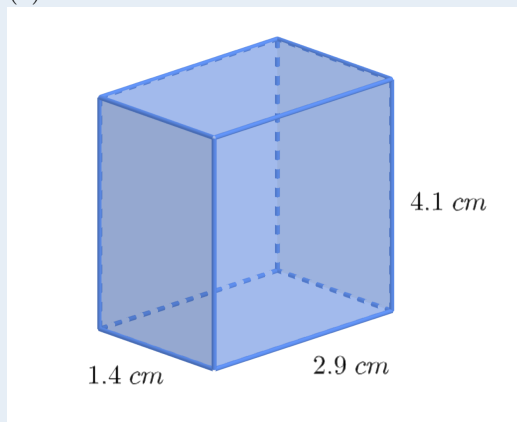

(b)

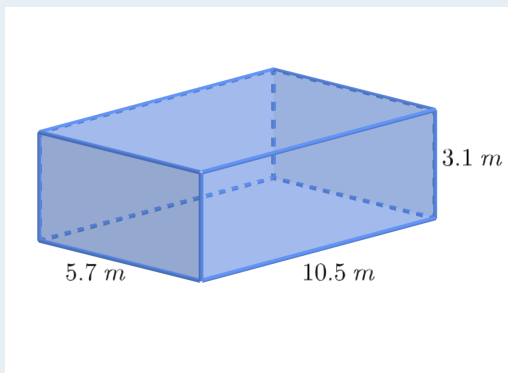

(c)

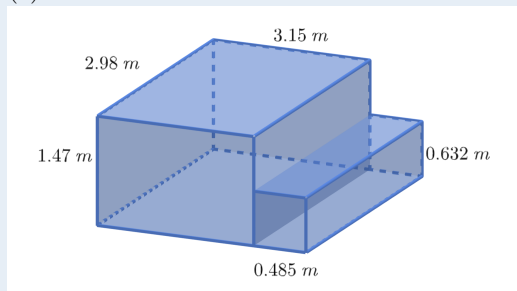

(d)*

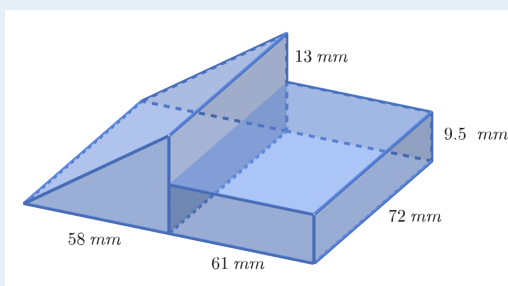

Lower and upper bounds

Suppose a number x when rounded to 1 d.p. is 6.4. This means that we know that

$$6.35 \leq x < 6.45$$

6.35 is the lower bound and 6.45 is the upper bound for x .

1. Find the lower and the upper bound for the number x which when rounded to 1 d.p. is:

(a) 29.5

(a) 0.1

(c) 9.0

2. Find the lower and the upper bound for the number x which when rounded to 2 s.f. is:

(a) 25

(a) 0.023

(c) 75000

3. Find the lower and upper bound of the perimeter and area of a rectangle whose sides are of length 40 *cm* and 50 *cm* both rounded to 1 s.f.

4. Find the lower and upper bound of the volume and surface area of a cuboid with dimensions 2 *m* \times 3 *m* \times 5 *m*, if each measurement was rounded to the nearest metre.

5. Lottery prize is divided equally among a group of people. If the prize is \$500 000 rounded to 1 s.f. and there are approximately 20 (rounded to 1 s.f.) people in the group, find the lower and upper bound of the amount each person receives.

6. Consider the following expression:

$$\frac{y}{x} - \frac{z}{w}$$

Find the lower and upper bound for the value of this expression if

$$x = 20, \quad y = 80, \quad z = 300, \quad w = 200$$

and each number has been rounded to 1 s.f.

The GDC allows you to display numbers rounded to up to 9 decimal places.

EXAMPLE 1

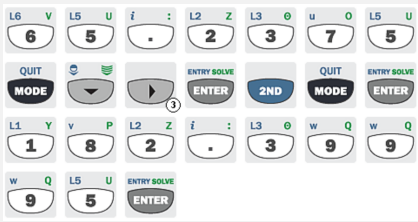
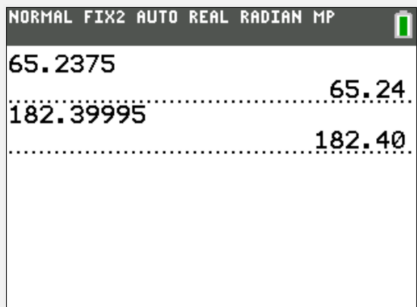
<p>Round the following numbers to 2 d.p.:</p> <p>(a) 65.2375</p> <p>(b) 182.39995</p>	<p style="text-align: center;">INPUT</p> 	<p style="text-align: center;">OUTPUT</p> 
---	---	---

The Ti-84 does not have an option to round to a certain number of significant figures. You can however circumvent this by using standard form (see section 1.8) and using decimal places. Note that 2 d.p. in standard form is equivalent to 3 s.f.

SHORT TEST

1. [2 points]
Round 4597 to the nearest:

(a) hundred

(b) ten

2. [2 points]
Round the following numbers to 2 d.p.:

(a) 97.2993

(b) 0.01293

3. [2 points]
Round the following numbers to 3 s.f.:

(a) 543752

(b) 0.023997

4. [2 points]
Estimate the answer to the following calculations by rounding the numbers to 1 s.f.:

(a) 39×53

(b) $1013 \div 202$

5. [4 points]
By rounding the lengths to 1 s.f. approximate the areas of the figure below. Diagram is not to scale.

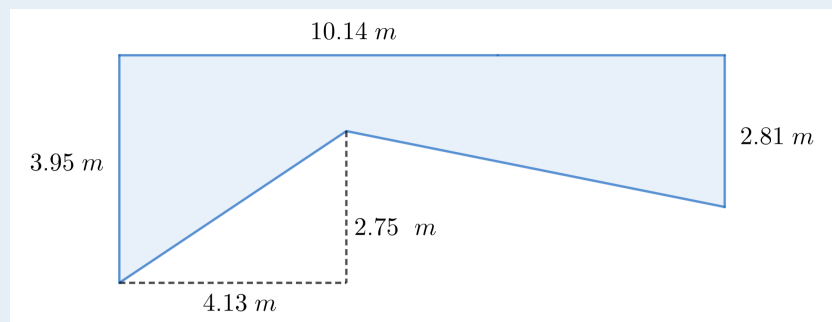

**SHORT TEST
SOLUTIONS**

1. Round 4597 to the nearest: [2 points]

- (a) hundred (b) ten
 (a) 4600 (b) 4600

2. Round the following numbers to 2 d.p.: [2 points]

- (a) 97.2993 (b) 0.01293
 (a) 97.30 (b) 0.01

3. Round the following numbers to 3 s.f.: [2 points]

- (a) 543752 (b) 0.023997
 (a) 544000 (b) 0.0240

4. Estimate the answer to the following calculations by rounding the numbers to 1 s.f.: [2 points]

- (a) 39×53 (b) $1013 \div 202$
 (a) $\approx 40 \times 50 = 2000$ (b) $\approx 1000 \div 200 = 5$

5. By rounding the lengths to 1 s.f. approximate the areas of the figure below. Diagram is not to scale. [4 points]

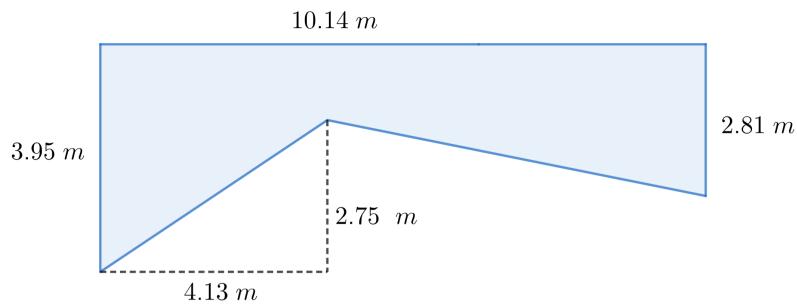

Adding areas of two trapeziums:

$$A \approx \frac{(4+1) \times 4}{2} + \frac{(3+1) \times 6}{2} = 22m^2$$

1.7 Laws of Indices

In this section you will practice applying the laws of indices. Recall that we have the following laws of indices:

1. Product of Powers:

$$a^m \times a^n = a^{m+n}$$

Example: $5^7 \times 5^4 = 5^{7+4} = 5^{11}$

2. Quotient of Powers:

$$\frac{a^m}{a^n} = a^{m-n}, \quad \text{for } a \neq 0$$

Example: $\frac{3^8}{3^6} = 3^{8-6} = 3^2$

3. Power of a Power:

$$(a^m)^n = a^{m \times n}$$

Example: $(7^3)^4 = 7^{3 \times 4} = 7^{12}$

4. Power of a Product:

$$(ab)^n = a^n \times b^n$$

Example: $6^5 = (2 \times 3)^5 = 2^5 \times 3^5$

5. Power of a Quotient:

$$\left(\frac{a}{b}\right)^n = \frac{a^n}{b^n}, \quad \text{for } b \neq 0$$

Example: $0.4^3 = \left(\frac{2}{5}\right)^3 = \frac{2^3}{5^3} = \frac{8}{125}$

6. Zero Exponent:

$$a^0 = 1, \quad \text{for } a \neq 0$$

Example: $(\pi + \sqrt{2} + 13)^0 = 1$

7. Negative Exponent:

$$a^{-n} = \frac{1}{a^n}, \quad \text{for } a \neq 0$$

Example: $2^{-3} = \frac{1}{2^3} = \frac{1}{8}$

8. Fractional Exponents:

$$a^{\frac{m}{n}} = \sqrt[n]{a^m} = (\sqrt[n]{a})^m, \quad \text{for } a \geq 0$$

Example: $8^{\frac{4}{3}} = (\sqrt[3]{8})^4 = 2^4 = 16$

Worked example 1.7.1

Calculate:

$$\frac{32^{\frac{2}{5}} \times 27^{-\frac{5}{3}}}{(2\sqrt{2})^{-2} \times (\sqrt[3]{9})^{-6}}$$

We can start by expressing given numbers as powers of 2 and 3:

$$\frac{(2^5)^{\frac{2}{5}} \times (3^3)^{-\frac{5}{3}}}{(2 \times 2^{\frac{1}{2}})^{-2} \times (\sqrt[3]{3^2})^{-6}}$$

Now we will apply fractional exponents law and power of a power law:

$$\frac{2^2 \times 3^{-5}}{2^{-3} \times 3^{-4}}$$

Finally we apply the quotient of powers law to get:

$$2^5 \times 3^{-1} = \frac{32}{3}$$

Exercise 1.7.1

Calculate:

(a)
$$\frac{32^{\frac{4}{5}} \times 64^{-\frac{2}{3}}}{(8)^{-2} \times (4^{1/2})^{-4}}$$

(b)
$$\frac{27^{\frac{2}{3}} \times 81^{-\frac{3}{4}}}{(9)^{-2} \times (3^3)^{-1}}$$

(c)
$$\frac{25^{\frac{3}{2}} \times 125^{-\frac{4}{3}}}{(5)^{-4} \times (25^{1/2})^{-3}}$$

(d)
$$\frac{8^{\frac{5}{3}} \times 4^{-\frac{7}{2}}}{(2^4)^{-3} \times (16^{1/4})^{-2}}$$

(e)
$$\frac{9^{\frac{4}{2}} \times 27^{-\frac{5}{3}}}{(3^3)^{-1} \times (9^{1/2})^{-4}}$$

(f)
$$\frac{16^{\frac{3}{4}} \times 32^{-\frac{5}{3}}}{(2^6)^{-2} \times (8^{1/3})^{-3}}$$

(g)
$$\frac{64^{\frac{1}{3}} \times 81^{-\frac{1}{4}}}{(3\sqrt{3})^{-2} \times (\sqrt[4]{16})^{-3}}$$

(h)
$$\frac{125^{\frac{2}{3}} \times 36^{-\frac{3}{2}}}{(5\sqrt{5})^{-1} \times (\sqrt[3]{8})^{-4}}$$

(i)
$$\frac{49^{\frac{3}{2}} \times 8^{-\frac{4}{3}}}{(4\sqrt{2})^{-3} \times (\sqrt[5]{32})^{-5}}$$

(j)
$$\frac{100^{\frac{1}{2}} \times 27^{-\frac{2}{3}}}{(2\sqrt{3})^{-4} \times (\sqrt[6]{64})^{-2}}$$

(k)
$$\frac{16^{\frac{3}{4}} \times 128^{-\frac{2}{7}}}{(2\sqrt{2})^{-3} \times (\sqrt[4]{81})^{-3}}$$

(l)
$$\frac{32^{\frac{2}{5}} \times 81^{-\frac{3}{4}} \times 25^{\frac{4}{3}}}{(8^2)^{-1} \times (9^{1/3})^{-3} \times (5^{3/2})^{-4}}$$

Worked example 1.7.1

Calculate:

$$\frac{\sqrt{2\frac{1}{4}} \times \left(\frac{1}{27}\right)^{\frac{2}{3}}}{\sqrt[3]{15\frac{5}{8}} \times \left(\frac{1}{32}\right)^{-\frac{2}{5}}} =$$

We start by turning mixed fractions into proper fractions and change every number into a power of 2, 3 or 5. We also use the law of negative exponents:

$$= \frac{\sqrt{\frac{3^2}{2^2}} \times (3^{-3})^{\frac{2}{3}}}{\sqrt[3]{\frac{5^3}{2^3}} \times (2^{-5})^{-\frac{2}{5}}}$$

Now we can apply the power of a power law and power of a quotient law to simplify our expression:

$$= \frac{\frac{3}{2} \times 3^{-2}}{\frac{5}{2} \times 2^2} =$$

This gives:

$$= \frac{\frac{3}{2} \times \frac{1}{9}}{\frac{5}{2} \times 4} = \frac{1}{60}$$

Exercise 1.7.1

Calculate:

$$(a) \frac{\sqrt{1\frac{7}{9}} \times \left(\frac{1}{8}\right)^{-\frac{1}{3}}}{\sqrt[4]{5\frac{1}{16}} \times \left(\frac{1}{81}\right)^{-\frac{3}{4}}}$$

$$(b) \frac{\sqrt{1\frac{9}{16}} \times \sqrt[4]{16}}{\left(\frac{1}{\sqrt{2}}\right)^6 \times (\sqrt{3})^{-4}}$$

$$(c) \frac{\sqrt{1\frac{11}{25}} \times \left(\frac{1}{4}\right)^{-\frac{1}{2}}}{\left(\sqrt[3]{\frac{2}{3}}\right)^6 \times \left(2\frac{7}{9}\right)^{-\frac{1}{2}}}$$

$$(d) \frac{\sqrt{1\frac{24}{25}} \times \left(\frac{1}{25}\right)^{-\frac{1}{2}}}{\left(\sqrt[4]{\frac{1}{4}}\right)^6 \times \left(\frac{1}{7}\right)^{-2}}$$

$$(e) \frac{\sqrt{5^4} \times \left(\frac{1}{\sqrt{27}}\right)^{-\frac{2}{3}}}{\sqrt[3]{3\frac{3}{8}} \times \left(\frac{1}{\sqrt[3]{9}}\right)^{-\frac{3}{2}}}$$

$$(f) \frac{\sqrt[3]{3^6} \times \left(\frac{9}{25}\right)^{-\frac{3}{2}}}{\left(\sqrt[4]{5}\right)^8 \times \left(\frac{9}{64}\right)^{-\frac{1}{2}}}$$

Worked example 1.7.2

Write

$$\frac{8^5 \times \left(\frac{1}{4}\right)^3}{16^{-2} \times 32^4}$$

as a power of 2.

We start by expressing every number as a power of 2:

$$\frac{(2^3)^5 \times (2^{-2})^3}{(2^4)^{-2} \times (2^5)^4} =$$

We now apply the power of a power law:

$$= \frac{2^{15} \times 2^{-6}}{2^{-8} \times 2^{20}} =$$

Now the product of powers law:

$$= \frac{2^9}{2^{12}} =$$

And finally the quotient of powers law:

$$= 2^{-3}$$

Exercise 1.7.2

Write the following as a power of 2:

(a) $\frac{32^3 \times \left(\frac{1}{8}\right)^2}{8^{-4} \times 4^4}$

(b) $\frac{16^3 \times \left(\frac{1}{8}\right)^2}{64^{-1} \times 16^{\frac{1}{2}}}$

(c) $\frac{4^5 \times \left(\frac{1}{16}\right)^3}{32^{-2} \times 4^{\frac{2}{3}}}$

Write the following as a power of 3:

(d) $\frac{9^4 \times \left(\frac{1}{27}\right)^2}{81^{-1} \times 9^{\frac{1}{2}}}$

(e) $\frac{27^3 \times \left(\frac{1}{9}\right)^2}{243^{-2} \times 27^{\frac{1}{4}}}$

(f) $\frac{81^2 \times \left(\frac{1}{243}\right)^3}{729^{-1} \times 81^{\frac{1}{3}}}$

Write the following as a power of 5:

(g) $\frac{25^2 \times \left(\frac{1}{125}\right)^3}{625^{-1} \times 25^{\frac{1}{4}}}$

(h) $\frac{125^3 \times \left(\frac{1}{25}\right)^2}{3125^{-2} \times 125^{\frac{1}{2}}}$

(i) $\frac{625^4 \times \left(\frac{1}{5}\right)^3}{(0.2)^{-3} \times 625^{\frac{1}{3}}}$

Write the following as a power of x :

(j) $\frac{x^4 \times \left(\frac{1}{x^2}\right)^3}{x^{-2} \times x^{\frac{1}{2}}}$

(k) $\frac{x^5 \times \left(\frac{1}{x^3}\right)^2}{x^{-4} \times x^{\frac{2}{3}}}$

(l) $\frac{x^6 \times \left(\frac{1}{x^4}\right)^2}{x^{-3} \times x^{\frac{3}{4}}}$

Worked example 1.7.3**Simplify:**

$$\frac{(16(\frac{a}{b^3})^3 b^2)^{-2} \times (8ab^2)^{-1}}{(4a^{-3}b^2)^5}$$

We start by expressing numbers as a power of 2 and we apply the power of product law and power of a power law:

$$\frac{(2^{-8}(\frac{a}{b^3})^{-6}b^{-4}) \times (2^{-3}a^{-1}b^{-2})}{2^{10}a^{-15}b^{10}} =$$

We now apply the product and quotient of power laws:

$$= \frac{2^{-11}a^{-7}b^{12}}{2^{10}a^{-15}b^{10}} =$$

And finally the quotient of powers one more time:

$$= 2^{-21}a^8b^2$$

Exercise 1.7.3

Simplify the following expressions:

$$(a) \frac{(2a^3b^{-2})^3 \times (4a^{-2}b^5)^{-2}}{(16a^{-4}b)^2}$$

$$(b) \frac{(3x^{-2}y^5)^2 \times (27x^3y^{-4})^{-3}}{(x^2y^{-3})^4}$$

$$(c) \frac{(5a^3b^{-1})^2 \times (a^{-2}b^4)^{-3}}{(25a^2b^{-3})^2}$$

$$(d) \frac{(x^2y^{-3}z)^2 \times (3x^{-1}y^4z^{-2})^{-2}}{(9x^3y^{-2}z^{-1})^2}$$

$$(e) \frac{(2(\frac{a}{b})^5 b^{-3})^4 \times (4(\frac{b^2}{a})^{-3} b^2)^{-1}}{(16a^2b^{-3})^2}$$

$$(f) \frac{((\frac{x^2}{y^3})^{-2} z^3)^4 \times (9x^{-1}(\frac{y^2}{z})^{-3})^{-2}}{(27x^2y^{-1}z^{-3})^4}$$

$$(g) \frac{(2(\frac{a}{b})^3 b^5)^2 \times (3(\frac{b^2}{a})^2 a^4)^{-2}}{(12a^2b^{-3})^3}$$

$$(h) \frac{(4(\frac{x}{y})^2 y^4)^3 \times (5(\frac{y^3}{x})^{-1} x^3)^{-1}}{(20x^2y^{-2})^2}$$

$$(i) \frac{(3(\frac{c}{d})^6 d^4)^3 \times (6(\frac{d^2}{c})^{-2} c^3)^{-1}}{(36c^2d^{-3})^2}$$

$$(j) \frac{\left(\left(\frac{p^3}{q^2}\right)^4 r^2\right)^2 \times \left(\frac{8r^3}{p(\frac{q^2}{r})^{-1}}\right)^{-3}}{(64pq^{-2}r^3)^3}$$

Worked example 1.7.4

Give an example of a natural number raised to a rational power which is:

- (a) a natural number,
 (b) a rational number which isn't an integer,
 (c) an irrational number.

(a) $5^2 = 25$ and 5 is a natural number, 2 is rational and 25 is a natural number. A less trivial example is

$$8^{\frac{2}{3}} = (\sqrt[3]{8})^2 = 4$$

8 and 4 are both natural numbers and $\frac{2}{3}$ is rational.

(b)

$$4^{-\frac{1}{2}} = \frac{1}{\sqrt{4}} = \frac{1}{2}$$

4 is a natural number and both $\frac{1}{2}$ and $-\frac{1}{2}$ are rational.

(c)

$$2^{\frac{1}{2}} = \sqrt{2}$$

2 is a natural number, $\frac{1}{2}$ is rational and $\sqrt{2}$ is irrational.

Exercise 1.7.4

For the following statements decide, if they're true or false. Justify your answers.

- (a) A natural number raised to a natural power is always a natural number.
 (b) An integer raised to an integer power is always an integer.
 (c) A rational number raised to a rational power is always rational.
 (d) A rational number raised to a rational power is always irrational.
 (e)* An irrational number raised to an irrational power is always irrational.

We define irrational powers as limits of rational powers. We have

$$\sqrt{2} \approx 1.41421356237$$

and we define $3^{\sqrt{2}}$ as the limit of the following sequence of numbers:

$$3^1, 3^{1.4}, 3^{1.41}, 3^{1.414}, 3^{1.4142}, \dots$$

Of course every term of this sequence can be evaluated by using the law of fractional exponents. For example:

$$3^{1.4142} = 3^{\frac{14142}{10000}} = \sqrt[10000]{3^{14142}} \approx 4.72873393017$$

If we put $3^{\sqrt{2}}$ into a calculator, we get:

$$3^{\sqrt{2}} \approx 4.72880438784$$

Comparing numbers

1. By writing each of the following numbers as a power of 2, list them in an ascending order:

$$4^{50}, \quad 8^{27}, \quad 128^{16}, \quad 1024^8, \quad (\sqrt{2})^{120}, \quad \left(\frac{1}{2}\right)^{-95}$$

2. By writing each of the following numbers as powers of different numbers with exponents equal to 16, list them in an ascending order:

$$25^8, \quad 2^{64}, \quad 3^8, \quad 4^{48}, \quad 7^{16}, \quad 6^{32}$$

Now we would like to arrange in an ascending order the following numbers:

$$222^{555}, \quad 333^{444}, \quad 444^{333}, \quad 555^{222}$$

3. Write each of the above numbers as powers of different numbers with exponent equal to 111 (the highest common factor of 555, 444, 333, 222). You may want to use the power rule.

4. Now we need to compare the following numbers:

$$222^5, \quad 333^4, \quad 444^3, \quad 555^2$$

Find the highest common factor of all these numbers.

5. Now we need to compare the following numbers:

$$2^5 \times 111^3, \quad 3^4 \times 111^2, \quad 4^3 \times 111, \quad 5^2$$

The above numbers are very easy to compare.

6. Use similar approach to compare:

$$777^{999}, \quad 888^{888}, \quad 999^{777}$$

The following examples show how to use you GDC for calculations required in this section.

EXAMPLE 1

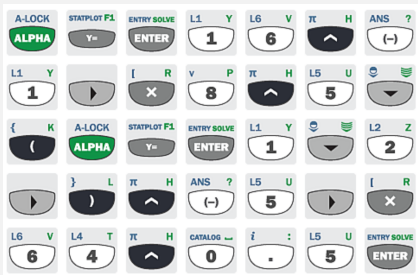
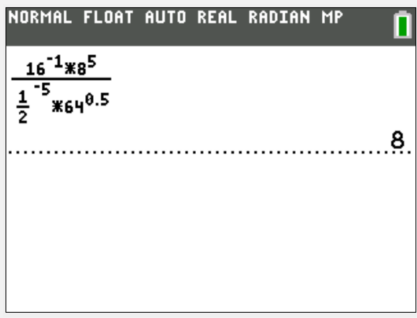
<p>Calculate:</p> $\frac{16^{-1} \times 8^5}{\left(\frac{1}{2}\right)^{-5} \times 64^{0.5}}$	<p>INPUT</p> 	<p>OUTPUT</p> 
---	---	---

Beware that on Ti-84 there is a distinction between negative sign and subtraction sign.

EXAMPLE 2

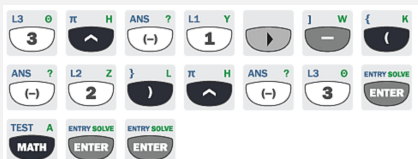
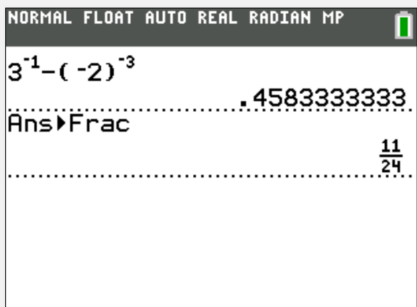
<p>Calculate:</p> $3^{-1} - (-2)^{-3}$	<p>INPUT</p> 	<p>OUTPUT</p> 
---	---	---

SHORT TEST

1. Evaluate: [2 points]

(a) $27^{\frac{2}{3}}$

(b) $16^{-\frac{3}{4}}$

2. Write as a power of 3: [4 points]

(a) $\frac{(\sqrt{3})^4 \times 27^{-2}}{(\frac{1}{9})^{\frac{1}{2}} \times 81^2}$

(b) $\frac{(\sqrt{3})^3 \times 9^{-2}}{(\frac{1}{3})^{\frac{3}{4}} \times 27^{\frac{1}{2}}}$

3. Simplify: [4 points]

(a) $\frac{(a^2b)^3 \times (2a)^{-2}}{(\frac{a}{b^2})^{-3} \times (4b^2)^{-2}}$

(b) $\frac{(c^3d^2)^4 \times (27c)^{-2}}{(\frac{c^3}{d^2})^{-1} \times (9d^2)^{-3}}$

4. Give an example of: [2 points]

(a) an integer raised to a natural power which gives a negative integer,

(b) a negative integer raised to a rational power which gives a negative rational number which isn't an integer.

**SHORT TEST
SOLUTIONS**

1. Evaluate: [2 points]

$$(a) 27^{\frac{2}{3}} = (\sqrt[3]{27})^2 = 3^2 = 9$$

$$(b) 16^{-\frac{3}{4}} = \frac{1}{(\sqrt[4]{16})^3} = \frac{1}{2^3} = \frac{1}{8}$$

2. Write as a power of 3: [4 points]

$$(a) \frac{(\sqrt{3})^4 \times 27^{-2}}{\left(\frac{1}{9}\right)^{\frac{1}{2}} \times 81^2}$$

$$= \frac{3^2 \times 3^{-6}}{3^{-1} \times 3^8} =$$

$$= \frac{3^{-4}}{3^7} = 3^{-11}$$

$$(b) \frac{(\sqrt{3})^3 \times 9^{-2}}{\left(\frac{1}{3}\right)^{\frac{3}{4}} \times 27^{\frac{1}{2}}}$$

$$= \frac{3^{\frac{3}{2}} \times 3^{-4}}{3^{-\frac{3}{4}} \times 3^{\frac{3}{2}}} =$$

$$= \frac{3^{-4}}{3^{-\frac{3}{4}}} = 3^{-3\frac{1}{4}}$$

3. Simplify: [4 points]

$$(a) \frac{(a^2b)^3 \times (2a)^{-2}}{\left(\frac{a}{b^2}\right)^{-3} \times (4b^2)^{-2}}$$

$$= \frac{2^{-2}a^4b^3}{2^{-4}a^{-3}b^2} = 2^2a^7b$$

$$(b) \frac{(c^3d^2)^4 \times (27c)^{-2}}{\left(\frac{c^3}{d^2}\right)^{-1} \times (9d^2)^{-3}}$$

$$= \frac{3^{-6}c^{10}d^8}{3^{-6}c^{-3}d^{-4}} = c^{13}d^{12}$$

4. Give an example of: [2 points]

(a) an integer raised to a natural power which gives a negative integer,

$$(-2)^3 = -8$$

(b) a negative integer raised to a rational power which gives a negative rational number which isn't an integer.

$$(-8)^{-\frac{1}{3}} = \frac{1}{\sqrt[3]{-8}} = -\frac{1}{2}$$

1.8 Standard form

A number is written in the standard form if it is in the form:

$$a \times 10^k$$

where a is a real number with $1 \leq a < 10$ and k is an integer. The following numbers are all in standard form:

$$3.54 \times 10^5, \quad 1.001 \times 10^{-100}, \quad 9.9241 \times 10^{13}, \quad 5 \times 10^1, \quad 3.14 \times 10^0$$

The following numbers are **not** in standard form:

$$37, \quad 0.52 \times 10^5, \quad 123.4 \times 10^{41}, \quad 0.00554 \times 10^{-33}, \quad 0.0000022$$

They can however be easily written in standard form as follows:

$$3.7 \times 10^1, \quad 5.2 \times 10^4, \quad 1.234 \times 10^{43}, \quad 5.54 \times 10^{-36}, \quad 2.2 \times 10^{-6}$$

Worked example 1.8.1

Write the following numbers in standard form:

(a) 52451.2

(b) 0.001357

(a) We need to move the decimal point 4 places to the left so:

$$52451.2 = 5.24512 \times 10^4$$

(b) We need to move the decimal point 3 places to the right so:

$$0.001357 = 1.357 \times 10^{-3}$$

Exercise 1.8.1

Write the following in standard form:

(a) 12000

(b) 0.095

(c) 3500000

(d) 530×10^4

(e) 0.00324×10^{-4}

(f) 251×10^{-11}

(g) $\frac{53}{1000}$

(h) $\frac{1}{2000}$

(i) $\frac{31}{20000000}$

Worked example 1.8.2

Calculate the following, give your answer in standard form:

$$(a) \frac{(6.51 \times 10^4) \times (8.22 \times 10^{-6})}{2.77 \times 10^{-7}}$$

$$(b) (3.11 \times 10^8) + (7.51 \times 10^7) - (2.05 \times 10^6)$$

(a) We will deal with powers of ten separately:

$$\frac{6.51 \times 8.22}{2.77} \times \frac{10^4 \times 10^{-6}}{10^{-7}}$$

Now we can calculate the first fraction on a calculator and the second using index laws. Finally we need to make sure that the answer is in the standard form.

$$\approx 19.3 \times 10^5 = 1.93 \times 10^6$$

(b) We first make sure that we have the same power of 10 in each term:

$$(311 \times 10^6) + (75.1 \times 10^6) - (2.05 \times 10^6)$$

Now we can add and subtract the terms and finally turn the answer back into standard form:

$$= 384.05 \times 10^6 = 3.8405 \times 10^8$$

Exercise 1.8.2

Calculate the following. Give your answer in the standard form:

$$(a) \frac{(4.57 \times 10^{11}) \times (5.21 \times 10^4)}{3.91 \times 10^5}$$

$$(b) \frac{2.11 \times 10^6}{(3.17 \times 10^{-3}) \times (9.25 \times 10^3)}$$

$$(c) \frac{(6.71 \times 10^{-4}) \times (1.01 \times 10^{-3})}{(5.23 \times 10^{-7}) \times (8.14 \times 10^2)}$$

$$(d) \frac{(2.51 \times 10^{14}) \times (3.12 \times 10^{18})}{(2.35 \times 10^7) \times (1.48 \times 10^{12})}$$

$$(e) (6.12 \times 10^5) + (5.41 \times 10^6)$$

$$(f) (7.82 \times 10^{-8}) + (9.15 \times 10^{-9})$$

$$(g) (8.32 \times 10^9) - (6.61 \times 10^8)$$

$$(h) (3.23 \times 10^{-11}) - (8.54 \times 10^{-12})$$

(i)
$$\frac{(1.32 \times 10^{10}) + (4.11 \times 10^{11})}{9.21 \times 10^5}$$

(j)
$$\frac{3.18 \times 10^{-5}}{(5.27 \times 10^{-6}) + (7.35 \times 10^{-7})}$$

(k)
$$\frac{(5.52 \times 10^{-3}) - (2.13 \times 10^{-4})}{(1.58 \times 10^3)^2}$$

(l)
$$\frac{(7.88 \times 10^{-2})^3}{(9.21 \times 10^6) - (8.11 \times 10^4)}$$

(k)
$$\frac{(1.32 \times 10^5) + (2.63 \times 10^2)^2}{(6.56 \times 10^{-3}) + (6.16 \times 10^{-2})^2}$$

(l)
$$\frac{(5.58 \times 10^{10})^2 + (3.79 \times 10^{20})}{(9.96 \times 10^{11}) + (4.01 \times 10^9)}$$

Exercise 1.8.3

Calculate the area and perimeter of a rectangle with side-lengths x and y . Express your answer in standard form.

(a) $x = 3.2 \times 10^3 \text{ cm}$ and $y = 1.6 \times 10^4 \text{ cm}$

(b) $x = 5.33 \times 10^{-4} \text{ m}$ and $y = 2.29 \times 10^{-5} \text{ m}$

(c) $x = 5.06 \times 10^4 \text{ m}$ and $y = 9.76 \times 10^4 \text{ cm}$

(d) $x = 2.38 \times 10^{-4} \text{ cm}$ and $y = 9.25 \times 10^{-4} \text{ cm}$

(e) $x = 2.5 \times 10^2 \text{ km}$ and $y = 7.6 \times 10^4 \text{ m}$

(f) $x = 7.83 \times 10^{-3} \text{ dm}$ and $y = 7.79 \times 10^{-5} \text{ m}$

Exercise 1.8.4*

Find the perimeter of a square whose area is A . Give your answer in standard form.

(a) $A = 1.44 \times 10^4 \text{ m}^2$

(b) $A = 2.56 \times 10^{-6} \text{ cm}^2$

(c) $A = 5.56 \times 10^7 \text{ dm}^2$

(d) $A = 3.86 \times 10^{-5} \text{ m}^2$

(e) $A = 8.13 \times 10^{11} \text{ cm}^2$

(f) $A = 9.89 \times 10^{-31} \text{ m}^2$

Orders of magnitude

An order of magnitude of a certain value is the smallest power of ten needed to represent that value. One can use the standard form as the representation in which case the order of magnitude is the exponent of 10 in the standard form.

1. Write the orders of magnitude of the following numbers:

21, 1440, 0.000031, 2700000, 0.013, 2999999999

2. By how many orders of magnitude is 1500 greater than 0.000232?
3. By how many orders of magnitude is the distance from Earth to Proxima Centauri greater than the Planck length?

Distance from Earth to Proxima Centauri $\approx 4.017 \times 10^{16}$ metres.

Planck length $\approx 1.616 \times 10^{-35}$ metres.

4. By how many orders of magnitude is the mass of the Earth greater than Planck mass?

Earth's mass $\approx 5.927 \times 10^{27}$ grams.

Planck mass $\approx 2.176 \times 10^{-5}$ grams.

The prefix pecto- represents 10^{-12} , nano- represents 10^{-9} and the following increase by 3 orders of magnitude: micro-, milli-, kilo-, mega-, giga-, tera-. Where tera- represents 10^{12} .

5. By how many orders of magnitude is 1 kilometre greater than 1 nanometre?
6. By how many orders of magnitude is 1 milligram smaller than 1 teragram?

The following examples show how to use you GDC for calculations required in this section. On your GCD the standard form (or scientific notation) is represented with the symbol *E*. For example 3.7×10^7 will be written as $3.7E10$

EXAMPLE 1

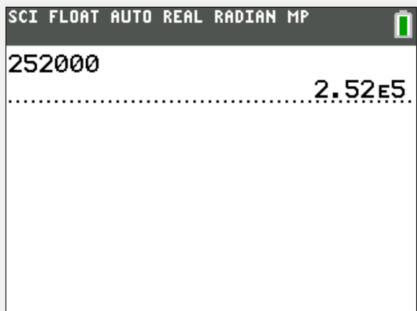
<p>Write 252000 in standard form.</p>	<p>INPUT</p> 	<p>OUTPUT</p> 
---------------------------------------	---	---

EXAMPLE 2

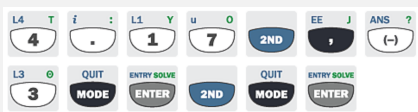
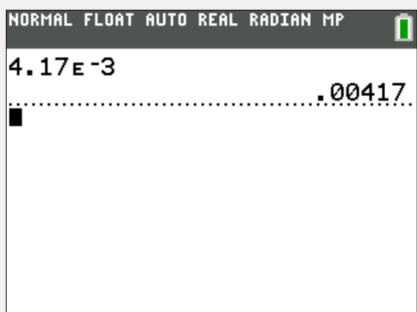
<p>Write 4.17×10^{-3} as a decimal</p>	<p>INPUT</p> 	<p>OUTPUT</p> 
--	--	--

Note that for higher powers of 10 (both positive and negative) the Ti-84 will display the answer using standard form.

EXAMPLE 3

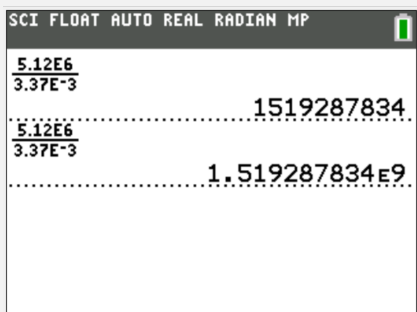
<p>Calculate:</p> $\frac{5.12 \times 10^6}{3.37 \times 10^{-3}}$	<p>INPUT</p> 	<p>OUTPUT</p> 
--	---	---

SHORT TEST

1. [2 points]

Write down the following numbers in the standard form:

(a) 320000

(b) 0.0000522

(c) 257×10^{13}

(d) $\frac{13}{4000000}$

2. [3 points]

Arrange the following numbers in ascending order:

$$3.15 \times 10^5, \quad 5.63 \times 10^{-2}, \quad 9.21 \times 10^{-2}, \quad 0.0832, \quad 223 \times 10^3, \quad 0.000042 \times 10^3$$

3. [4 points]

Calculate, giving your answer in standard form:

(a) $\frac{(8.32 \times 10^7) - (1.53 \times 10^3)^2}{(3.54 \times 10^{-4}) + (6.16 \times 10^{-6})}$

(1) $\frac{(1.58 \times 10^8) \times (5.75 \times 10^{-3})}{(8.16 \times 10^6) + (4.33 \times 10^2)^3}$

4. [3 points]

Calculate the area and perimeter of a rectangle with side-lengths of $5.32 \times 10^3 \text{ m}$ and $9.21 \times 10^4 \text{ cm}$.
Give your answers in standard form.

**SHORT TEST
SOLUTIONS**

- 1.** [2 points]
Write down the following numbers in the standard form:

(a) 320000 (b) 0.0000522 (c) 257×10^{13} (d) $\frac{13}{4000000}$

(a) 3.2×10^5 (b) 5.22×10^{-5} (c) 2.57×10^{15} (d) 3.25×10^{-6}

- 2.** [3 points]
Arrange the following numbers in ascending order:

3.15×10^5 , 5.63×10^{-2} , 9.21×10^{-2} , 0.0832, 223×10^3 , 0.000042×10^3

0.000042×10^3 , 5.63×10^{-2} , 0.0832, 9.21×10^{-2} , 223×10^3 , 3.15×10^5

- 3.** [4 points]
Calculate, giving your answer in standard form:

(a) $\frac{(8.32 \times 10^7) - (1.53 \times 10^3)^2}{(3.54 \times 10^{-4}) + (6.16 \times 10^{-6})}$ (1) $\frac{(1.58 \times 10^8) \times (5.75 \times 10^{-3})}{(8.16 \times 10^6) + (4.33 \times 10^2)^3}$

$= \frac{(83.2 \times 10^6) - (2.3409 \times 10^6)}{(354 \times 10^{-6}) + (6.16 \times 10^{-6})} =$ $= \frac{9.085 \times 10^5}{(8.16 \times 10^6) + (81.1827 \times 10^6)} =$

$= \frac{80.8591 \times 10^6}{360.16 \times 10^{-6}} =$ $= \frac{9.085 \times 10^5}{89.3427 \times 10^6} =$

$\approx 0.225 \times 10^{12} = 2.25 \times 10^{11}$ $\approx 0.102 \times 10^{-1} = 1.02 \times 10^{-2}$

- 4.** [3 points]
Calculate the area and perimeter of a rectangle with side-lengths of $5.32 \times 10^3 \text{ m}$ and $9.21 \times 10^4 \text{ cm}$. Give your answers in standard form.

$9.21 \times 10^4 \text{ cm} = 9.21 \times 10^2 \text{ m}$

Area = $(5.32 \times 10^3 \text{ m}) \times (9.21 \times 10^2 \text{ m}) \approx 49.5 \times 10^5 \text{ m}^2 = 4.95 \times 10^6 \text{ m}^2$

Perimeter = $(2 \times 5.32 \times 10^3 \text{ m}) + (2 \times 9.21 \times 10^2 \text{ m}) = (10.64 \times 10^3 \text{ m}) + (18.42 \times 10^2 \text{ m}) =$
 $= 12.482 \times 10^3 \text{ m} = 1.2482 \times 10^4 \text{ m}$

1.9 Surds

For non-negative numbers a and b and positive integers m and n we have:

$$1. \sqrt[n]{a \times b} = \sqrt[n]{a} \times \sqrt[n]{b}$$

$$\text{Example: } \sqrt[3]{54} = \sqrt[3]{27 \times 2} = \sqrt[3]{27} \times \sqrt[3]{2} = 3\sqrt[3]{2}.$$

$$2. \sqrt[n]{\frac{a}{b}} = \frac{\sqrt[n]{a}}{\sqrt[n]{b}} \text{ for } b \neq 0$$

$$\text{Example: } \sqrt{1.25} = \sqrt{\frac{5}{4}} = \frac{\sqrt{5}}{\sqrt{4}} = \frac{\sqrt{5}}{2}.$$

$$3. \sqrt[n]{a^m} = (\sqrt[n]{a})^m$$

$$\text{Example: } \sqrt[5]{32^3} = (\sqrt[5]{32})^3 = 2^3 = 8.$$

Worked example 1.9.1

Write

$$4\sqrt{32} + 3\sqrt{50} - 2\sqrt{98}$$

in the form $a\sqrt{2}$, where $a \in \mathbb{Z}$.

We start by writing the expressions under the $\sqrt{\quad}$ sign as a multiple of a square number. In this example it is always a square number times 2:

$$4\sqrt{16 \times 2} + 3\sqrt{25 \times 2} - 2\sqrt{49 \times 2} =$$

Now we use the properties of surds to get:

$$= 4\sqrt{16} \times \sqrt{2} + 3\sqrt{25} \times \sqrt{2} - 2\sqrt{49} \times \sqrt{2} =$$

Which gives:

$$= 16\sqrt{2} + 15\sqrt{2} - 14\sqrt{2} =$$

Now we can perform the addition and subtraction to get:

$$= 17\sqrt{2}$$

Exercise 1.9.1aWrite in the form $a\sqrt{2}$, where $a \in \mathbb{Z}$:

(a) $4\sqrt{32} + 3\sqrt{50} - 2\sqrt{98}$

(b) $6\sqrt{18} - 4\sqrt{72} + 5\sqrt{32}$

(c) $7\sqrt{8} + 3\sqrt{72} - 2\sqrt{50}$

Write in the form $a\sqrt{3}$, where $a \in \mathbb{Z}$:

(d) $5\sqrt{27} + 2\sqrt{75} - 3\sqrt{48}$

(e) $6\sqrt{12} - 4\sqrt{75} + \sqrt{108}$

(f) $4\sqrt{27} - 2\sqrt{147} + 8\sqrt{75}$

Write in the form $a\sqrt{5}$, where $a \in \mathbb{Z}$:

(g) $3\sqrt{45} + 2\sqrt{125} - 4\sqrt{20}$

(h) $7\sqrt{80} - 5\sqrt{45} + 3\sqrt{125}$

(i) $6\sqrt{45} - 2\sqrt{210} + \sqrt{125}$

Write in the form $a\sqrt{7}$, where $a \in \mathbb{Z}$:

(j) $4\sqrt{28} - 3\sqrt{63} + \sqrt{700}$

(k) $\sqrt{343} - 2\sqrt{112} + 2\sqrt{175}$

(l) $4\sqrt{175} - 2\sqrt{252} + \sqrt{28}$

Exercise 1.9.1bWrite in the form $a\sqrt[3]{2}$, where $a \in \mathbb{Z}$:

(a) $3\sqrt[3]{16} + 2\sqrt[3]{54} - 2\sqrt[3]{128}$

(b) $3\sqrt[3]{250} - 5\sqrt[3]{16} + \sqrt[3]{432}$

(c) $3\sqrt[3]{128} - 3\sqrt[3]{250} - 2\sqrt[3]{2000}$

Write in the form $a\sqrt[3]{3}$, where $a \in \mathbb{Z}$:

(d) $\sqrt[3]{81} + 2\sqrt[3]{24} - 2\sqrt[3]{192}$

(e) $3\sqrt[3]{375} - 5\sqrt[3]{81} + \sqrt[3]{192}$

(f) $5\sqrt[3]{3000} - 3\sqrt[3]{375} - \sqrt[3]{648}$

Write in the form $a\sqrt[3]{5}$, where $a \in \mathbb{Z}$:

(g) $5\sqrt[3]{40} + 4\sqrt[3]{135} - 3\sqrt[3]{320}$

(h) $3\sqrt[3]{625} - \sqrt[3]{1080} + 5\sqrt[3]{40}$

(i) $8\sqrt[3]{135} - \sqrt[3]{5000} + 2\sqrt[3]{320}$

When a surd appears in the denominator you may be required to rationalize it (turn it into a rational number). This can be achieved by multiplying the given fraction by 1 (and hence not changing the value of the fraction) expressed in a suitable way.

Worked example 1.9.2

Rationalize the denominator in the following fractions:

(a) $\frac{10}{\sqrt{2}}$

(b) $\frac{6}{\sqrt[3]{3}}$

(c) $\frac{5}{2 + \sqrt{3}}$

(d) $\frac{8}{3 - \sqrt{5}}$

(a) We multiply the fraction by $\frac{\sqrt{2}}{\sqrt{2}}$ in order to have a square number under the square root in the denominator:

$$\frac{10}{\sqrt{2}} \times \frac{\sqrt{2}}{\sqrt{2}} = \frac{10\sqrt{2}}{\sqrt{4}} = \frac{10\sqrt{2}}{2} = 5\sqrt{2}$$

(b) We multiply the fraction by $\frac{\sqrt[3]{9}}{\sqrt[3]{9}}$ in order to have a cube number under the cube root in the denominator:

$$\frac{6}{\sqrt[3]{3}} \times \frac{\sqrt[3]{9}}{\sqrt[3]{9}} = \frac{6\sqrt[3]{9}}{\sqrt[3]{27}} = \frac{6\sqrt[3]{9}}{3} = 2\sqrt[3]{9}$$

(c) We multiply the fraction by $\frac{2 - \sqrt{3}}{2 - \sqrt{3}}$. Note that the expression in the denominator becomes:

$$(2 + \sqrt{3})(2 - \sqrt{3}) = 4 - 2\sqrt{3} + 2\sqrt{3} - \sqrt{9} = 4 - 3 = 1$$

$$\frac{5}{2 + \sqrt{3}} \times \frac{2 - \sqrt{3}}{2 - \sqrt{3}} = \frac{10 - 5\sqrt{3}}{1} = 10 - 5\sqrt{3}$$

(d) We multiply the fraction by $\frac{3 + \sqrt{5}}{3 + \sqrt{5}}$. Note that the expression in the denominator becomes:

$$(3 - \sqrt{5})(3 + \sqrt{5}) = 9 + 3\sqrt{5} - 3\sqrt{5} - \sqrt{25} = 9 - 5 = 4$$

$$\frac{8}{3 - \sqrt{5}} \times \frac{3 + \sqrt{5}}{3 + \sqrt{5}} = \frac{8 \times (3 + \sqrt{5})}{4} = 6 + 2\sqrt{5}$$

Exercise 1.9.2

Rationalize the denominator in the following fractions:

(a) $\frac{10}{\sqrt{2}}$

(b) $\frac{15}{\sqrt{5}}$

(c) $\frac{12}{\sqrt{6}}$

(d) $\frac{21}{\sqrt{7}}$

(e) $\frac{3}{2\sqrt{2}}$

(f) $\frac{12}{5\sqrt{3}}$

(g) $\frac{7}{2\sqrt{5}}$

(h) $\frac{20}{3\sqrt{10}}$

(i) $\frac{4}{\sqrt[3]{2}}$

(j) $\frac{10}{\sqrt[3]{25}}$

(k) $\frac{3}{\sqrt[3]{9}}$

(l) $\frac{8}{\sqrt[3]{36}}$

(m) $\frac{6}{3 + \sqrt{3}}$

(n) $\frac{8}{2 + \sqrt{2}}$

(o) $\frac{10}{5 + \sqrt{5}}$

(p) $\frac{8}{\sqrt{6} + 2}$

(q) $\frac{26}{4 - \sqrt{3}}$

(r) $\frac{7}{5 - \sqrt{6}}$

(s) $\frac{10}{7 - \sqrt{3}}$

(t) $\frac{5}{\sqrt{6} - 1}$

(u) $\frac{2}{3\sqrt{3} - 5}$

(v) $\frac{8}{4 - 3\sqrt{2}}$

(w) $\frac{20}{7 - 4\sqrt{3}}$

(x) $\frac{7}{2\sqrt{5} + 1}$

(y) $\frac{2}{\sqrt{3} + \sqrt{2}}$

(z) $\frac{1}{\sqrt{3} - \sqrt{6}}$

(zz) $\frac{7}{\sqrt{5} + \sqrt{3}}$

(zzz) $\frac{12}{\sqrt{7} - \sqrt{3}}$

Roots of negative numbers

1. Use the property:

$$\sqrt{a \times b} = \sqrt{a} \times \sqrt{b}$$

to simplify $\sqrt{12}$, $\sqrt{20}$, $\sqrt{50}$, $\sqrt{108}$

2. Write down the value of $\sqrt{16}$, $\sqrt{49}$, $\sqrt{225}$, $\sqrt{1024}$

3. Write down the value of $\sqrt{2} \times \sqrt{2}$, $\sqrt{5} \times \sqrt{5}$, $\sqrt{8} \times \sqrt{8}$, $\sqrt{11} \times \sqrt{11}$

4. Use the part (3) to suggest the value of $\sqrt{-3} \times \sqrt{-3}$, $\sqrt{-6} \times \sqrt{-6}$, $\sqrt{-10} \times \sqrt{-10}$, $\sqrt{-13} \times \sqrt{-13}$

5. Repeat part (4) but this time use the property from (1) assuming that it also works for negative numbers.

6. Compare the answers from parts (4) and (5).

7. What does it say about the property:

$$\sqrt{a \times b} = \sqrt{a} \times \sqrt{b}$$

8. Do we have the same problem for $\sqrt[3]{}$, $\sqrt[4]{}$, $\sqrt[5]{}$, ...

9. Generalize your investigation for the property:

$$\sqrt[n]{a \times b} = \sqrt[n]{a} \times \sqrt[n]{b}$$

Ti-84 does not give answers in surd form, only in decimal. You can however use the GDC to check your answers.

EXAMPLE 1

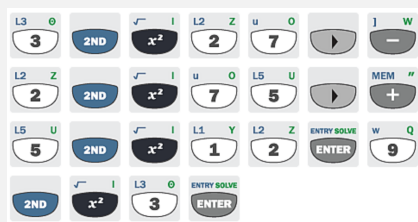
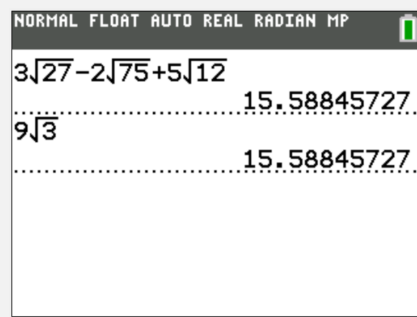
<p>Write in the form $a\sqrt{3}$:</p> $3\sqrt{27} - 2\sqrt{75} + 5\sqrt{12}$	<p>INPUT</p> 	<p>OUTPUT</p> 
---	---	---

EXAMPLE 2

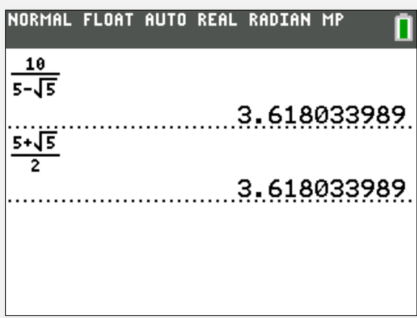
<p>Rationalize the denominator of:</p> $\frac{10}{5 - \sqrt{5}}$	<p>INPUT</p> 	<p>OUTPUT</p> 
--	--	--

SHORT TEST

1. [2 points]

Write in the form $a\sqrt{2}$ or $a\sqrt{3}$, where $a \in \mathbb{Z}$:

(a) $5\sqrt{8} - 3\sqrt{50} + 2\sqrt{72}$

(b) $7\sqrt{12} - 5\sqrt{27} + 6\sqrt{75}$

2. [2 points]

Write in the form $a\sqrt[3]{2}$ or $a\sqrt[3]{3}$, where $a \in \mathbb{Z}$:

(a) $2\sqrt[3]{16} - 4\sqrt[3]{54} + 5\sqrt[3]{128}$

(b) $\sqrt[3]{24} - 2\sqrt[3]{81} + 2\sqrt[3]{375}$

3. [3 points]

Rationalize the following fractions:

(a) $\frac{12}{\sqrt{3}}$

(b) $\frac{15}{2\sqrt{5}}$

(c) $\frac{2}{\sqrt[3]{4}}$

4. [3 points]

Rationalize the following fractions:

(a) $\frac{2}{3 - \sqrt{3}}$

(b) $\frac{8}{4 + \sqrt{2}}$

(c) $\frac{11}{3 - 2\sqrt{2}}$

**SHORT TEST
SOLUTIONS**

1.

[2 points]

Write in the form $a\sqrt{2}$ or $a\sqrt{3}$, where $a \in \mathbb{Z}$:

(a) $5\sqrt{8} - 3\sqrt{50} + 2\sqrt{72} =$

$= 5\sqrt{4 \times 2} - 3\sqrt{25 \times 2} + 2\sqrt{36 \times 2} =$

$= 10\sqrt{2} - 15\sqrt{2} + 12\sqrt{2} =$

$= 7\sqrt{2}$

(b) $7\sqrt{12} - 5\sqrt{27} + 6\sqrt{75} =$

$= 7\sqrt{4 \times 3} - 5\sqrt{9 \times 3} + 6\sqrt{25 \times 3} =$

$= 14\sqrt{3} - 15\sqrt{3} + 30\sqrt{3} =$

$= 29\sqrt{3}$

2.

[2 points]

Write in the form $a\sqrt[3]{2}$ or $a\sqrt[3]{3}$, where $a \in \mathbb{Z}$:

(a) $2\sqrt[3]{16} - 4\sqrt[3]{54} + 5\sqrt[3]{128}$

$= 2\sqrt[3]{8 \times 2} - 4\sqrt[3]{27 \times 2} + 5\sqrt[3]{64 \times 2} =$

$= 4\sqrt[3]{2} - 12\sqrt[3]{2} + 20\sqrt[3]{2} =$

$= 12\sqrt[3]{2}$

(b) $\sqrt[3]{24} - 2\sqrt{81} + 2\sqrt{375}$

$= \sqrt[3]{8 \times 3} - 2\sqrt[3]{27 \times 3} + 2\sqrt[3]{125 \times 3} =$

$= 2\sqrt[3]{3} - 6\sqrt[3]{3} + 10\sqrt[3]{3} =$

$= 6\sqrt[3]{3}$

3.

[3 points]

Rationalize the following fractions:

(a) $\frac{12}{\sqrt{3}} \times \frac{\sqrt{3}}{\sqrt{3}} = \frac{12\sqrt{3}}{3} = 4\sqrt{3}$

(b) $\frac{15}{2\sqrt{5}} \times \frac{\sqrt{5}}{\sqrt{5}} = \frac{15\sqrt{5}}{10} = \frac{3\sqrt{5}}{2}$

(c) $\frac{2}{\sqrt[3]{4}} \times \frac{\sqrt[3]{2}}{\sqrt[3]{2}} = \frac{2\sqrt[3]{2}}{2} = \sqrt[3]{2}$

4.

[3 points]

Rationalize the following fractions:

(a) $\frac{2}{3 - \sqrt{3}} \times \frac{3 + \sqrt{3}}{3 + \sqrt{3}} =$

$= \frac{2(3 + \sqrt{3})}{6} =$

$= \frac{3 + \sqrt{3}}{3}$

(b) $\frac{8}{4 + \sqrt{2}} \times \frac{4 - \sqrt{2}}{4 - \sqrt{2}} =$

$= \frac{8(4 - \sqrt{2})}{14} =$

$= \frac{16 - 4\sqrt{2}}{7}$

(c) $\frac{11}{3 - 2\sqrt{2}} \times \frac{3 + 2\sqrt{2}}{3 + 2\sqrt{2}} =$

$= \frac{11(3 + 2\sqrt{2})}{1} =$

$= 33 + 22\sqrt{2}$

1.10 Speed, distance and time

The following standard notation will be used in this section:

s displacement from a given origin,

d distance travelled,

v velocity,

$|v|$ speed,

a acceleration,

t time.

Note that the **displacement** indicates the distance of an object from a fixed origin. If an object starts at the origin moves 2 metres forward and then 2 metres backwards, then its final displacement is 0, as it is back at the origin. However the **distance travelled** by this object is 4 metres (and not 0).

Velocity is the rate of change of displacement. This means, in particular, that velocity can be negative (if the object moves backwards). In fact, if we consider motion which isn't restricted to one dimension (backwards and forwards), then velocity is a vector. **Speed** is the magnitude of velocity, so it is always a non-negative real number. If speed is 0, then the object is at rest. We have:

$$|v_{average}| = \frac{d}{t}$$

Acceleration is the rate of change of velocity. Note that when an object is moving in the positive direction, then negative acceleration indicates that the speed is decreasing. However if the object is moving in the negative direction (backward), then negative acceleration indicates that its speed is increasing.

Note that for a motion along a line velocity is the gradient (slope) of the displacement-time graph, while speed is the gradient (slope) of the distance-time. Acceleration is the gradient of the the velocity-time graph. Distance travelled is the area under the speed-time graph, while displacement is the area under the velocity-time graph.

Worked example 1.10.1

An object started its motion at 5:30 am and finished at 3:20 pm the same day. It travelled a distance of 120 kilometres. Find its average speed.

The travel took 9 hours and 50 minutes which is $9\frac{5}{6}$ hours, so:

$$|v_{average}| = \frac{120}{9\frac{5}{6}} \approx 12.2 \frac{km}{h}$$

Exercise 1.10.1 Find the average speed of objects for the given journeys:

(a)
START: 9:20 am,
FINISH: 1:45 pm (same day),
DISTANCE = 90 km.

(b)
START: 10:37 am,
FINISH: 2:51 pm (same day),
DISTANCE = 200 km.

(c)
START: 8:45 pm,
FINISH: 7:15 am (next day),
DISTANCE = 800 km.

(d)
START: 11:20,
FINISH: 13:10 (same day),
DISTANCE = 82 km.

(e)
START: 13:45,
FINISH: 17:51 (same day),
DISTANCE = 170 km.

(f)
START: 7:32,
FINISH: 17:15 (next day),
DISTANCE = 950 km.

(g)
START: 7:49 pm,
FINISH: 1:04 pm (next day),
DISTANCE = 1500 km.

(h)
START: 10:10 am,
FINISH: 11:25 pm (next day),
DISTANCE = 350 km.

(i)
START: 6:55 am (Monday),
FINISH: 3:25 pm (Friday),
DISTANCE = 2800 km.

(j)
START: 8:11,
FINISH: 14:02 (next day),
DISTANCE = 1620 km.

(k)
START: 14:10,
FINISH: 13:25 (next day),
DISTANCE = 140 km.

(l)
START: 13:55 (Tuesday),
FINISH: 15:10 pm (Saturday),
DISTANCE = 5330 km.

(m)
START: 6:55 am (Tuesday),
FINISH: 3:25 pm (Thursday),
DISTANCE = 250 km.

(n)
START: 6:55 am (Saturday),
FINISH: 3:25 pm (Friday),
DISTANCE = 6500 km.

(o)
START: 13:12 (Friday),
FINISH: 16:25 (Monday),
DISTANCE = 1300 km.

(p)
START: 6:55 (Sunday),
FINISH: 18:45 (Saturday),
DISTANCE = 170 km.

(q)
START: 6:55 am (25th of May),
FINISH: 3:25 pm (30th of May),
DISTANCE = 4200 km.

(r)
START: 13:12 (30th of June),
FINISH: 16:25 (3rd of July),
DISTANCE = 200 km.

(s)
START: 14:03:12 ,
FINISH: 14:04:17 (same day),
DISTANCE = 300 m.

(t)
START: 5:51:05,
FINISH: 6:01:02 (same day),
DISTANCE = 550 m.

(u)
START: 23:59:42 ,
FINISH: 00:01:12 (next day),
DISTANCE = 120 m.

Worked example 1.10.2

The following graph shows motion of an object:

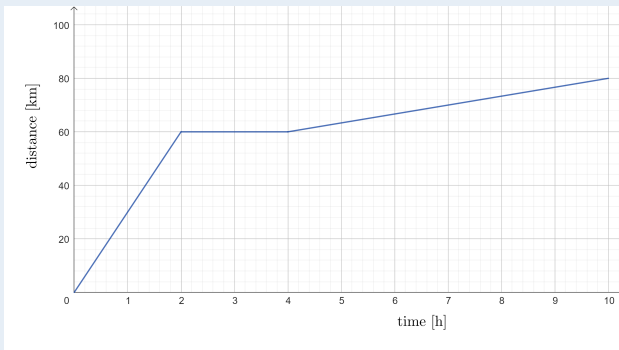

(a) Find the speed of the object when:

$$t = 1 \text{ h}$$

$$t = 3 \text{ h}$$

$$t = 8 \text{ h}$$

(b) Find the average speed of for the whole 10 hour journey.

(a) For the first 2 hours the distance is increasing at a constant rate, so the velocity is constant. The object travelled 60 km in 2 hours so the speed at $t = 1$ is:

$$|v(1)| = \frac{60}{2} = 30 \frac{\text{km}}{\text{h}}$$

For the next 2 hours the distance is not changing, so the object is at rest, which means that:

$$|v(3)| = 0$$

For the remaining 6 hours the distance is increasing at a constant rate. The object travelled 20 km in 6 hours, so:

$$|v(8)| = \frac{20}{6} = 3\frac{1}{3} \frac{\text{km}}{\text{h}}$$

(b) Over the whole journey the object travelled 80 kilometres in 10 hours, so we have:

$$|v_{\text{average}}| = \frac{80}{10} = 8 \frac{\text{km}}{\text{h}}$$

Exercise 1.10.2a

The following graph shows motion of an object:

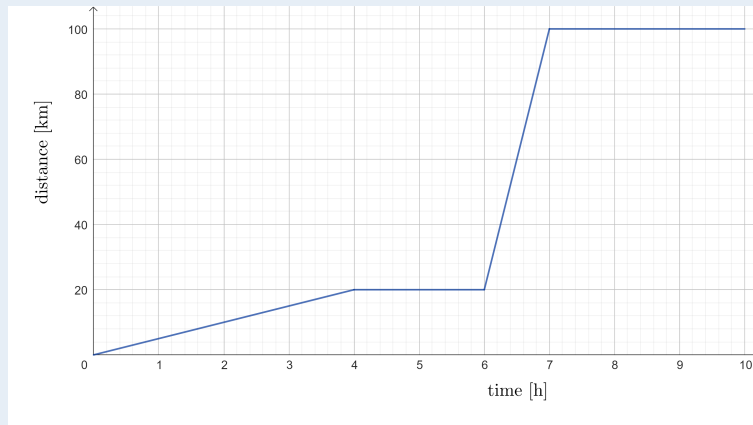

(a) Find the speed of the object when:

$$t = 1 \text{ h}$$

$$t = 5 \text{ h}$$

$$t = 400 \text{ min}$$

$$t = 8.5 \text{ h}$$

(b) Find the average speed of the object for the whole 10 hour journey.

Exercise 1.10.2b

The following graph shows motion of an object:

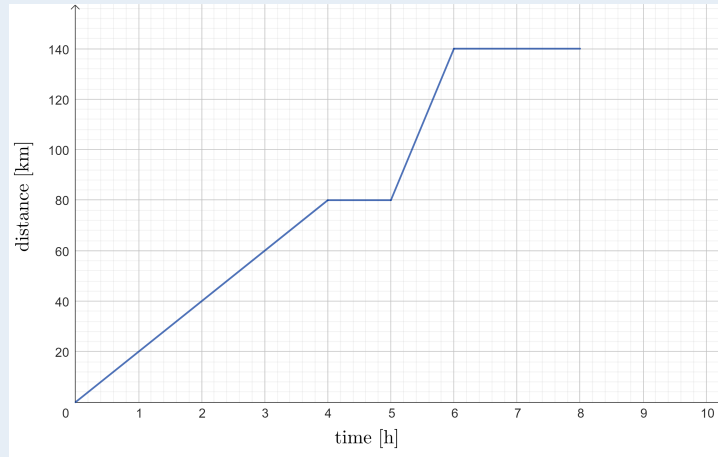

(a) Find the speed of the object when:

$$t = 3 \text{ h}$$

$$t = 250 \text{ min}$$

(b) Find the average speed of the object for the whole 8 hour journey.

(c) For how long was the object at rest?

(d) Find the average speed of the object while it was moving.

Exercise 1.10.2c

The following graph shows motion of an object:

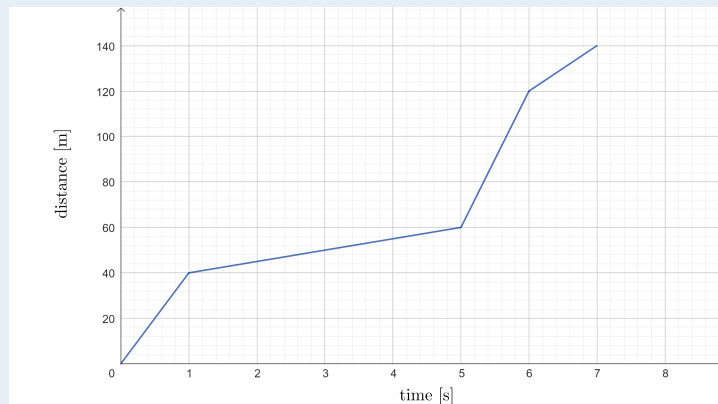

(a) Find the speed of the object when:

$$t = 0.5 \text{ s}$$

$$t = 3 \text{ s}$$

(b) Find the average speed of the object for the whole 7 second journey.

(c) During what times was the object moving the fastest?

Exercise 1.10.2d

The following graph shows motion of an object:

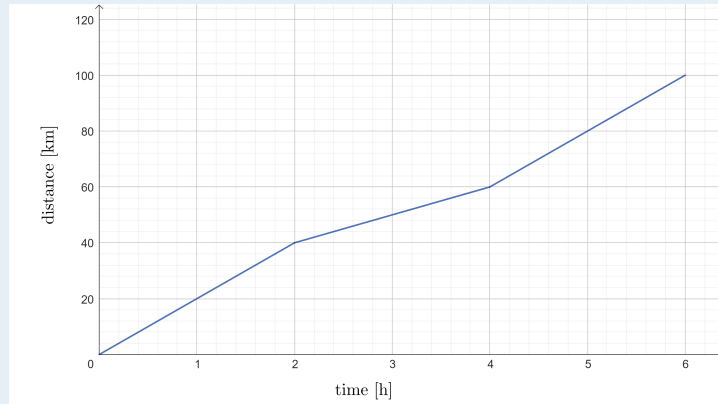

- Was the object moving with a constant speed throughout the journey?
- Describe the motion of the object.
- Find the average speed of the object for the whole 6 hour journey.

Exercise 1.10.2e

The following graph shows motion of an object:

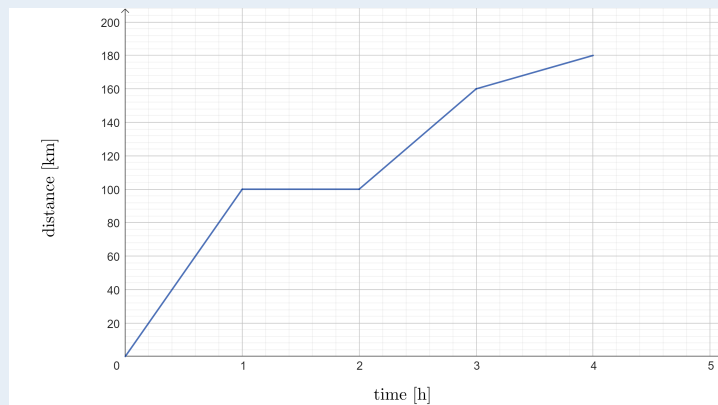

- At what times was the object moving the fastest?
- Describe the motion of the object.
- Find the average speed of the object for the whole 4 hour journey.
- Find the average speed of the object while it was moving.

Worked example 1.10.3

The following graph shows motion of an object along a straight path:

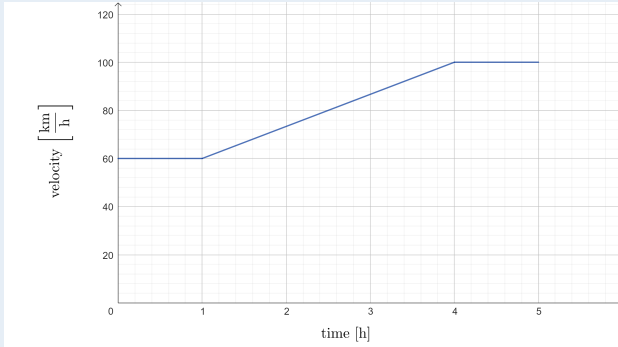

(a) Find the speed of the object when:

$$t = 0.5 \text{ h}$$

$$t = 4.5 \text{ h}$$

(b) Find the acceleration of the object when:

$$t = 0.5 \text{ h}$$

$$t = 2 \text{ h}$$

(b) Find the distance travelled by the object:

in the first 2 hours

during the whole journey

(a) We have:

$$|v(0.5)| = 60 \frac{\text{km}}{\text{h}} \quad |v(4.5)| = 100 \frac{\text{km}}{\text{h}}$$

(b) In the first hour the velocity is constant, so the acceleration is 0. Between $t = 1 \text{ h}$ and $t = 4 \text{ h}$ velocity increases at a constant rate, so acceleration is constant and we have:

$$a(2) = \frac{40}{3} = 13\frac{1}{3} \frac{\text{km}}{\text{h}^2}$$

(c) The distance is the area under the graph and we have:

$$d(2) = 60 \times 1 = 60 \text{ km}$$

Now we add the areas of two rectangles ($60 + 100$) and a trapezium:

$$d(5) = 160 + \frac{(100 + 60) \times 3}{2} = 400 \text{ km}$$

Exercise 1.10.3a

The following graph shows motion of an object along a straight path:

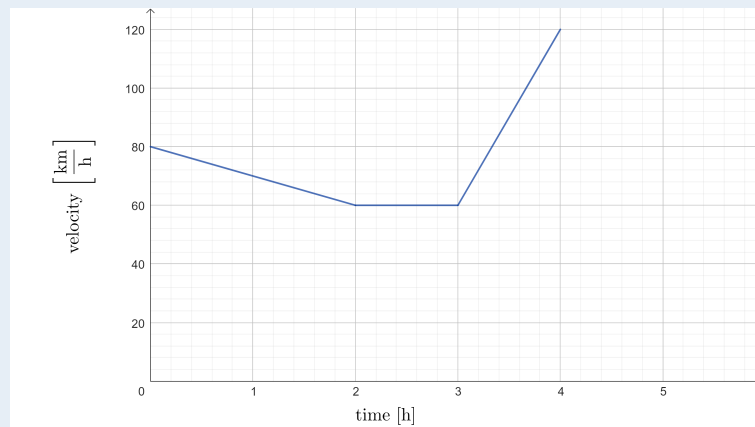

(a) Find the acceleration of the object when:

$$t = 1 \text{ h}$$

$$t = 2.5 \text{ h}$$

$$t = 200 \text{ min}$$

(b) Find the total distance travelled by the object.

Exercise 1.10.3b

The following graph shows motion of an object along a straight path:

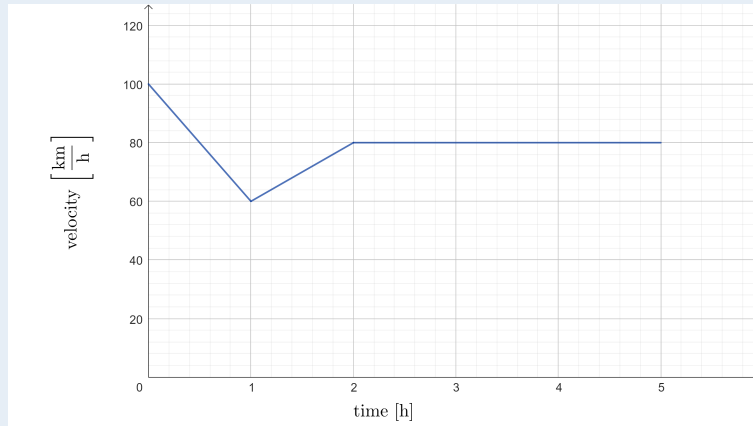

- Was the object at rest at any time during the journey?
- Describe the motion of the object.
- Find the total distance travelled by the object.

Exercise 1.10.3c

The following graph shows motion of an object along a straight path:

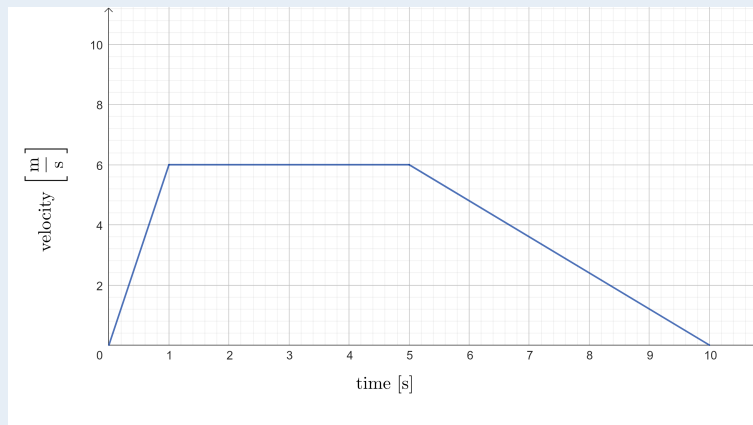

- Describe the motion of the object.
- Find the total distance travelled by the object.
- What was the acceleration of the object when $t = 0.5$ s?

Graphs of motion

1. Consider the following displacement-time graph of motion of an object:

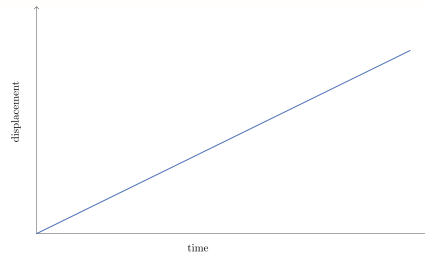

Describe the motion of the object and sketch the velocity-time and acceleration-time graphs for the motion of this object.

2. Consider the following velocity-time graph of motion of an object:

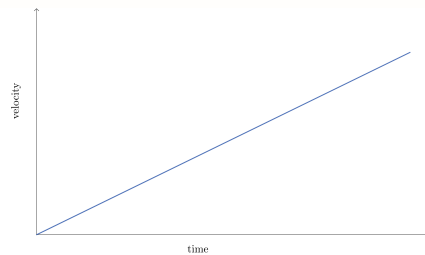

Describe the motion of the object and sketch the displacement-time (assuming the initial displacement is 0) and acceleration-time graphs for the motion of this object.

3. Consider the following velocity-time graph of motion of an object:

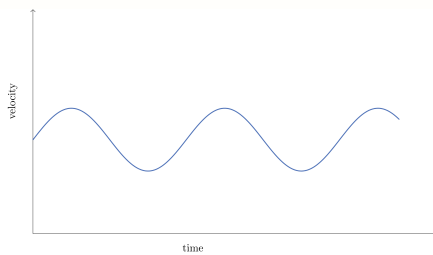

Describe the motion of the object and sketch the displacement-time (assuming the initial displacement is 0) and acceleration-time graphs for the motion of this object. What do you notice about the shapes of these graphs?

Note that 2.5h indicates 2 hours and 30 minutes. Ti-84 allows you to convert between decimal format and hour-minute-second format.

EXAMPLE 1

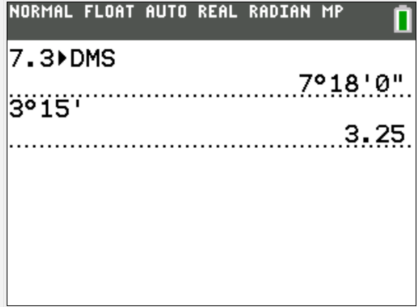
<p>(a) Change 7.3h into hours and minutes,</p> <p>(b) Change 3 hours and 15 minutes into hours in decimal.</p>	<p>INPUT</p> 	<p>OUTPUT</p> 
--	---	---

EXAMPLE 2

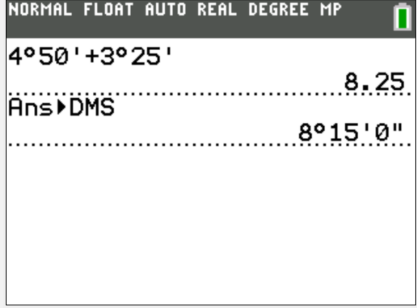
<p>Add 4 hours and 50 minutes to 3 hours and 25 minutes</p>	<p>INPUT</p> 	<p>OUTPUT</p> 
---	--	--

SHORT TEST

- 1.** [2 points]
An object started its motion at 7:30 pm and finished at 4:20 am the following day. It travelled a distance of 850 kilometres. Find its average speed.

- 2.** [4 points]
The following graph shows motion of an object:

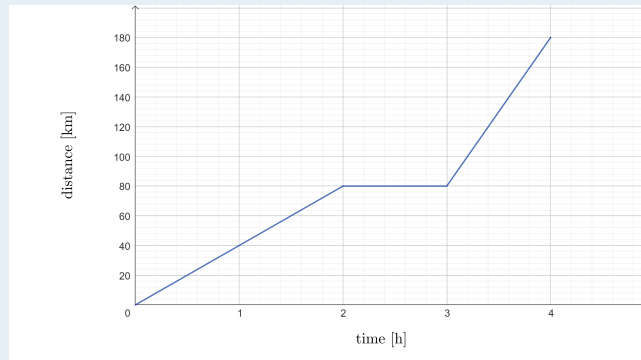

- (a) Find the speed of the object when $t = 1$ h.
 (b) At what times was the object moving the fastest?
 (c) Find the average speed of the object for the whole 4 hour journey.

- 3.** [4 points]
The following graph shows motion of an object along a straight path:

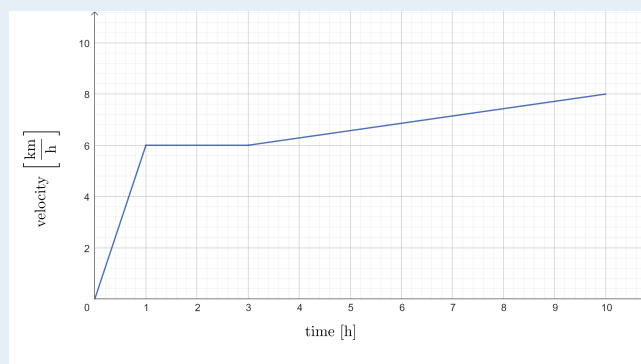

- (a) At what times was the object not accelerating?
 (b) Find the distance travelled by the object during the first hour.
 (c) Find the distance travelled by the object during the whole journey.

**SHORT TEST
SOLUTIONS**

1. [2 points]

An object started its motion at 7:30 pm and finished at 4:20 am the following day. It travelled a distance of 850 kilometres. Find its average speed.

Time of journey is 8 hours and 50 minutes, so $9\frac{5}{6}$ h. We then have:

$$|v_{average}| = \frac{850}{9\frac{5}{6}} \approx 86.4 \frac{km}{h}$$

2. [4 points]

The following graph shows motion of an object:

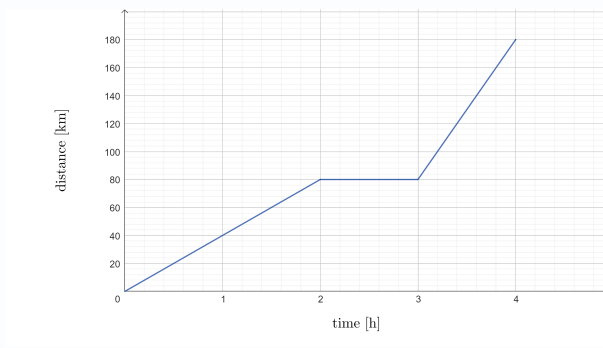

(a) Find the speed of the object when $t = 1$ h. $|v(1)| = \frac{80}{2} = 40 \frac{km}{h}$

(b) At what times was the object moving the fastest? **Between the 3rd and 4th hour of the journey.**

(c) Find the average speed of the object for the whole 4 hour journey. $|v_{average}| = \frac{180}{4} = 45 \frac{km}{h}$

3. [4 points]

The following graph shows motion of an object along a straight path:

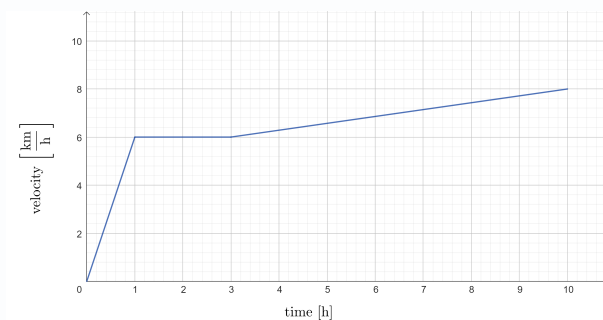

(a) At what times was the object not accelerating? **Between the 1st and 3rd hour of the journey.**

(b) Find the distance travelled by the object during the first hour. $d(1) = \frac{6 \times 1}{2} = 3 \text{ km}$

(c) Find the distance travelled by the object during the whole journey.

$$d(10) = 3 + 2 \times 6 + \frac{(6+8) \times 7}{2} = 64 \text{ km}$$

1.11 Money and finance

PROFIT & LOSS

The difference between income and cost is called profit (if positive) and loss (if negative).

Worked example 1.11.1

Tomasz buys apples, carrots and tomatoes from a farmer and re-sells them at a market. He buys apples for \$4.80, carrots \$6.50 and tomatoes \$5.10. He sells these at \$6.15, \$8.10 and \$6.90 respectively. Calculate Tomasz's profit for selling 10 kg of apples, 8 kg of carrots and 12 kg of tomatoes.

His profit per kg for each fruit and vegetable is:

$$\text{apple: } 6.15 - 4.80 = 1.35$$

$$\text{carrot: } 8.10 - 6.50 = 1.60$$

$$\text{tomato: } 6.90 - 5.10 = 1.80$$

So his total profit is:

$$10 \times 1.35 + 8 \times 1.60 + 12 \times 1.80 = \$47.90$$

Exercise 1.11.1a

Emily owns a flower shop and arranges bouquets. She buys flowers for \$1.50 per stem and charges \$20 for a bouquet of 10 stems. Calculate Emily's profit if she sells 50 bouquets.

Exercise 1.11.1b

Nancy specializes in importing coffee and tea blends. She buys Colombian coffee at \$6 per bag, green tea at \$4 per bag, and herbal tea at \$5 per bag. She sells them at \$9, \$6, and \$8 per bag, respectively. Calculate Nancy's profit if she sells 40 bags of Colombian coffee, 50 bags of green tea, and 30 bags of herbal tea.

Exercise 1.11.1c

Sandra runs a small grocery and buys corn, lettuce, and cucumbers from a local farmer. She spends \$2.75 on each kilogram of corn, \$2.00 per kilogram of lettuce, and \$3.30 per kilogram of cucumbers. She sells them at a price of \$3.60, \$2.80, and \$4.00 per kilogram, respectively. Calculate Sandra's profit if she sells 12 kg of corn, 15 kg of lettuce, and 8 kg of cucumbers.

Exercise 1.11.1d

Ella runs a flower stall. She buys roses at \$0.50 each, tulips at \$0.30 each, daisies at \$0.20 each, and orchids at \$1.00 each. She sells them at \$1.00, \$0.80, \$0.50, and \$2.00 each, respectively. Determine Ella's profit if she sells 100 roses, 150 tulips, 200 daisies, and 50 orchids.

NET & GROSS PAY

Gross pay is what employee earns before taking into account taxes and other deductions (like health insurance etc.). The so called take-home pay (the amount that the employee sees transferred to their account) is called the net pay.

Worked example 1.11.2

Tomasz works 40 hours a week at an hourly rate of \$11 per hour (basic pay) and an additional 5 hours of overtime for which he receive double the basic pay (double time). The deductions amount to 43% of his gross pay. Calculate what his weekly net pay is.

His gross pay is:

$$40 \times 11 + 5 \times 2 \times 11 = 550$$

The deductions amount to 43%, so his net pay is:

$$0.57 \times 550 = \$313.50$$

Exercise 1.11.2a

Jessica works 35 hours a week at an hourly rate of \$15. She also works 8 hours of overtime, where she earns time and a half (1.5 times the basic pay). Her deductions total 30% of her gross pay. Calculate Jessica's weekly net pay.

Exercise 1.11.2b

David works 45 hours a week with a basic hourly rate of \$12. For any additional hours beyond 40, he receives 1.5 times his basic pay. He also receives a weekly bonus of \$50. His total deductions amount to 28% of his gross pay. Determine David's weekly net pay.

Exercise 1.11.2c

Sarah works 50 hours a week at an hourly rate of \$10. For overtime hours beyond 40 hours, she earns double time (2 times the basic pay). Her total deductions are 25% of her gross pay. What is Sarah's weekly net pay?

Exercise 1.11.2d

David works 40 hours a week at an hourly rate of \$20. He also works 5 hours of overtime, where he earns double time (2 times the basic pay rate). His deductions amount to 35% of his gross pay. Calculate David's weekly net pay.

CONVERSIONS

Foreign currency exchange providers can earn money either by charging commission for each exchange or by using different exchange rates when selling and buying a given currency.

Worked example 1.11.3

Wanda uses a bank to exchange pounds into euros. The bank uses the exchange rate of $\text{£}1 = \text{€}1.18$, but the bank charges 5% commission on each transaction. Calculate how euro will Wanda receive by exchanging $\text{£}120$.

By exchanging $\text{£}120$ at a rate of $\text{£}1 = \text{€}1.18$ Wanda receives:

$$120 \times 1.18 = \text{€}141.6$$

But she needs to pay 5% commission, so she receives 95% of the above amount:

$$141.6 \times 0.95 = 134.52$$

She receives 134.52 euro.

Exercise 1.11.3a

Michael visits a currency exchange to convert U.S. dollars into Canadian dollars. The exchange rate is $\text{\$}1 = \text{C}\text{\$}1.25$. The currency exchange charges a 4% commission on each transaction. Calculate how many Canadian dollars Michael will receive if he exchanges $\text{\$}200$ US dollars.

Exercise 1.11.3b

Emily is traveling to Japan and wants to exchange her British pounds for Japanese yen. The bank offers an exchange rate of $\text{£}1 = \text{¥}150$. The bank charges a 3% commission on each transaction. Determine how many yen Emily will receive by exchanging $\text{£}250$.

Exercise 1.11.3c

Carlos is planning a trip to Australia and needs to convert euros into Australian dollars. The exchange rate is ($\text{€}1 = \text{A}\text{\$}1.60$). The currency exchange service charges a 6% commission on every transaction. Calculate how many Australian dollars Carlos will receive if he exchanges ($\text{€}300$).

Exercise 1.11.3d

Sophia is traveling to Europe and wants to convert her British pounds into euros. The exchange rate is $\text{£}1 = \text{€}1.15$. The currency exchange charges a 3% commission on each transaction. Calculate how many euros Sophia will receive if she exchanges $\text{£}300$.

Worked example 1.11.4

Maria goes on vacation to USA and takes 1000 PLN with her. She exchanges her money into USD and then spends 200 USD on her vacation and exchanges the rest back to PLN. She uses a bank that sells USD at a rate of $1 \text{ USD} = 3.92 \text{ PLN}$ and buys USD at a rate of $1 \text{ USD} = 3.79 \text{ PLN}$ (no commission). Calculate how much money (in PLN) Maria brings back from her vacation.

First the bank sell Maria USD at a rate of $1 \text{ USD} = 3.92 \text{ PLN}$, so she buys:

$$\frac{1000}{3.92} \approx 255.10 \text{ USD}$$

She then spends 200, so she brings back 55.10 USD. Now the bank buys these from her at a rate of $1 \text{ USD} = 3.79 \text{ PLN}$, so she brings back a total of:

$$55.10 \times 3.79 \approx 208.83 \text{ PLN}$$

Note that Maria (and the bank) uses different exchange rates when buying and selling USD.

Exercise 1.11.4a

John has 1500 AUD and travels to Europe. He exchanges his Australian dollars for euros. The bank sells euros at a rate of $1 \text{ EUR} = 1.60 \text{ AUD}$ and buys euros at a rate of $1 \text{ EUR} = 1.52 \text{ AUD}$ (no commission). John spends 500 EUR in Europe and exchanges the remaining euros back to Australian dollars. Calculate how much money (in AUD) John brings back.

Exercise 1.11.4b

Emily travels from Canada to Japan with 2000 CAD. She exchanges her Canadian dollars into Japanese yen at a rate of $1 \text{ JPY} = 0.0115 \text{ CAD}$, and the bank buys Japanese yen at a rate of $1 \text{ JPY} = 0.011 \text{ CAD}$ (no commission). After spending 60 000 JPY on her trip, she converts the remaining yen back to Canadian dollars. Calculate how much money (in CAD) Emily brings back.

Exercise 1.11.4c

Sophie goes to the USA with 800 EUR. She exchanges her euros for US dollars. The bank sells USD at a rate of $1 \text{ USD} = 0.85 \text{ EUR}$ and buys USD at a rate of $1 \text{ USD} = 0.80 \text{ EUR}$ (no commission). After spending 300 USD, Sophie exchanges the remaining USD back to euros. How much money (in EUR) does she bring back?

Exercise 1.11.4d

Alex travels to Japan with 1,000 GBP. He wants to exchange his pounds for Japanese yen. The bank sells JPY at a rate of $1 \text{ GBP} = 150 \text{ JPY}$ and buys JPY at a rate of $1 \text{ GBP} = 155 \text{ JPY}$ (no commission). After spending 30,000 JPY, Alex exchanges the remaining yen back to GBP. How much money (in GBP) does he bring back?

Inflation

1. If you have \$1000 and an item costs \$50, how many items can you afford to buy?
2. The price of this item increases by 4% each year. How many items will you be able to afford with \$1000 in 3 years time?

Inflation is the measure of the increase of price of goods in a given economy. As the price of goods increases, the value of money decrease, as you can afford to buy fewer goods.

The nominal value of \$1000 will always be \$1000. However the real value of \$1000 changes depending on how much can be purchased with this money. If the prices of goods increase, the value of money decreases. If the prices of goods increase twofold (inflation of 100%, then the real value of \$1000 becomes \$500 as you can afford half of what you could before the increase. In other words the real value of money is its nominal value adjusted for the change in the price of goods.

3. If the inflation averages 4% per year, what is the real value of \$1000 in 3 years time?
4. Compare the real value of \$1000 after two years in case where the inflation was 4% each year to the case where it was 5% in the first year and 3% in the second year.
5. If you invest money into savings account that pays 5% interest rate compounded yearly, while the inflation is 6% per year, would you expect the real value of the investment to be ever greater than its nominal value?
6. Calculate the real value of the investment from part 5. after 3 years.
7. Calculate the real value after 4 years of the investment of \$50000 into an account that pays %7 annual interest compounded yearly, if the average rate of inflation is %6 each year.

SHORT TEST

1. [2 points]

Oliver runs a bakery and specializes in selling pastries. He buys croissants at \$1.50 each, muffins at \$2 each, and scones at \$1.75 each. He sells these items for \$3, \$3.50, and \$3 each, respectively. Calculate Oliver's profit if he sells 100 croissants, 80 muffins, and 120 scones.

2. [2 points]

Eva works 45 hours a week at an hourly rate of \$18. She works 10 hours of overtime beyond her regular 35-hour schedule, where she earns time and a half (1.5 times the basic pay rate). Her total deductions are 28% of her gross pay. Calculate Eva's weekly net pay.

3. [2 points]

James is planning a trip to Japan and wants to convert his Canadian dollars into Japanese yen. The exchange rate is C\$1 = ¥85. The currency exchange charges a 2% commission on each transaction. Calculate how many yen James will receive if he exchanges C\$500.

4. [4 points]

Liam travels to Australia with 1000 GBP. He exchanges his pounds for Australian dollars. The currency exchange sells AUD at a rate of 1 AUD = 0.60 GBP and buys AUD at a rate of 1 AUD = 0.55 GBP (no commission). After spending 400 AUD on his trip, Liam exchanges the remaining AUD back to GBP. How much money (in GBP) does Liam bring back?

**SHORT TEST
SOLUTIONS**

1. [2 points]
Oliver runs a bakery and specializes in selling pastries. He buys croissants at \$1.50 each, muffins at \$2 each, and scones at \$1.75 each. He sells these items for \$3, \$3.50, and \$3 each, respectively. Calculate Oliver's profit if he sells 100 croissants, 80 muffins, and 120 scones.

Her profit is:

$$100 \times (3 - 1.50) + 80 \times (3.50 - 2) + 120 \times (3 - 1.75) = \$420$$

2. [2 points]
Eva works 45 hours a week at an hourly rate of \$18. She works 10 hours of overtime beyond her regular 35-hour schedule, where she earns time and a half (1.5 times the basic pay rate). Her total deductions are 28% of her gross pay. Calculate Eva's weekly net pay.

Her weekly net pay is:

$$0.72 \times (35 \times 18 + 10 \times 1.5 \times 18) = \$648$$

3. [2 points]
James is planning a trip to Japan and wants to convert his Canadian dollars into Japanese yen. The exchange rate is C\$1 = ¥85. The currency exchange charges a 2% commission on each transaction. Calculate how many yen James will receive if he exchanges C\$500.

James receives:

$$0.98 \times 500 \times 85 = ¥41650$$

4. [4 points]
Liam travels to Australia with 1000 GBP. He exchanges his pounds for Australian dollars. The currency exchange sells AUD at a rate of 1 AUD = 0.60 GBP and buys AUD at a rate of 1 AUD = 0.55 GBP (no commission). After spending 400 AUD on his trip, Liam exchanges the remaining AUD back to GBP. How much money (in GBP) does Liam bring back?

Liam takes to Australia:

$$\frac{1000}{0.60} = 1666.67 \text{ AUD}$$

He spends 400, so he has 1266.67 AUD left. He exchanges it back to GBP:

$$1266.67 \times 0.55 = 696.67 \text{ GBP}$$

1.12 Set notation and Venn diagrams

A set is a collection of items. In most cases these items will be numbers (in which case one can refer to the set as a number set), but they do not have to be. We use curly brackets $\{\}$ in order to list the elements of a set and we usually use capital letters to denote sets. Consider a set A such that $A = \{1, 2\}$. This set consists of two elements, this can be written as $n(A) = 2$ (the number of elements of A equals 2). 1 is **an element of** A , which can be denoted as $1 \in A$. Similarly $2 \in A$.

Consider a different set $B = \{A, 3\}$. B consists of the set A and the number 3. Note that $n(B) = 2$ and $A \in B$ and $3 \in B$, but $1 \notin B$.

Consider yet another set $C = \{1, 2, 3\}$. We have $n(C) = 3$. We also have $1 \in C$ and $2 \in C$, but $A \notin C$. A is not an element of C , but every element of A is also an element of C , in such cases we say that A is a **subset** of C and denote this as $A \subseteq C$. In fact A is a **proper subset** of C (there are elements of C that are not in A), this can be written as $A \subsetneq C$. Note that if $C \subsetneq A$, then also $C \subseteq A$, that is a proper subset is a subset. You may find the distinction between subset and proper subset analogous to the distinction between \leq and $<$.

Worked example 1.12.1

Consider the following sets:

$$A = \{1, 2, 3, 4\},$$

$$B = \{1, 2\},$$

$$C = \{3, 4, 5\}.$$

Decide if the following are true or false:

(a) $4 \in A$,

(b) $4 \in B$,

(c) $B \in A$,

(d) $B \subseteq A$,

(e) $C \subseteq A$,

(f) $n(C) = 5$.

(a) True, 4 is an element of A .

(b) False, 4 is not an element of B .

(c) False, B is not an element of A .

(d) True, B is a subset of A , because every element of B is also in A . In fact we also have that $B \subsetneq A$.

(e) False, C is not a subset of A . Not every element of C is in A (5 is in C , but not in A).

(f) False, $n(C) = 3$ i.e. C has three elements.

A set with no elements is called the **empty set** and is denoted with \emptyset . Of course we have $n(\emptyset) = 0$. Note that an empty set is a subset of every set, that is $\emptyset \subseteq A$ for any set A .

Exercise 1.12.1a

Let $A = \{1, 2, 3, 4, 5\}$, $B = \{3, 4, 5, 6\}$ and $C = \{1, 3, 5\}$. Decide if the following statements are true or false:

- | | | |
|-----------------------------|------------------------------|-----------------------|
| (a) $1 \in A$ | (b) $1 \in B$ | (c) $1 \in C$ |
| (d) $B \subseteq A$ | (e) $C \subseteq A$ | (f) $A \subseteq A$ |
| (g) $B \subsetneq A$ | (h) $C \subsetneq A$ | (i) $A \subsetneq A$ |
| (j) $n(A) = 5$ | (k) $n(B) = 6$ | (l) $n(C) = 5$ |
| (m) $\emptyset \subseteq A$ | (n) $\emptyset \subsetneq A$ | (o) $\emptyset \in A$ |

Exercise 1.12.1b

Let $X = \{1\}$, $Y = \{1, 2\}$ and $Z = \{1, X\}$. Decide if the following statements are true or false:

- | | | |
|---------------------|---------------------|---------------------|
| (a) $1 \in X$ | (b) $1 \in Y$ | (c) $1 \in Z$ |
| (d) $X \in Y$ | (e) $X \in Z$ | (f) $Y \in Z$ |
| (g) $X \subseteq Y$ | (h) $X \subseteq Z$ | (i) $Y \subseteq Z$ |
| (j) $n(X) = 1$ | (k) $n(Y) = 2$ | (l) $n(Z) = 3$ |

Instead of listing all elements of a set we may use the **set builder notation** to specify the conditions that the elements of the set must meet. The notation is as follows:

$$A = \{\text{variable} \mid \text{condition}\}$$

For example, consider $A = \{x \mid x \in \mathbb{N} \text{ and } x < 3\}$. A consists of natural number that are smaller than 3, so $A = \{0, 1, 2, 3\}$.

Exercise 1.12.2

List all elements of the following sets:

- | | |
|---|---|
| (a) $\{x \mid x \in \mathbb{N} \text{ and } 4 < x < 8\}$ | (b) $\{x \mid x^2 = 9\}$ |
| (c) $\{x \mid x \in \mathbb{Z} \text{ and } -2 < x \leq 4\}$ | (d) $\{x \mid x \in \mathbb{Q} \text{ and } x^2 = 2\}$ |
| (e) $\{x \mid x \text{ is even and } 1 \leq x \leq 9\}$ | (f) $\{x \mid x^2 = 16 \text{ and } x \notin \mathbb{N}\}$ |
| (g) $\{x \mid x \in \mathbb{N} \text{ and } x \text{ is a factor of } 12\}$ | (h) $\{x \mid x < 21 \text{ and } x \text{ is a positive multiple of } 5\}$ |

OPERATIONS ON SETS

The set of all objects that are considered in a given question or context is called the **universe** or the **universal set** and denoted with the letter U (some textbooks use Ω for the universal set).

We define the following operations on sets A and B (both being subsets of U):

\cup **union** $A \cup B = \{x \mid x \in A \text{ or } x \in B\}$. So a union of sets A and B is the set of all elements that are in A or in B (note that this includes elements that are in both A and B).

\cap **intersection** $A \cap B = \{x \mid x \in A \text{ and } x \in B\}$. An intersection of sets A and B is the set of all elements that are both in A and in B .

$-$ **difference** $A - B = \{x \mid x \in A \text{ but } x \notin B\}$. A difference of sets A minus B is the set of all elements that are in A but are not in B . Note that $A - B$ is of course not the same as $B - A$. Note also that some textbooks use the notation $A \setminus B$ for $A - B$.

c **complement** $A^c = \{x \mid x \notin A\}$. A complement of a set A is the set of all elements that are not in A . Some textbooks use the notation A' to denote A^c .

Note that we have:

$$A \cup \emptyset = A$$

$$A \cap \emptyset = \emptyset$$

$$A \cup U = U$$

$$A \cap U = A$$

$$A^c = U - A$$

$$A - B = A \cap B^c$$

$$(A \cup B)^c = A^c \cap B^c$$

$$(A \cap B)^c = A^c \cup B^c$$

The last two identities are known as **de Morgan's laws**.

Worked example 1.12.3

Let the universal set be:
 $U = \{x \mid x \in \mathbb{Z} \text{ and } 0 < x \leq 10\}$
 and let:

$$A = \{1, 2, 3, 4\}$$

$$B = \{x \mid x \text{ is prime}\}$$

$$C = \{x \mid x \text{ is even}\}$$

Find:

(a) $A \cup B$

(b) $A \cap C$

(c) $B - C$

(d) B^c

(e) $(A \cup B) - C$

First of all we have:

$$B = \{2, 3, 5, 7\} \quad \text{and} \quad C = \{2, 4, 6, 8, 10\}$$

Now we have:

(a) $A \cup B = \{1, 2, 3, 4, 5, 7\}$,

(b) $A \cap C = \{2, 4\}$,

(c) $B - C = \{3, 5, 7\}$,

(d) $B^c = \{1, 4, 6, 8, 9, 10\}$,

(e) $(A \cup B) - C = \{1, 3, 4, 5, 7\}$.

Exercise 1.12.3a Let $U = \{x \mid x \in \mathbb{Z} \text{ and } 0 \leq x < 10\}$ and let:

$$X = \{1, 2, 3, 4\} \quad Y = \{y \mid y \text{ is even}\} \quad Z = \{z \mid z \text{ is a square number}\}$$

Find:

(a) $X \cup Y$

(b) $X \cup Z$

(c) $Y \cup Z$

(d) $X \cap Y$

(e) $X \cap Z$

(f) $Y \cap Z$

(g) $X - Y$

(h) $X - Z$

(i) $Y - Z$

(j) X^c

(k) Y^c

(l) Z^c

Exercise 1.12.3b Let $U = \{x \mid x \in \mathbb{Z} \text{ and } 11 \leq x < 20\}$ and let:

$$A = \{13, 15, 16, 17\} \quad B = \{b \mid b \text{ is prime}\} \quad C = \{c \mid c \text{ is a triangular number}\}$$

Find:

(a) $A \cup B$

(b) $A \cup C$

(c) $B \cup C$

(d) $A \cap B$

(e) $A \cap C$

(f) $B \cap C$

(g) $A - B$

(h) $A - C$

(i) $B - C$

(j) A^c

(k) $A \cap B \cap C$

(l) $(A \cup B \cup C)^c$

VENN DIAGRAMS

Sets can be represented graphically using Venn diagrams. Let $U = \{1, 2, 3, 4, 5\}$ and $A = \{1, 3, 5\}$. This can be represented using a Venn diagram as follows:

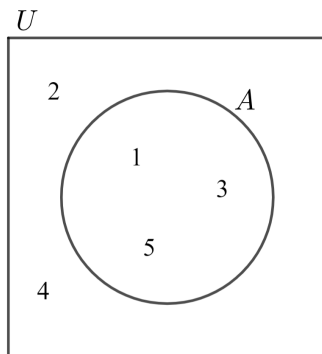

Consider another example with $U = \{x \mid x \in \mathbb{Z} \text{ and } 1 \leq x \leq 10\}$, $A = \{x \mid x \text{ is even}\}$ and $B = \{x \mid x \text{ is a multiple of } 3\}$. These sets can be represented as follows:

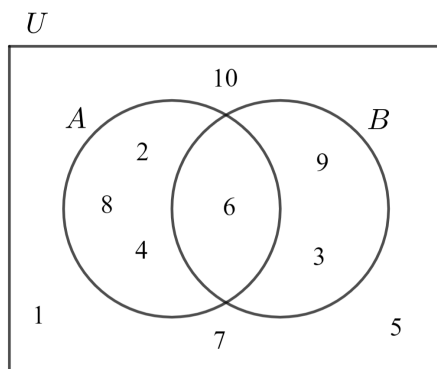

We may also have Venn diagrams with three sets. Consider the following. $U = \{x \mid x \in \mathbb{Z} \text{ and } 1 \leq x \leq 10\}$, $A = \{x \mid x \text{ is odd}\}$, $B = \{x \mid x < 6\}$ and $C = \{x \mid x \text{ is a multiple of } 3 \text{ or } 4\}$. We have the following Venn diagram for the above sets:

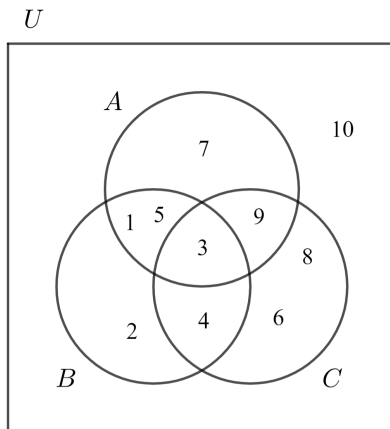

Consider another example with $U = \{1, 2, 3, 4, 5\}$, $A = \{1, 2, 3\}$ and $B = \{1, 2\}$. In this instance we have $B \subseteq A$, which can be illustrated as follows:

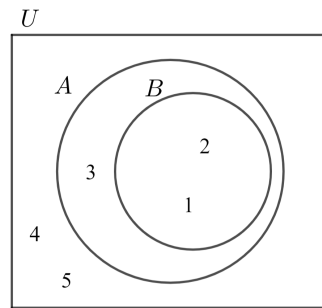

As a final example consider $U = \{1, 2, 3, 4, 5\}$, $A = \{1, 2\}$ and $B = \{4, 5\}$. Now we have $A \cap B = \emptyset$, which gives the following Venn diagram:

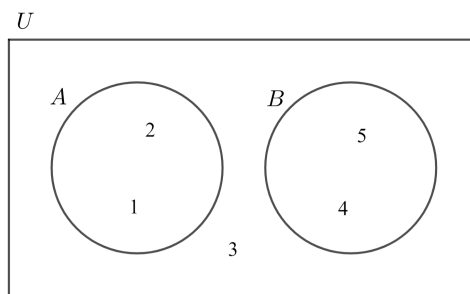

Exercise 1.12.4 Illustrate the following sets using Venn diagrams:

- (a) $U = \{1, 2, 3, 4, 5\}$, $A = \{1, 2, 3\}$ and $B = \{3, 4\}$
- (b) $U = \{1, 2, 3, 4, 5\}$, $A = \{x \mid x \text{ is prime}\}$ and $B = \{3, 4, 5\}$
- (c) $U = \{1, 2, 3, 4, 5, 6\}$, $A = \{x \mid x \text{ is even}\}$ and $B = \{3, 5\}$
- (d) $U = \{x \mid x \in \mathbb{Z} \text{ and } 1 \leq x \leq 10\}$, $A = \{1, 2, 3\}$ and $B = \{x \mid x > 5\}$
- (e) $U = \{x \mid x \in \mathbb{Z} \text{ and } 1 \leq x \leq 10\}$, $A = \{x \mid x \text{ is odd}\}$ and $B = \{x \mid x \text{ is a multiple of } 4\}$
- (f) $U = \{x \mid x \in \mathbb{Z} \text{ and } 11 \leq x \leq 20\}$, $A = \{x \mid x \text{ is prime}\}$ and $B = \{x \mid x \text{ is a multiple of } 3\}$
- (g) $U = \{x \mid x \in \mathbb{Z} \text{ and } 1 \leq x \leq 10\}$, $A = \{x \mid x \text{ is even}\}$, $B = \{x \mid x \text{ is a multiple of } 3\}$ and $C = \{1, 2, 3, 4, 5\}$
- (h) $U = \{x \mid x \in \mathbb{Z} \text{ and } 11 \leq x \leq 20\}$, $A = \{x \mid x \text{ is prime}\}$, $B = \{x \mid x \text{ is a multiple of } 5\}$ and $C = \{11, 12, 13, 14, 15\}$
- (i) $U = \{x \mid x \in \mathbb{Z} \text{ and } 0 \leq x \leq 10\}$, $A = \{x \mid x \text{ is a factor of } 12\}$, $B = \{x \mid x \text{ is prime}\}$ and $C = \{x \mid x \text{ is odd}\}$

Venn diagram can also be used to illustrate the operations on sets:

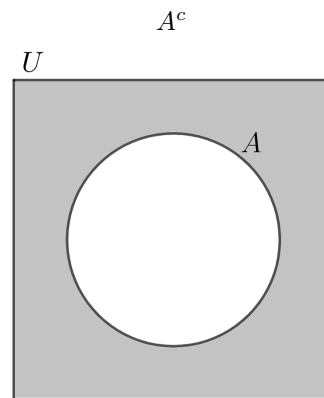
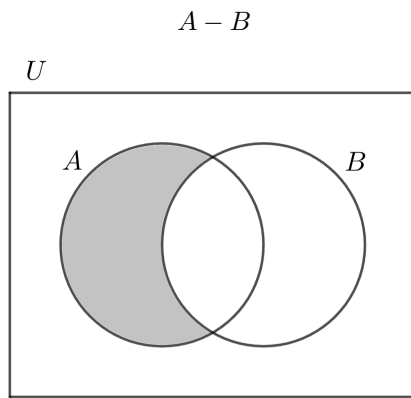
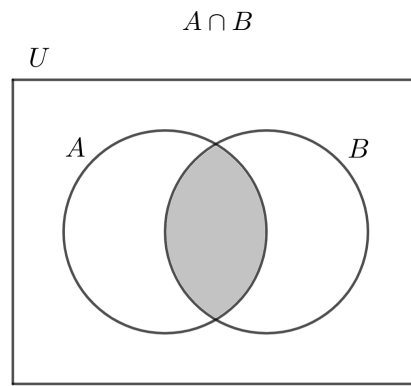
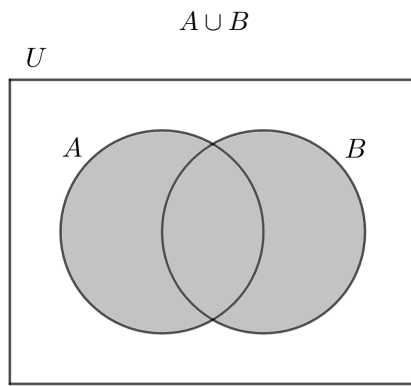

Similarly for three sets:

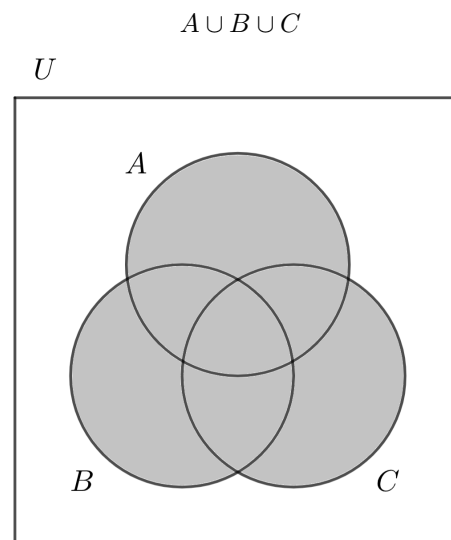
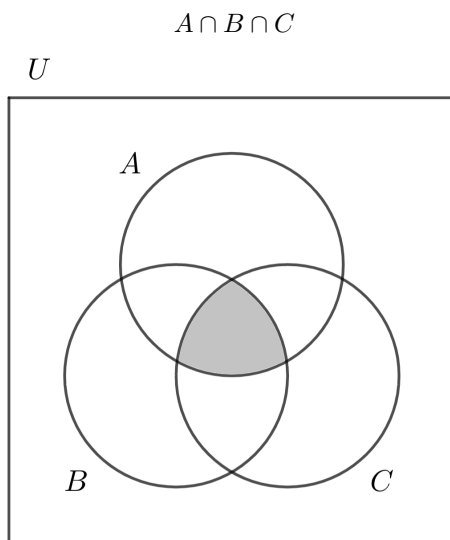

Worked example 1.12.5

Represent the following sets on a Venn diagram:

(a) $(A \cup B)^c$

(a) $(A \cup B)^c$ represents all elements that are not in $A \cup B$. We may start with $A \cup B$ and then highlight everything outside of this region:

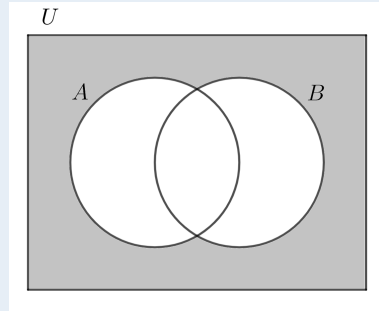

(b) $(A \cap B) \cup C$

(b) $A \cap B$ represents the intersection of A and B . Now we add everything that is in C to this intersection. The final set should be everything that is in both A and B and also everything that is in C :

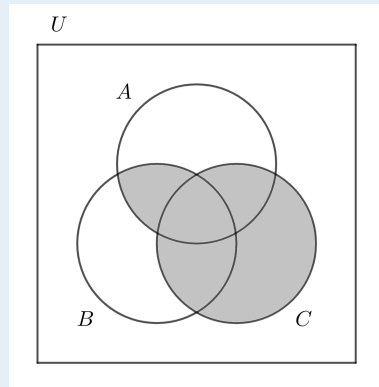

Exercise 1.12.5 Represent the following sets on a Venn diagram:

(a) $A^c \cap B$

(b) $B^c - A$

(c) $(A - B)^c$

(d) $(A \cup B) \cap C$

(e) $(A \cup C) - B$

(f) $(A \cap B \cap C)^c$

(g) $(A \cap C) - B$

(h) $B \cup (A - C)$

(i) $C \cap (B - A)$

(j) $(A \cap C) \cup (A \cap B)$

(k) $(A \cap B) - (A \cap C)$

(l) $(A \cap B) - (B \cup C)$

Venn diagrams can also be used to represent the number of elements in each step. Consider the following example:

$$n(U) = 24 \quad n(A) = 15 \quad n(B) = 12 \quad n(A \cap B) = 7$$

We can represent the above information on a Venn diagram by first including the information about the number of elements in $A \cap B$:

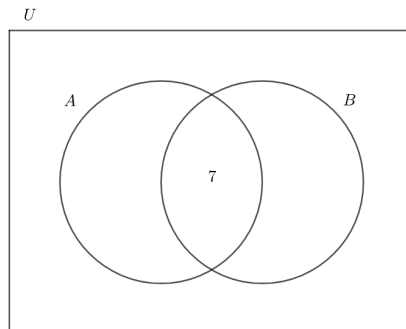

Note that the number 7 does not represent an element of $A \cap B$, but the total number of elements in $A \cap B$. We can now include the number of elements in the remaining regions of the Venn diagram. For example the number of elements in $A - B$ has to be 8, because the total number of elements in A is 15 and there are 7 elements in $A \cap B$ ($15 - 7 = 8$).

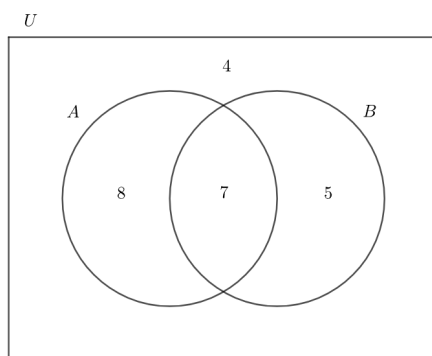

We get

$$n(A - B) = 8 \quad n(A \cap B) = 7 \quad n(B - A) = 5 \quad n((A \cup B)^c) = 4$$

When using a Venn diagram the following identities (that we use) become obvious visually:

$$n(A) = n(A \cap B) + n(A - B)$$

$$n(A) + n(A^c) = n(U) \quad \text{in particular} \quad n(A \cup B) + n((A \cup B)^c) = n(U)$$

Worked example 1.12.6a

Represent the following information on a Venn diagram:

$$n(U) = 13$$

$$n(A) = 9$$

$$n(B) = 4$$

$$n(A \cup B) = 11$$

Method 1

When we add the number of elements of A to the number of elements of B we get 13, which is 2 more than the number of elements of $A \cup B$. This excess comes from counting the number of elements of $A \cap B$ twice, so $n(A \cap B) = 2$.

Method 2

Let the number of elements of $A \cap B$ be x , then we get the following Venn diagram:

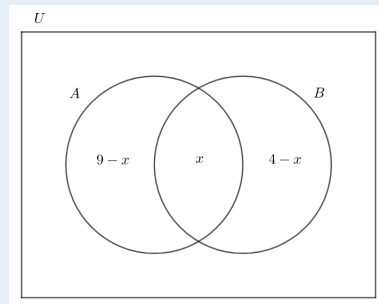

Now we can add up all the elements in $A \cup B$, which we know is 11:

$$9 - x + x + 4 - x = 11$$

which gives $x = 2$

Methods 1 & 2

Now we can produce the whole diagram by starting to include 2 in the part corresponding to $A \cap B$. We then have $n(A - B) = 9 - 2 = 7$, $n(B - A) = 4 - 2 = 2$ and finally $n((A \cup B)^c) = 13 - 11 = 2$

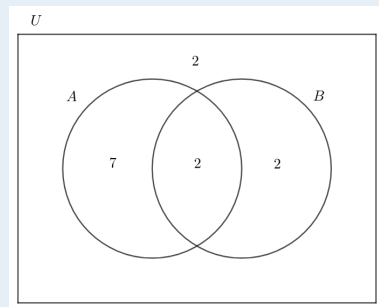

Exercise 1.12.6a Represent the following information on a Venn diagram:

$$(a) \quad n(U) = 20 \quad n(A) = 11 \quad n(B) = 7 \quad n(A \cap B) = 3$$

$$(b) \quad n(U) = 30 \quad n(A) = 21 \quad n(B) = 11 \quad n(A \cup B) = 27$$

$$(c) \quad n(U) = 25 \quad n(A - B) = 5 \quad n(B - A) = 8 \quad n(A \cup B) = 17$$

$$(d) \quad n(U) = 22 \quad n(A) = 14 \quad n(A - B) = 9 \quad n(A \cup B) = 16$$

$$(e) \quad n(U) = 50 \quad n(A) = 30 \quad n(B) = 25 \quad n(B - A) = 15$$

$$(f) \quad n(U) = 75 \quad n(A) = 60 \quad n(B) = 25 \quad n((A \cup B)^c) = 10$$

$$(g) \quad n(U) = 20 \quad n(A \cap B) = 6 \quad n(B - A) = 2n(A - B) \quad n((A \cup B)^c) = 2$$

$$(h) \quad n(U) = 15 \quad n(A) = 2n(B - A) \quad n(A - B) = n(B - A) + 2 \quad n((A \cup B)^c) = 6$$

Working with 3 sets is similar. If there is information that corresponds to a particular region of the Venn diagram, then it should be included and used to deduce further information. If however no (or no more) information can be directly put on the Venn diagram, then an auxiliary variable can be introduced as shown in the example below.

Worked example 1.12.6b

Represent the following information on a Venn diagram:

$$n(U) = 50$$

$$n(A) = 25$$

$$n(B) = 20$$

$$n(C) = 15$$

$$n(A \cap B) = 6$$

$$n(A \cap C) = 10$$

$$n(B \cap C) = 9$$

$$n(A \cup B \cup C) = 40$$

We are not given information about the number of elements of $A \cap B \cap C$, so we will set $n(A \cap B \cap C) = x$ and work backwards:

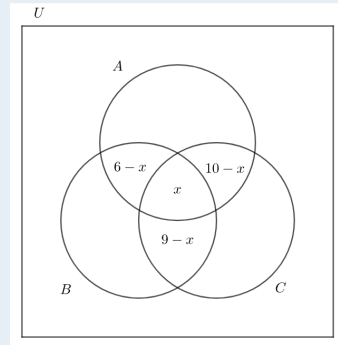

The number of elements of A is 25. By adding the regions in A filled so far we have $16 - x$, which means the remaining region must have $9 + x$ elements: $25 - (16 - x) = 9 + x$. Similarly we can fill in the remaining regions:

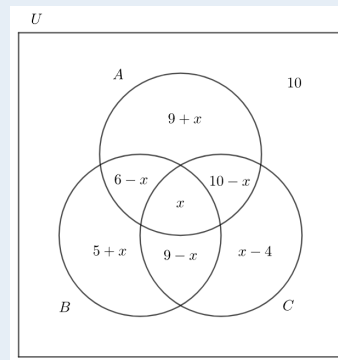

Now we can add up the number of elements of the region that constitute $A \cup B \cup C$. We know that they should add up to 40:

$$25 + (5 + x) + (9 - x) + (x - 4) = 40$$

This gives $x = 5$. So the Venn diagram becomes:

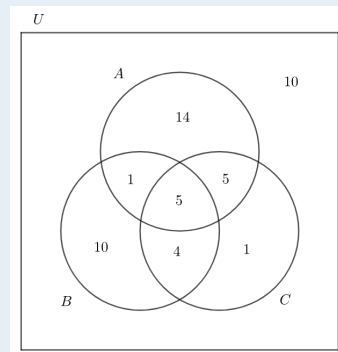

Exercise 1.12.6b

Represent the following information on a Venn diagram:

(a)

$$\begin{aligned}n(U) &= 35 \\n(A) &= 12 \\n(B) &= 19 \\n(C) &= 15 \\n(A \cap B) &= 6 \\n(A \cap C) &= 3 \\n(B \cap C) &= 4 \\n(A \cap B \cap C) &= 1\end{aligned}$$

(b)

$$\begin{aligned}n(U) &= 26 \\n(A) &= 18 \\n(B) &= 10 \\n(C) &= 12 \\n(A \cap B) &= 7 \\n(A \cap C) &= 5 \\n(B \cap C) &= 5 \\n(A \cap B \cap C) &= 2\end{aligned}$$

(c)

$$\begin{aligned}n(U) &= 22 \\n(A) &= 13 \\n(B) &= 14 \\n(C) &= 14 \\n(A \cap B) &= 12 \\n(A \cap C) &= 8 \\n(B \cap C) &= 9 \\n(A \cap B \cap C) &= 8\end{aligned}$$

(d)

$$\begin{aligned}n(U) &= 27 \\n(A) &= 16 \\n(B) &= 10 \\n(C) &= 8 \\n(A \cap B) &= 5 \\n(A \cap C) &= 4 \\n(B \cap C) &= 3 \\n(A \cup B \cup C) &= 25\end{aligned}$$

(e)

$$\begin{aligned}n(U) &= 30 \\n(A) &= 17 \\n(B) &= 13 \\n(C) &= 9 \\n(A \cap B) &= 8 \\n(A \cap C) &= 6 \\n(B \cap C) &= 6 \\n(A \cup B \cup C) &= 24\end{aligned}$$

(f)

$$\begin{aligned}n(U) &= 50 \\n(A) &= 14 \\n(B) &= 23 \\n(C) &= 16 \\n(A \cap B) &= 9 \\n(A \cap C) &= 4 \\n(B \cap C) &= 1 \\n(A \cup B \cup C) &= 39\end{aligned}$$

(g)

$$\begin{aligned}n(U) &= 30 \\n(A) &= 22 \\n(B) &= 15 \\n(C) &= 13 \\n(A \cap B) &= 8 \\n(A \cap C) &= 3n(A \cap B \cap C) \\n(B \cap C) &= 6 \\n((A \cup B \cup C)^c) &= 0\end{aligned}$$

(h)

$$\begin{aligned}n(U) &= 60 \\n(A) &= 30 \\n(B) &= 25 \\n(C) &= 20 \\n(A \cap B) &= 4n(A \cap B \cap C) \\n(A \cap C) &= 12 \\n(B \cap C) &= 7 \\n((A \cup B \cup C)^c) &= 10\end{aligned}$$

(i)

$$\begin{aligned}n(U) &= 80 \\n(A) &= 35 \\n(B) &= 28 \\n(C) &= 18 \\n(A \cap B) &= 19 \\n(A \cap C) &= 7 \\n(B \cap C) &= 5n(A \cap B \cap C) \\n(A \cup B \cup C) &= 60\end{aligned}$$

(j)

$$\begin{aligned}n(U) &= 30 \\n(A) &= 19 \\n(B) &= 12 \\n(C) &= 12 \\n(A - B) &= 12 \\n(A - C) &= 11 \\n(B - C) &= 9 \\n(A \cap B \cap C) &= 1\end{aligned}$$

(k)

$$\begin{aligned}n(U) &= 40 \\n(A) &= 22 \\n(B) &= 15 \\n(C) &= 14 \\n(A - B) &= 13 \\n(A - C) &= 12 \\n(B - C) &= 10 \\n(A \cap B \cap C) &= 2\end{aligned}$$

(l)

$$\begin{aligned}n(U) &= 50 \\n(A) &= 24 \\n(B) &= 20 \\n(C) &= 18 \\n(A - B) &= 14 \\n(A - C) &= 15 \\n(C - B) &= 11 \\n(A \cap B \cap C) &= 3\end{aligned}$$

Venn diagrams can be used to solve word problems like the ones below. These are in essence identical problems to those in exercise 1.12.6, but the information about the number of elements of each set is given in a more elaborate way.

Exercise 1.12.7a In a group of 20 student, 12 chose Mathematics HL and 7 chose Physics HL. 5 students chose both of the mentioned subjects. Represent this information on a Venn diagram and find the number of students who did not choose any of the two subjects.

Exercise 1.12.7b 50 students were asked about their free time activities. 22 like playing computer games, 19 like watching Netflix. 15 do not like neither. Represent the information on a Venn diagram and find the number of students who like both playing computer games and watching Netflix.

Exercise 1.12.7c In a group of 25 students: 15 speak Spanish, 8 speak German, 7 speak French, 3 speak Spanish and German, 3 speak Spanish and French, 2 speak German and French and 1 person speaks all three languages. Represent this information on a Venn diagram and hence find the number of students in this group who do not speak any of the three languages.

Exercise 1.12.7d In a group of 31 students everyone chooses at least one of the three sports: football, basketball or volleyball. 14 students chose football, 14 chose basketball and 16 chose volleyball, 4 chose both football and basketball, 4 chose both football and volleyball and 8 chose both basketball and volleyball. Represent the above information on a Venn diagram and find the number of students who chose all 3 sports.

Exercise 1.12.7e In a group of 25 people were asked if they ate any of the following meals in the last 7 days: spaghetti, pizza or lasagne. 11 ate spaghetti, 10 ate pizza, 7 ate lasagne, 5 ate spaghetti and pizza, 2 ate spaghetti and lasagne and 4 ate pizza and lasagne. 7 people did not eat any of the mentioned meals. Represent the information on a Venn diagram and find the number of people who are exactly one of the mentioned meals.

Power sets

1. Consider the set with two elements $A = \{1, 2\}$. List all subsets of A . Remember to include \emptyset and A itself.
2. Now consider $B = \{1, 2, 3\}$. List all subsets of B .
3. How many subsets does \emptyset have?
4. How many subsets does a set with one element have?

A power set of a set A is a set consisting of all subsets of A and is denoted by $\mathbb{P}(A)$.

5. Explain why, for a finite set A , the number of elements of a power set of A is always greater than the number of elements of A .
6. Fill in the following table:

$n(A)$	$n(\mathbb{P}(A))$
0	
1	
2	
3	
4	

7. Consider a set A with x elements, conjecture and justify a formula for the number of elements of $\mathbb{P}(A)$.

SHORT TEST

1. [4 points]

Let $U = \{x \mid x \in \mathbb{Z} \text{ and } 1 \leq x \leq 10\}$ and let A be the set of prime numbers in U , $B = \{2, 3, 5\}$ and $C = \{x \mid x^2 > 30\}$.

(a) State if the following are true or false and justify your answer:

(i) $B \subseteq A$

(ii) $B \cap C = \emptyset$

(iii) $A \cap C = \emptyset$

(b) Write down all elements of A^c .

2. [2 points]

Represent the following on Venn diagrams.

(i) $A \cup B^c$

(ii) $(A \cap B) - C$

3. [2 points]

Let $n(U) = 18$, $n(A) = 10$, $n(B) = 7$ and $n((A \cup B)^c) = 5$. Represent this information on Venn diagram and find $n(A \cap B)$.

4. [4 points]

In a group of 25 students:

10 like physics,

12 like chemistry,

11 like biology,

2 like physics and chemistry,

3 like physics and biology,

7 like biology and chemistry,

4 students do not like any of the three mentioned subjects.

Represent the information on a Venn diagram and find the number of students who like all three subjects.

**SHORT TEST
SOLUTIONS**

1. [4 points]

Let $U = \{x \mid x \in \mathbb{Z} \text{ and } 1 \leq x \leq 10\}$ and let A be the set of prime numbers in U , $B = \{2, 3, 5\}$ and $C = \{x \mid x^2 > 30\}$. **Note that we have $A = \{2, 3, 5, 7\}$ and $C = \{6, 7, 8, 9, 10\}$**

(a) State if the following are true or false and justify your answer:

(i) $B \subseteq A$
(i) true

(ii) $B \cap C = \emptyset$
(ii) true

(iii) $A \cap C = \emptyset$
(iii) false, $7 \in A \cap C$

(b) Write down all elements of A^c .

$A^c = \{1, 4, 6, 8, 9, 10\}$

2. [2 points]

Represent the following on Venn diagrams.

(i) $A \cup B^c$

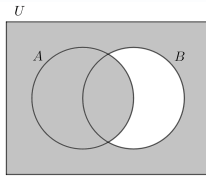

(ii) $(A \cap B) - C$

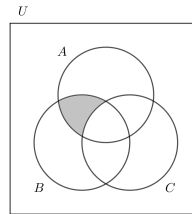

3. [2 points]

Let $n(U) = 18, n(A) = 10, n(B) = 7$ and $n((A \cup B)^c) = 5$. Represent this information on Venn diagram and find $n(A \cap B)$. $n(A \cap B) = 4$

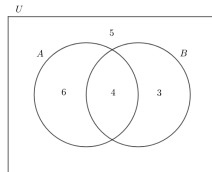

4. [4 points]

In a group of 25 students: 10 like physics, 12 like chemistry, 11 like biology, 2 like physics and chemistry, 3 like physics and biology, 7 like biology and chemistry, 4 students do not like any of the three mentioned subjects.

Represent the information on a Venn diagram and find the number of students who like all three subjects.

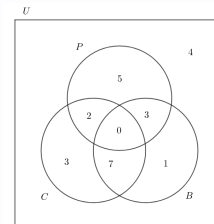
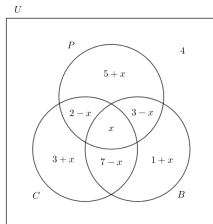

No student likes all three subjects.

1.13 End of unit test

TEST 1

- The test consists of two sections. In section A calculators are **not allowed**. GDC is required for section B.
- Unless otherwise stated in the question, all numerical answers should be given exactly or correct to three significant figures.
- The maximum mark for this test is [**36 + 36 marks**].
- Time allowed is **90 minutes**.
- Full marks are not necessarily awarded for a correct answer with no working. Answers must be supported by working and/or explanations. Where an answer is incorrect, some marks may be given for a correct method, provided this is shown by written working. You are therefore advised to **show all working**.

SECTION A

1.

[4 points]

Consider the following numbers:

$$a = \sqrt[3]{-64},$$

$$b = \frac{696412008}{8},$$

$c =$ reciprocal of 3,

$$d = 27^{-\frac{1}{3}}$$

Classify these numbers by placing them in appropriate regions of the diagram below.

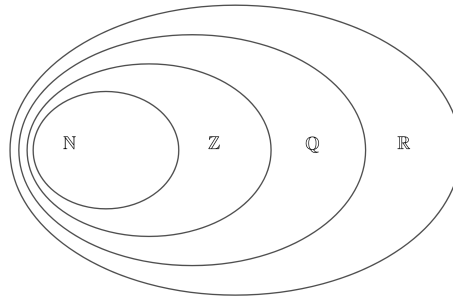

2.

[4 points]

(a) Write 120 as a product of prime factors and hence find the number of all factors of 120. [2]

(b) Find the highest common factor of 48 and 120. [2]

3.

[4 points]

(a) Write $0.\dot{3}\dot{6}$ as a proper fraction in simplified form.

[2]

(b) Write $\frac{13}{27}$ as a recurring decimal.

[2]

4.

[4 points]

A certain amount of money has been divided among 3 people in the ratio 2:3:4. If the person who received the most, received \$300 less than the other two people combined, calculate how much each person received.

5.

[3 points]

Round:

(a) 14589 to the nearest hundred,

[1]

(b) 22.7969 to 2 d.p.,

[1]

(c) 604.1455 to 3 s.f.

[1]

6.

[4 points]

Consider the following solid (diagram not to scale):

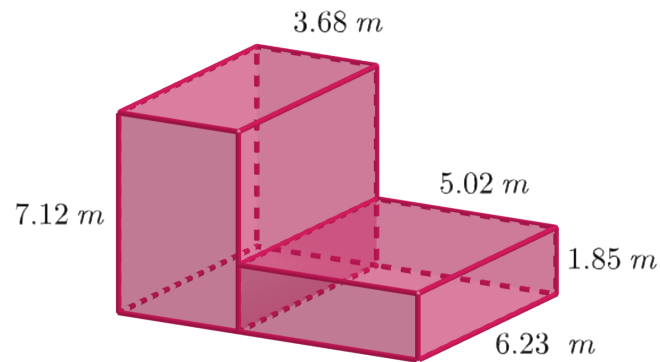

By rounding all lengths to 1 s.f. estimate the volume and the surface area of this solid.

7.

[4 points]

Consider the following rectangle (diagram not to scale):

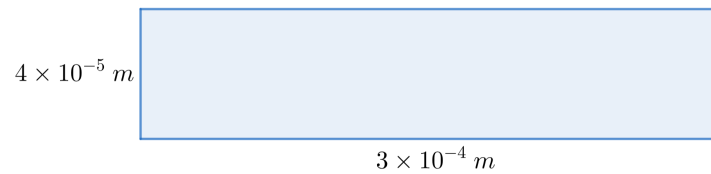

Find the perimeter and the area of this rectangle. Give your answers in standard form.

8.

[5 points]

Calculate and arrange in ascending order:

$$\frac{\frac{2}{3} - \frac{1}{4}}{\frac{5}{6} + \frac{1}{5}},$$

$$5.23 \times 10^{-1},$$

$$8^{-\frac{2}{3}},$$

$$\sqrt[3]{0.027},$$

$$0.4\% \text{ of } 50$$

9.

[4 points]

(a) Write as a power of 2:

[2]

$$\frac{16^4 \times (\sqrt{2})^6}{\left(\frac{1}{4}\right)^{-3} \times 8^{\frac{5}{3}}} =$$

(b) Simplify:

[2]

$$\frac{(4a^2b)^4 \times \left(\frac{b}{2a}\right)^5}{\left(\frac{1}{2}ab^{-2}\right)^3}$$

SECTION B

1. [4 points]

Maria invests her savings into an account that pays 8% annual interest rate compounded every 6 months.
[4 points]

(a) How much does she need to invest in order to have \$100000 in her account in 5 years? [2]

(b) If she invests \$40000, how long will it take for her money to double? [2]

2. [3 points]

The width of a rectangle has been decreased by 15%. By how much does the length need to be increased in order for the area to increase by 2%?

3.

[3 points]

Wanda exchanged 3 000 PLN in GDP at a rate 5.12PLN = 1GBP for her vacation in England. She spent 500 GBP while there and exchanged the remaining pounds into zlotys at a rate 5.04PLN = 1GBP. Calculate how many PLN she brings back from her vacation.

4.

[3 points]

The universal set U consists of all positive integers smaller than 10. Consider the following subsets of U :

$$A = \{1, 2, 6, 7\} \quad B = \{5, 6, 7\} \quad C = \{1, 2, 3, 4, 5\}$$

Write down: (a) $A \cap B$ (b) $A \cup C$ (c) C'

5.

[3 points]

Write the following expression in the form $a + b\sqrt{2}$, where $a, b \in \mathbb{Z}$:

$$3\sqrt{18} - \frac{8}{\sqrt{2}} + \frac{14}{3 - \sqrt{2}}$$

6.

[4 points]

Population of a certain town grows by 5% each year. The population of this town in 2024 is 42 000.

(a) Calculate the expected population in 2030. [2]

(b) In what year will the population exceed 100 000? [2]

7.

[5 points]

The following diagram shows the distance-time graph of a moving object.

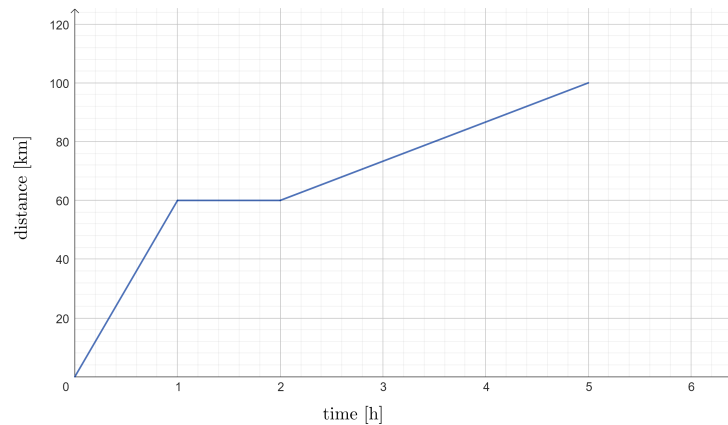

(a) Find the speed of the object at $t = 4$ h. [2]

(b) How long as the object at rest? [1]

(c) Find the average speed of the object for the whole 5 hour journey. [2]

8.

[4 points]

The electrical resistance of a wire is directly proportional to the length of the wire and inversely proportional to its cross-sectional area. If the resistance is 15 ohms when the length is 20 m and the cross-sectional area is 2 mm^2 , find the resistance when the length is 15 m and the cross-sectional area is 3 mm^2 .

9.

[2 points]

Calculate the value of the following expression. Give your answer in standard form rounded to 4 s.f.:

$$\frac{(3.541 \times 10^5) \times (2.511 \times 10^{-3})}{(8.745 \times 10^6) + (9.253 \times 10^5)} =$$

10.

[5 points]

A group of 30 people were asked about what pet they own. They had 4 options to choose from: dog (D), cat (C), bird (B) or none of the above. More than one option could be chosen. The results are as follows:

18 own a dog,
12 own a cat,
11 own a bird,
3 own a dog and a cat,
7 own a dog and a bird,
6 own a cat and a bird,
3 own none of the above pets.

Let x represent the number of people who own all three pets.

- (a) Represent the above information on a Venn diagram. [2]
- (b) Calculate the value of x . [2]
- (c) Find the number of people who own a dog or a cat but no bird. [1]